

Table of Contents

2020 GMC Technical bulletin #161 (Radio HVAC IPC blank out when operating a Snowplow)2

(2014 - 2019) GMC Technical bulletin #124k (Radio HVAC IPC blank out when operating a Snowplow)8

GMC technical bulletin #131b (Elevated Engine Coolant/Operating Temperatures when Snowplow mounted)30

GMC technical bulletin #116b (Snowplow Lamp activation)31



Subject: Intermittent Cluster, Radio and HVAC Display
Resets on Snow Plow Trucks

Models/Years 2020 – beyond Chevrolet Silverado 2500-3500 HD

Affected: 2020 - beyond GMC Sierra 2500-3500 HD
With Snow Plow Prep Package (RPO VYU)

Origination January 16, 2020

Date:

Revision TBD

Date:

ADVISORY:

Condition/Concern:

Some trucks equipped with option VYU [Snow Plow Prep] and a snow plow, may exhibit occurrences in which the Instrument Panel Cluster (IPC), Radio and HVAC displays may “blank out” or reset after changing the snow plow position. This condition is caused by a system voltage over-shoot phenomenon called ‘load dump’. When the large electrical draw of the plow pump motor is suddenly removed the field energy that is built up in the alternator causes a system voltage overshoot that momentarily moves above the normal design operating levels for the module displays. As a result, the displays will shut down or reset causing the momentary blank out condition. The modules are designed to do this and immediately recover. *No modules* should be replaced for this condition.

Repair/Recommendation:

Contact your local GM Dealer for an appointment to install **P/N is 84731643 (HD only) VYU Snow Plow Jumper harness** per the latest version of **GM Service Bulletin PIT5387G**. If your truck has RPO VYU and did not come with the harness parts they may be ordered by your dealer.

Note: This jumper harness and installation will be provided [one time] without charge. Installation charges will be waived only if the jumper is installed at your GM dealer.

General Motors Upfitter Integration

<http://www.gmupfitter.com>



Installation Instructions:

- 1) Locate and drill holes (9.0mm) for the mounting location of the mini electrical center per figure (TBD). Use the mounting bracket as a template for holes as shown in figure TBD. Be sure to use a drill suitable for high strength steel and a lubricating oil/fluid
- 2)

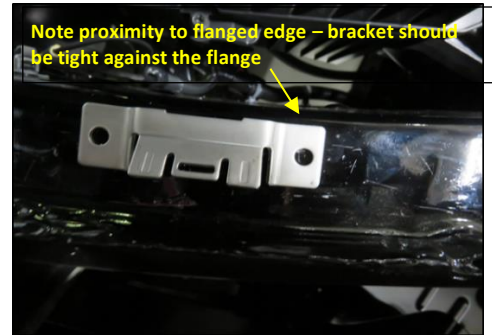
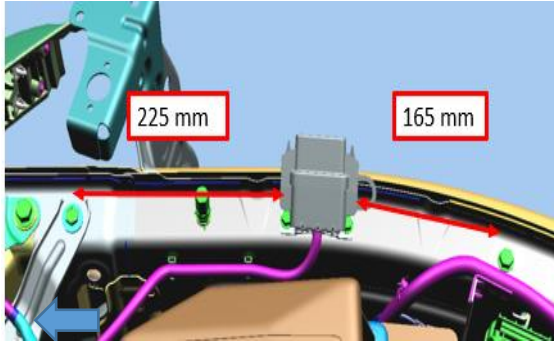

- 3) Once drilled holes are completed install the 2 riv-nuts included in the kit (see figure TBD) using GM Special Service Tool BO-42151-6MM-KIT or equivalent (shown in figure TBD) as follows:
 - a) Apply lubricant to bolt threads. Insert bolt (4) through washer (3) and anvil (2) into rivet nut (1) until finger tight.
 - b) Insert rivet nut assembly into hole in sheet metal.
 - c) Hold anvil (6) with 9/16" wrench and tighten bolt (5) with 10 mm wrench to crimp the rivet nut approximate 3 turns. *Do not over tighten.*
 - d) Remove bolt, washer and anvil.

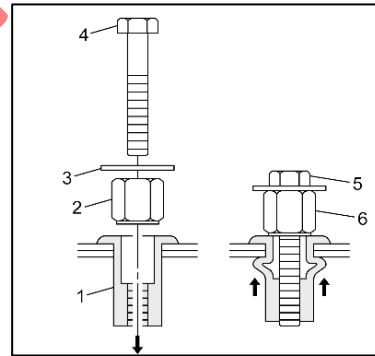

- 4) Remove Air Cleaner Outlet Duct (Figure TBD) per GM Service Information Link below.
[Air Cleaner Outlet Duct Replacement](#)





- 5) Using the supplied 6mm bolts, loosely install the bracket for the mini electrical center such that center retaining tab faces outboard from the flanged edge (refer to figure TBD).



- 6) After you have installed the bracket, attach the relay box to the bracket mount



- 7) Using 2 of the supplied combination tie strap/clip retainers, route and secure as shown in figure TBD.

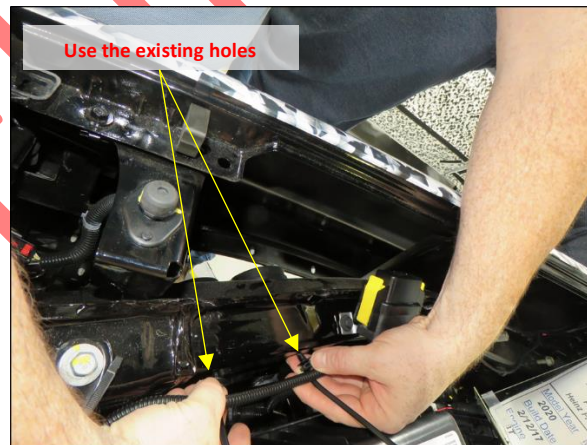



- 8) Continue routing and securing the wiring harness using the combination tie strap/clips provide. Secure to the center radiator support bracket as shown in figure TBD

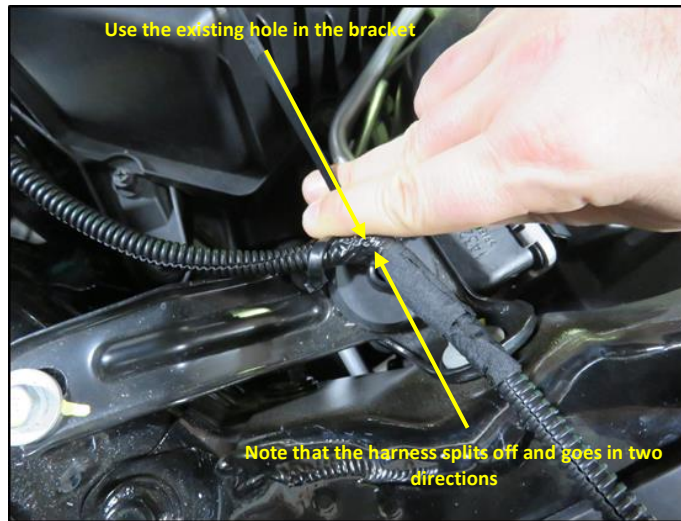

- 9) In figures TBD it is shown the harness splits off in 2 different directions. The large bundle will be routed across and secured using the tie strap/clips to the 6.5mm holes that are needed to be drilled into the cooling fan shroud as shown in figure TBD



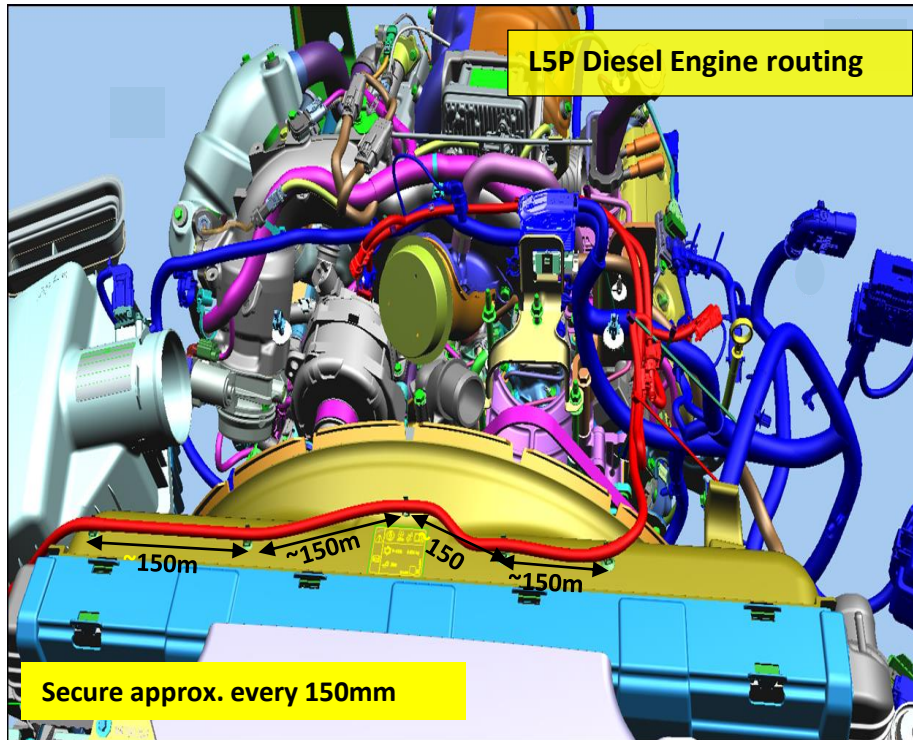

10)

11) The smaller bundle is routed beneath the air baffle

12) **Single generator systems:**

- a) Unplug the 2-way connector on the generator. (Figure 1)
- b) Identify the master generator connector [at the very tip of the harness when it is fully extended]. Insert it in the alternator.
- c) Take the original alternator connector and plug it into the mating jumper harness connector.
Note: In this case the second alternator connector will be unused and will remain capped and tied to the harness bundle.

13) **Dual generator systems:**

- a) Unplug the control connectors on both alternators.
- b) Identify the master alternator connector [at the very tip of the harness when it is fully extended]. Insert it in the 'master' alternator on the RH side of the engine.
- c) Identify the 'slave' alternator connector on the jumper harness and insert it in the LH 'slave' alternator. Insert the removed LH alternator connector into the [unwired] cap on the jumper harness.

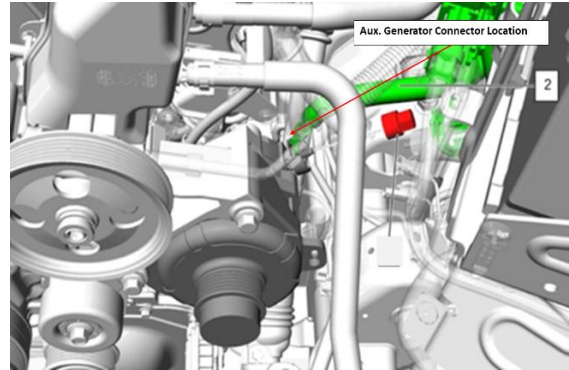
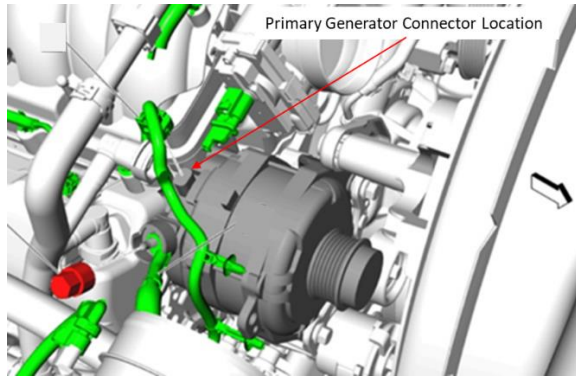

14) Remove the Intake Air Baffle per the service replacement procedure (link provided below)

[Intake Air Baffle Replacement](#)

15) Route the two wires of the harness such the taped portion is located as shown in figure (TBD) when the Intake Air Baffle is reinstalled. Route the harness with the connector and blunt cut wires out through the front grill like figure (TBD)

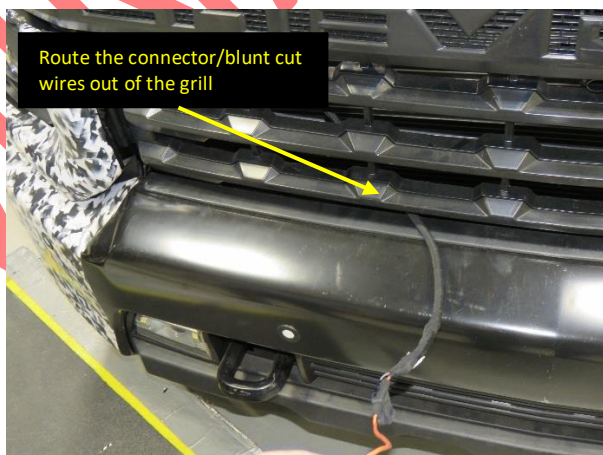
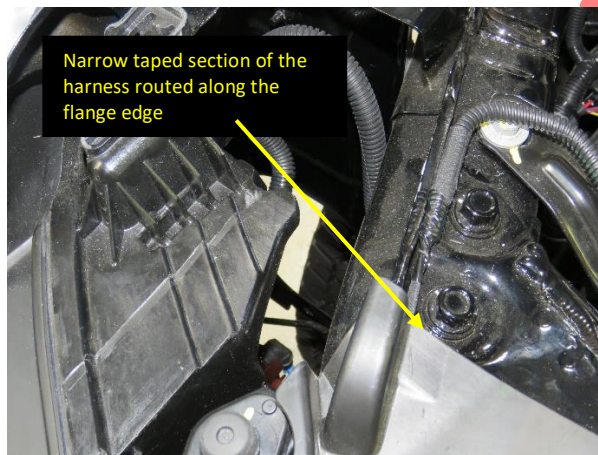

16) Reinstall all removed components.

17) The blunt wires will need to have the orange colored wire connected to power source that is active when the snow plow is being operated (moved) and the black wire to a ground source. This enables the relay to open the generator control circuit resulting on the generator operating at a base charging voltage and all but eliminating the "blank" condition of the vehicle control modules.

Subject: Intermittent Cluster, Radio and HVAC Display Resets on Snow Plow Trucks

Models/Years Affected: 2014 - 2018 Chevrolet Silverado 1500 LD
2015 - 2019 Chevrolet Silverado 2500-3500 HD
2014 - 2018 GMC Sierra 1500 LD
2015 – 2019 GMC Sierra 2500-3500 HD
With Snow Plow Prep Package (RPO VYU)

Origination Date: November 30, 2015

Revision Date: November 7, 2019

ADVISORY:

Notice: GM Dealers refer to the latest version of Service Information PIT#5387 for labor code/time information

REVISED TO UPDATE MODEL YEAR COVERAGE

Condition/Concern:

Trucks equipped with option VYU [Snow Plow Prep] and a snow plow, may exhibit occurrences in which the Instrument Panel Cluster (IPC), Radio and HVAC displays may “blank out” or reset after changing the snow plow position. This condition is caused by a system voltage over-shoot phenomenon called ‘load dump’. When the large electrical draw of the plow pump motor is suddenly removed the field energy that is built up in the alternator causes a system voltage overshoot that momentarily moves above the normal design operating levels for the module displays. As a result the displays will shut down or reset causing the momentary blank out condition. The modules are designed to do this and immediately recover. *No modules* should be replaced for this condition.

Repair/Recommendation:

Contact your local GM Dealer for an appointment to install **PN 84288774 VYU Snow Plow Jumper harness** per the latest version of **GM Service Bulletin PIT#5387**. If your truck has RPO VYU and did not come with the harness parts they may be ordered by your dealer.

Note: This jumper harness and installation will be provided [one time] without charge. Installation charges will be waived only if the jumper is installed at your GM dealer.

General Motors Upfitter Integration
<http://www.gmupfitter.com>

Installation Instructions**1) Single alternator systems:**

- a) Unplug the 2-way connector on the alternator.
- b) Identify the master alternator connector [at the very tip of the harness when it is fully extended]. Insert it in the alternator.
- c) Take the original alternator connector and plug it into the mating jumper harness connector.
Note: In this case the second alternator connector will be unused and will remain capped and tied to the harness bundle.

2) Dual alternator systems:

- a) Unplug the control connectors on both alternators.
- b) Identify the master alternator connector [at the very tip of the harness when it is fully extended]. Insert it in the 'master' alternator on the RH side of the engine.
- c) Identify the 'slave' alternator connector on the jumper harness and insert it in the LH 'slave' alternator. Insert the removed LH alternator connector into the [unwired] cap on the jumper harness.

3) All systems:**a) Service part [early] version:**

- i) Route the snow plow jumper harness along the existing harness routing where possible and secure the relay center with tie straps as shown in Details 3.1.1-3. Allow slack for engine roll and upright orientation of the relay center to prevent water intrusion/collection.

b) Factory shipped version [parts bag included with new vehicle]:

- i) Remove the harness and loose parts from the shipping bag/container. Locate the new corner brace pn 84234282 [it should be painted black but our pictures are of an unpainted part] and the nuts and bolts that will be used to attach the relay center portion of the harness.
- ii) For a complete *picture book sequence* for the installation see Details 3.2.1-7.
- iii) Route the snow plow jumper harness along the existing harness routing where possible and allow slack sufficient to secure the relay center to the [new flat] corner brace with the nuts and bolts included in the parts bag.
- iv) Remove the Radiator Air Upper Baffle and Deflector by unclipping it from the radiator.
- v) Remove and discard the LH front pencil brace as shown and install the new flat corner brace.
- vi) Attach the relay center to the corner brace and the brace top the truck as shown.

4) All systems final [signal] connection:

- a) An operating signal must be identified to operate the small relay in the jumper harness. This signal should go ON and OFF with the plow pump motor. The relay requires low power < 1 amp so most any signal will do without loading issues. The schematic shows the control terminals on the motor solenoid which is the most common connection point.
- b) Using a test lamp try various connection points on the plow control wiring to identify a signal that will illuminate the test lamp only when the motor is running.

Note:

Some plows will present hot [B+] to both motor solenoid control terminals until one side goes to ground. As long as the lamp works right the jumper can be connected the same way. Connect the blunt cut red and black wires across the same signal source as was used to operate the test lamp. Normally the red wire will go to B+ and black to ground. [If both connection points are at B+ when the motor is at rest then put the black wire to the side that goes to ground when the motor runs and the red one to the constant B+ connection.]

- c) If the operating signal must be obtained outside of the engine compartment [on the plow itself] then **two sets** of inline connector will be required. **[Order GM service kit, 2 each M 2W 19119346 and 2 each F 2W 19119765 connectors]** Using 2 sets of connectors will allow tethered caps to be fashioned for when the plow is disconnected. Secure the wires and caps appropriately to assure durability. See figure 4.

Additional Reference Information

Fig 1: Jumper harness wiring schematic

VYU Service Harness for both single and dual generator trucks

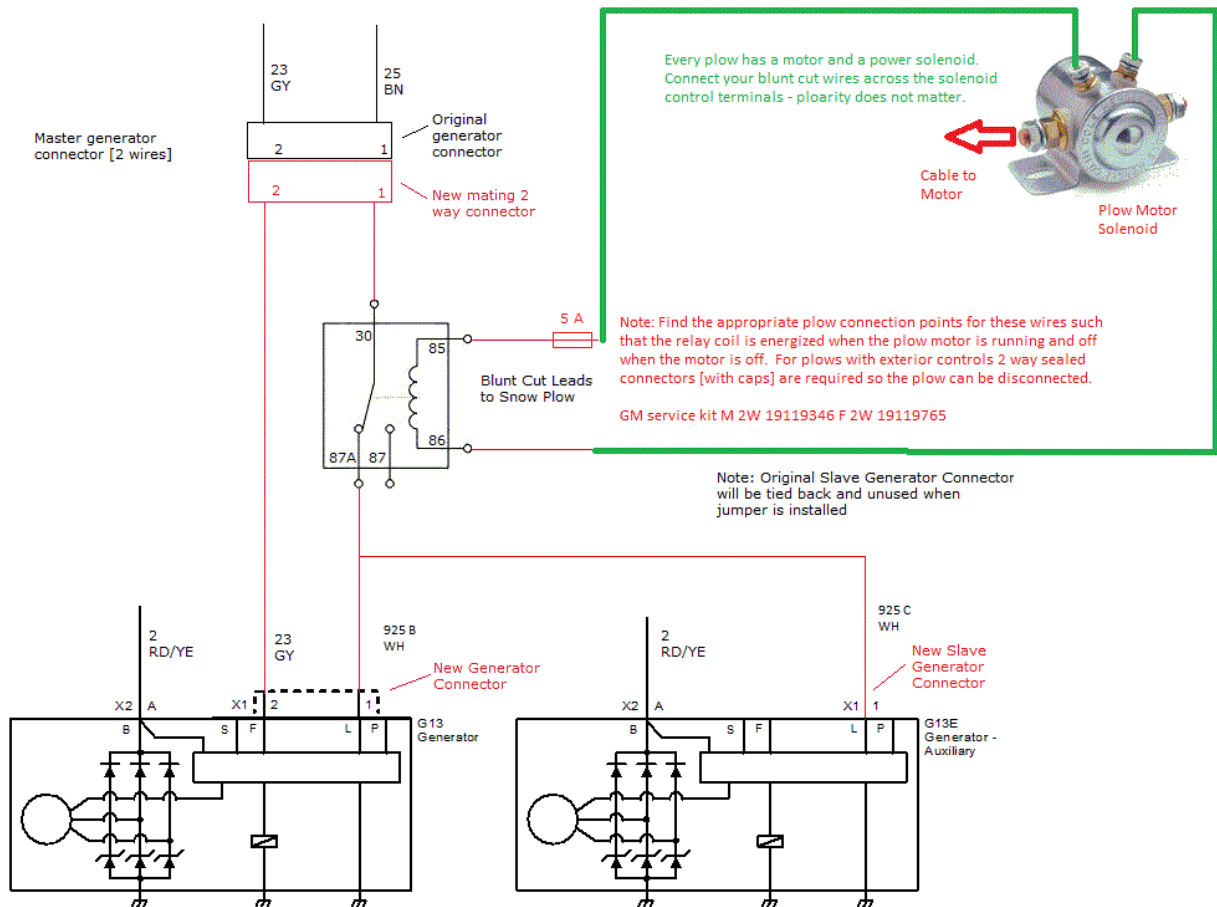

Note: To identify the signal needed by the jumper harness perform the following test. Any connection point that passes this test can be used. The best case is a signal from the wiring that remains with the truck but if that is not found then the signal must be found out on the plow itself.

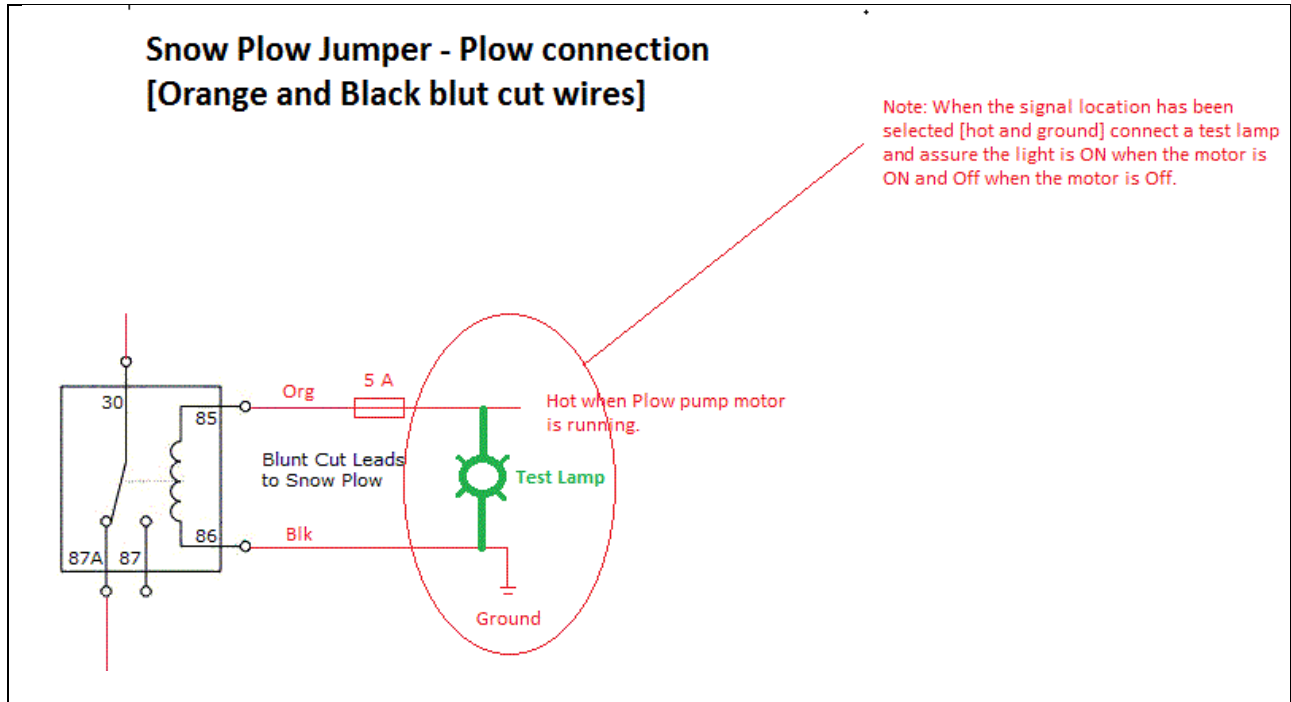

Fig: 2 Jumper Harness - Component Details

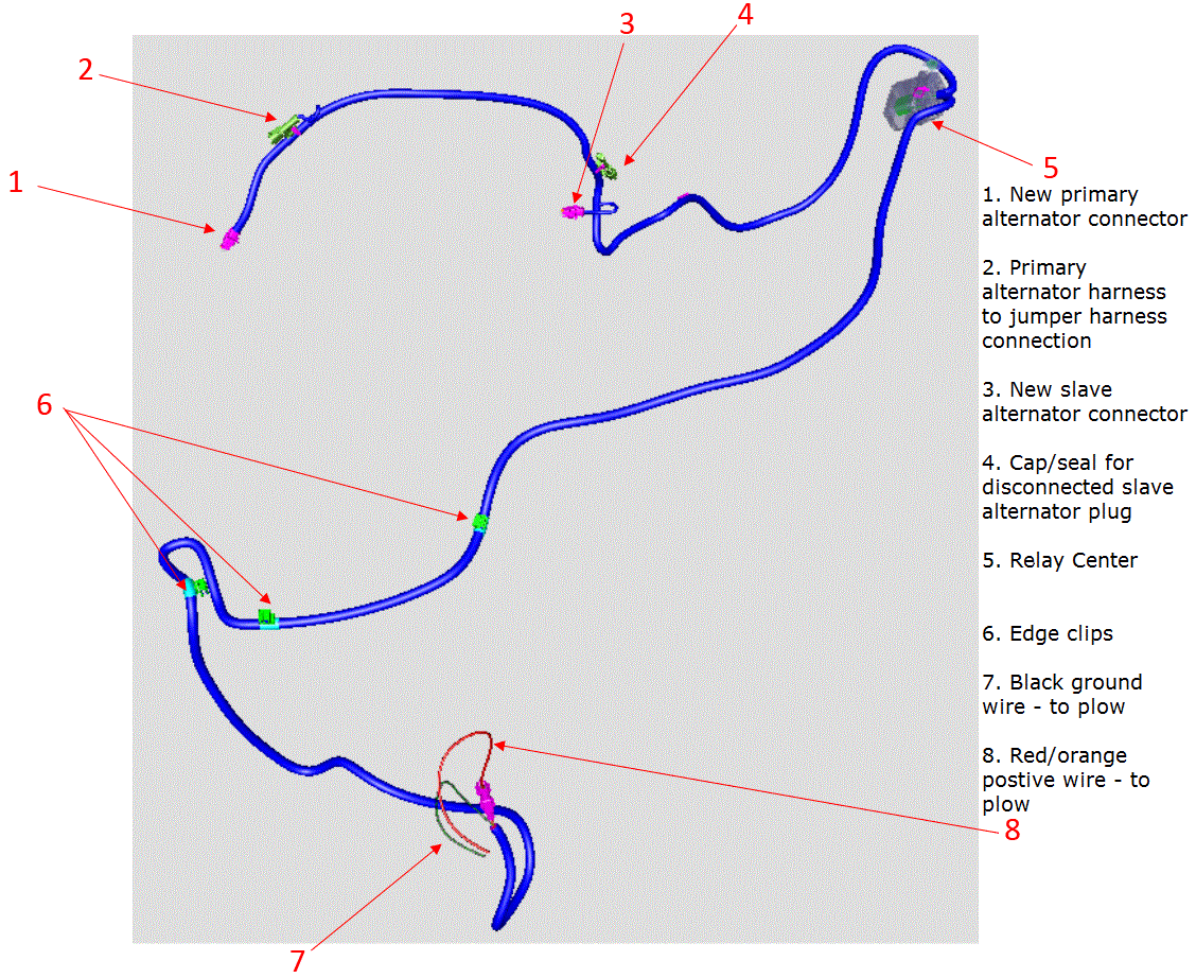

Fig: 3a Jumper Harness Layout – single alternator [see detail 3 for updated relay mounting]

VYU Single Alternator - Jumper Harness

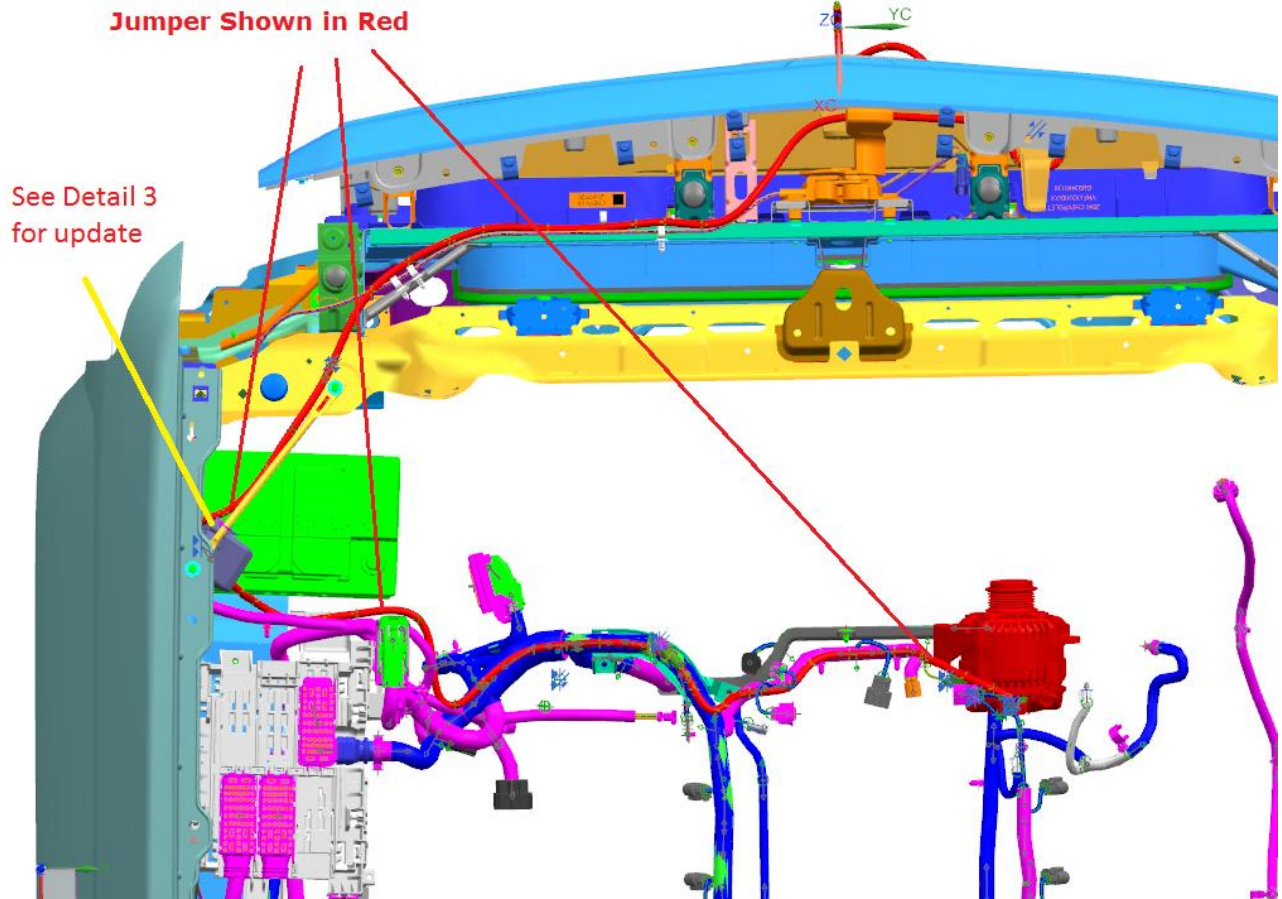
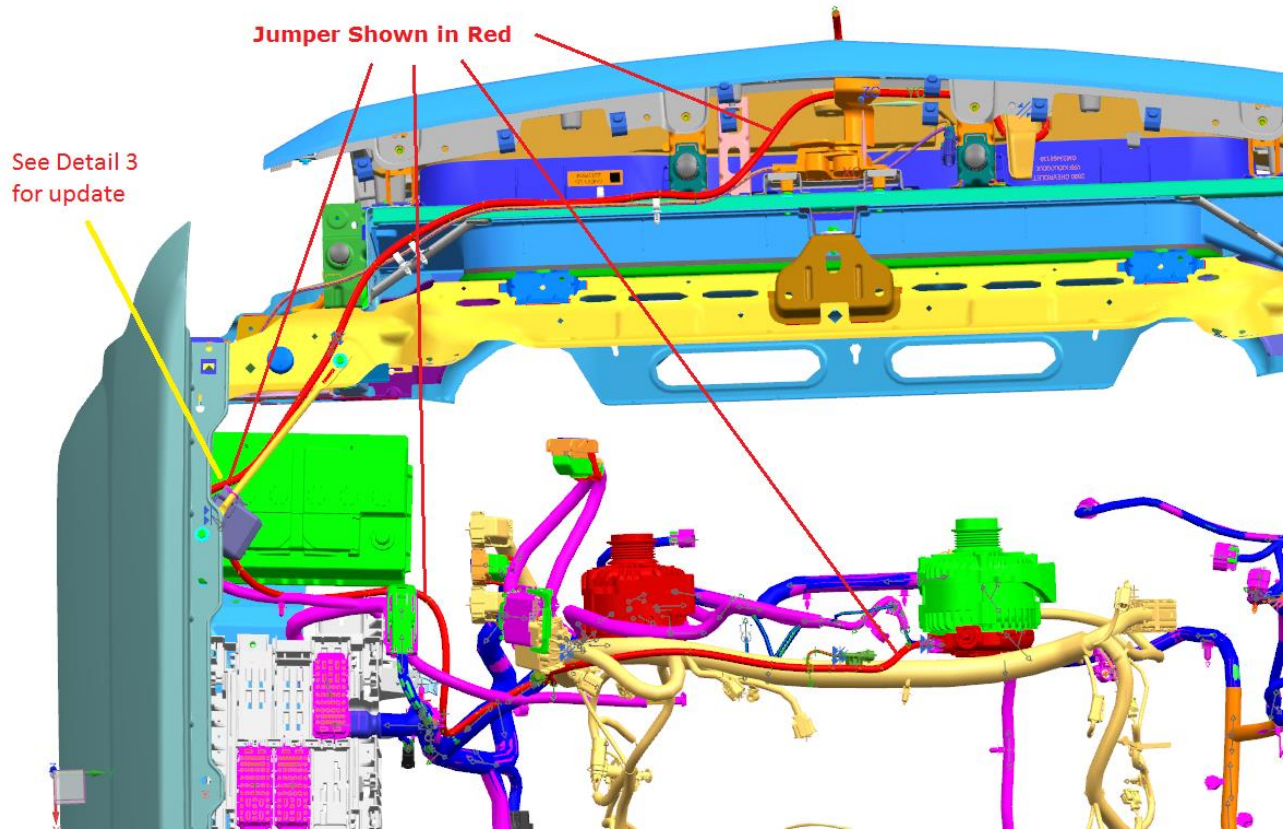

Fig: 3b Jumper Harness Layout – dual alternator [see detail 3 for updated relay mounting]

VYU Dual Alternator - Jumper Harness



General Motors Upfitter Integration
<http://www.gmupfitter.com>

Layout Details

- 1. Primary Alternator
- 2. Slave Alternator
- 3. Relay Center and [new] corner brace
- 4. Wires to plow [fused + & ground]

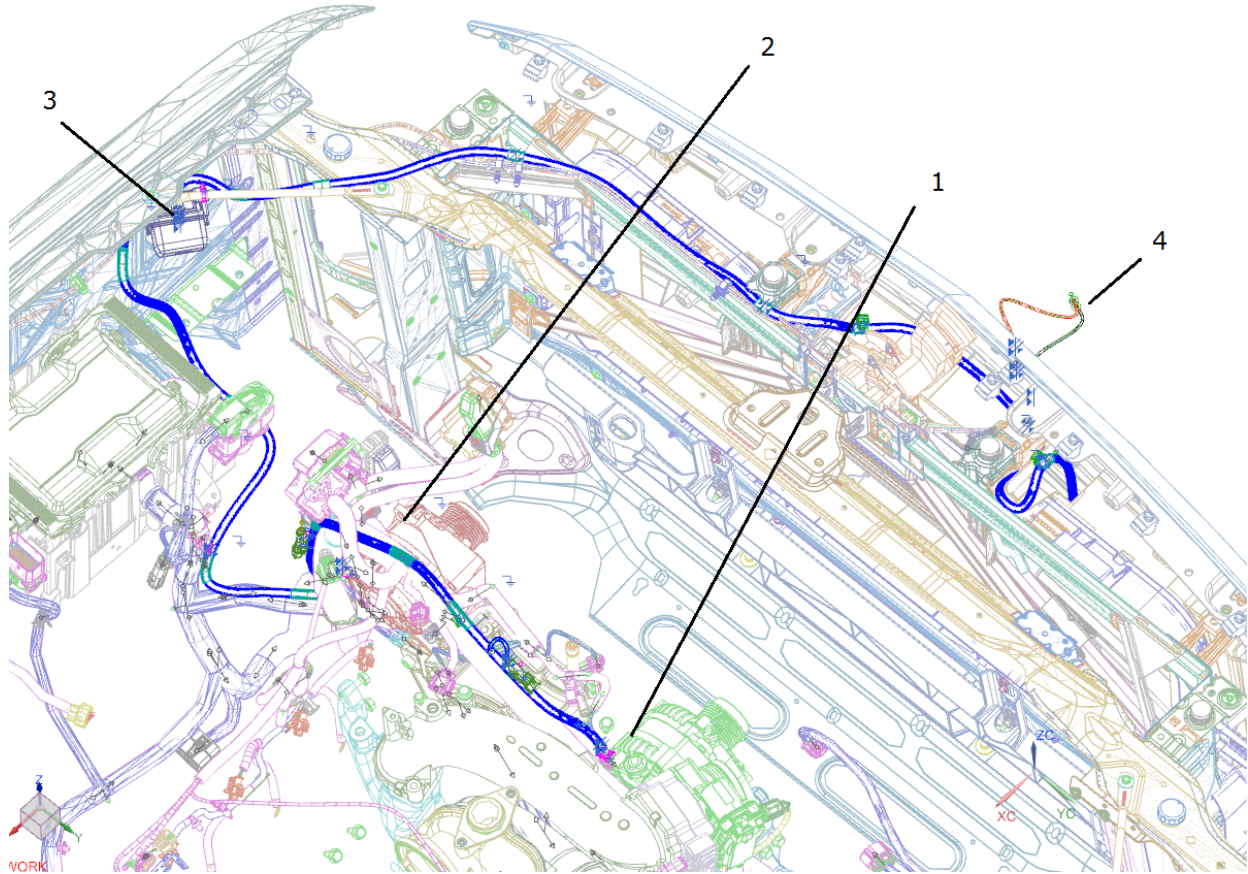

Detail 1

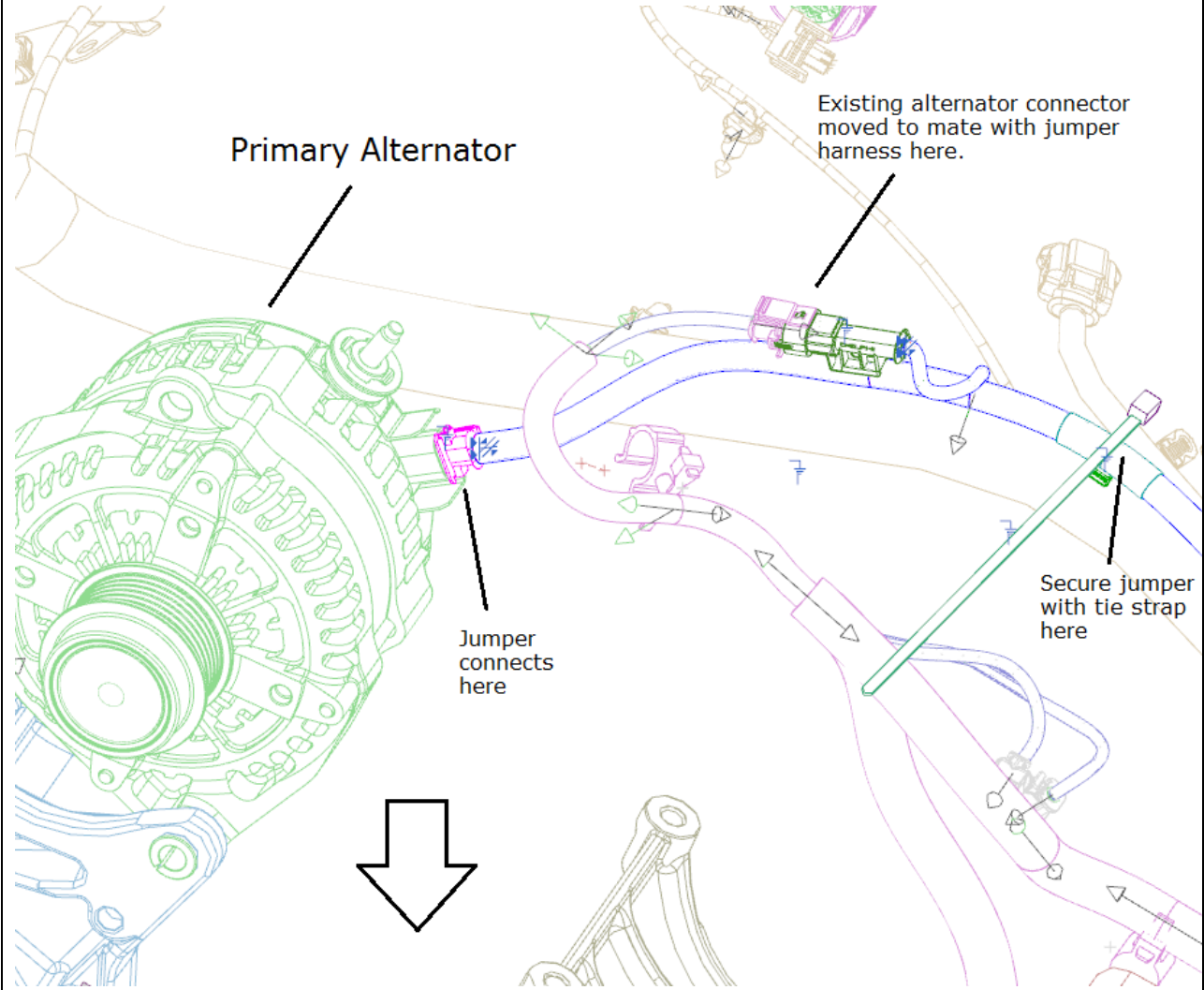

Detail 2

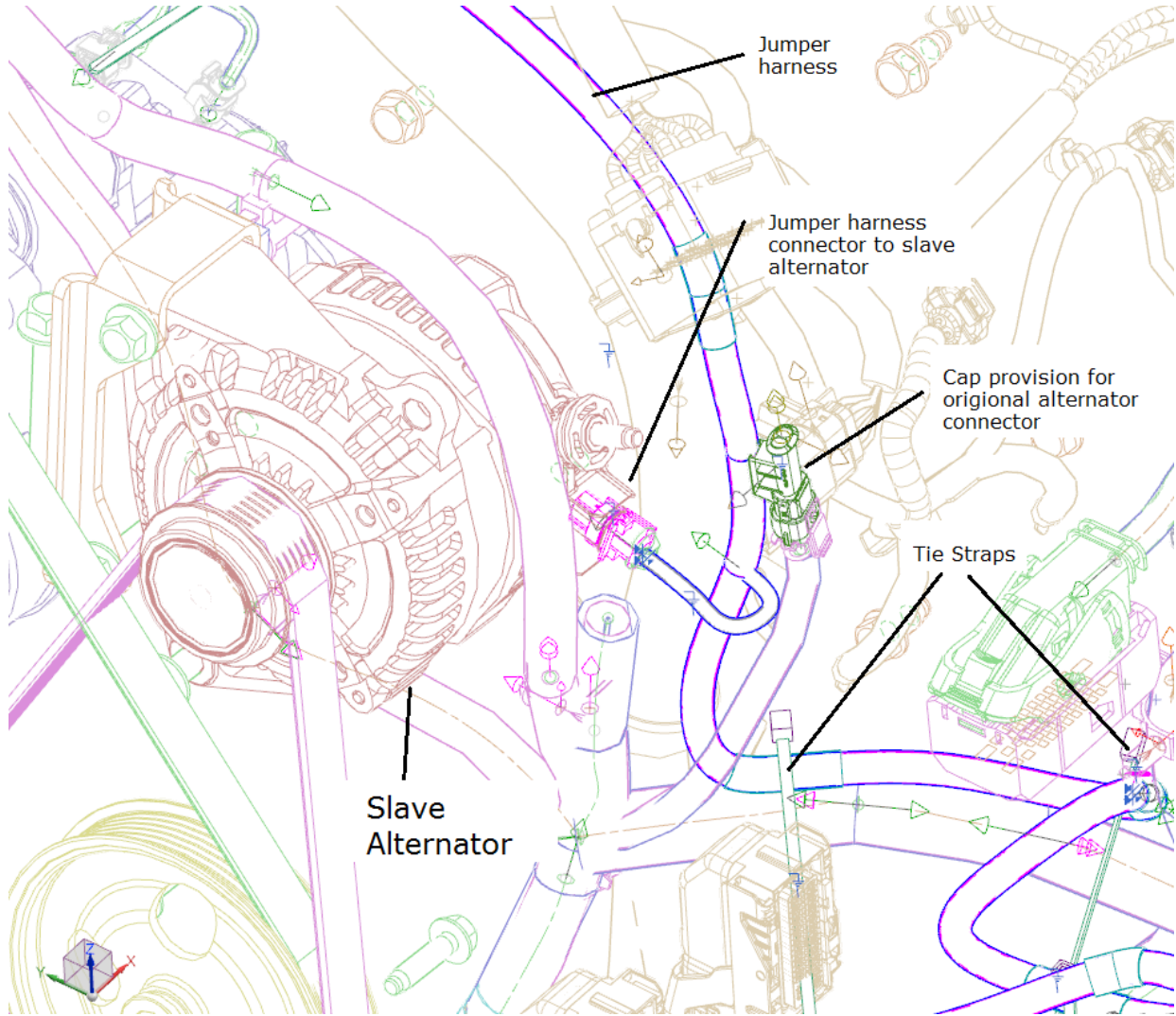

Detail 3.1.1

Details 3.1.1-3 apply to service part and not the factory included [loose shipped] part.

See Details 3.2.1-7 for the later version factory harness that comes with a new truck.

Add tie straps to relay

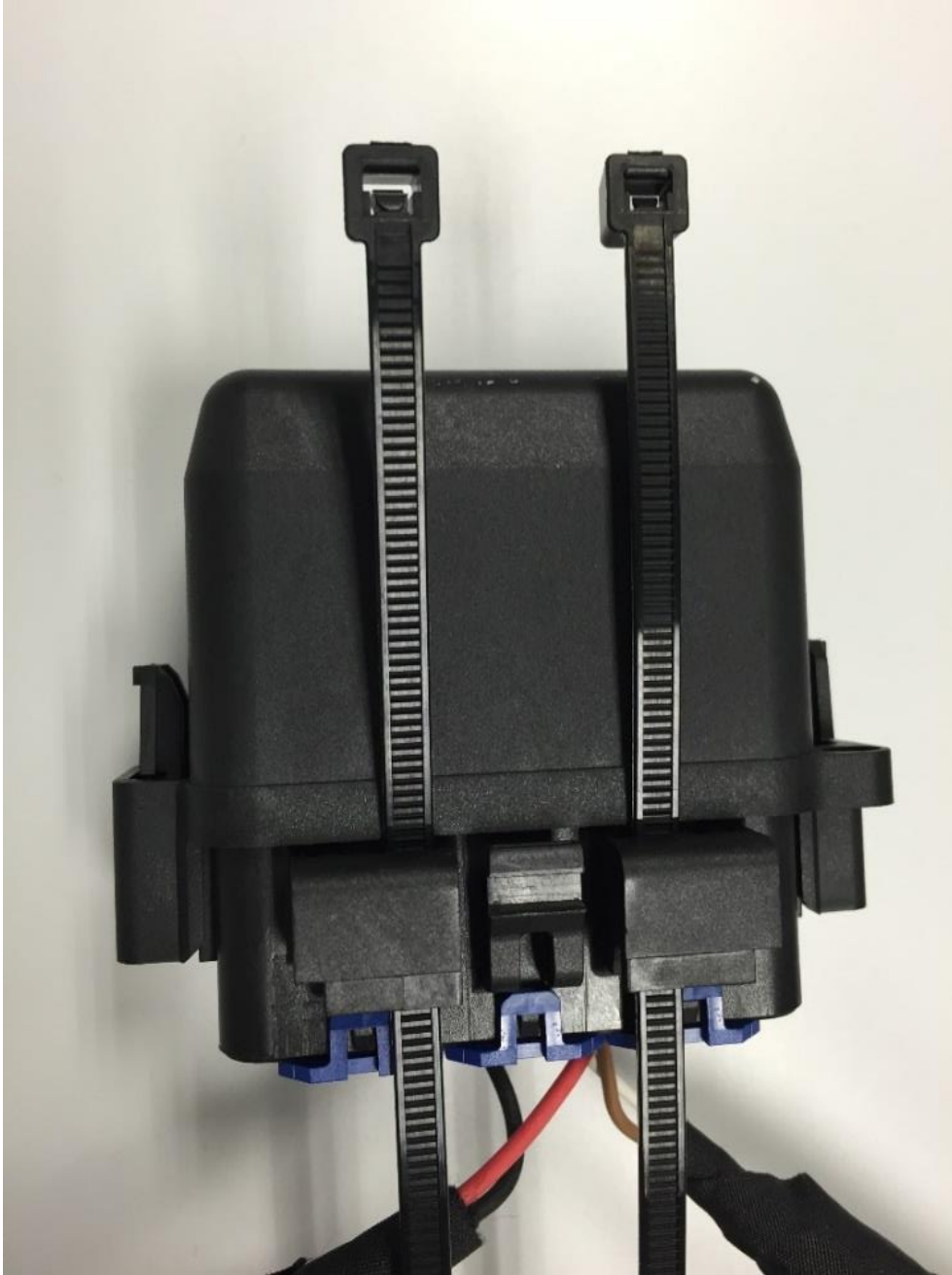

Detail 3.1.2

Single Battery Trucks

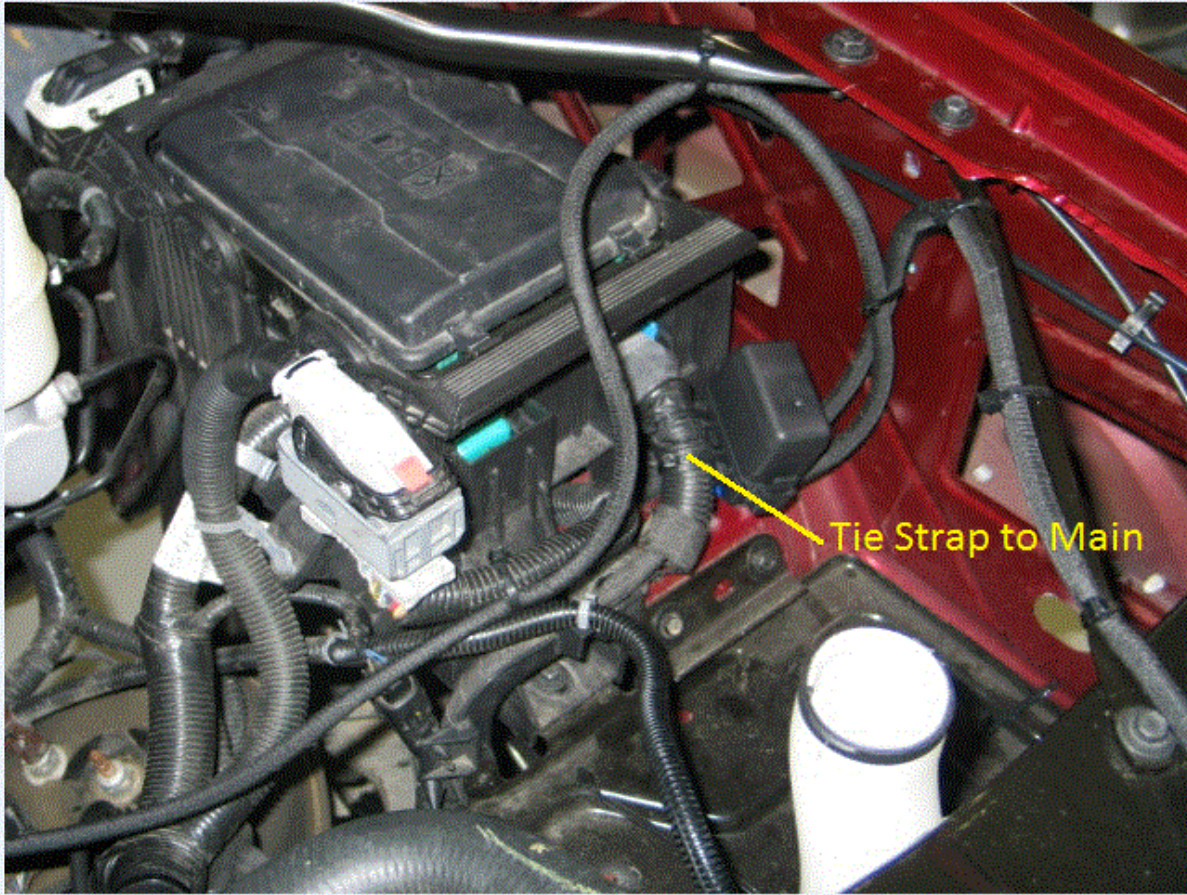

Detail 3.1.3

Dual Battery Trucks

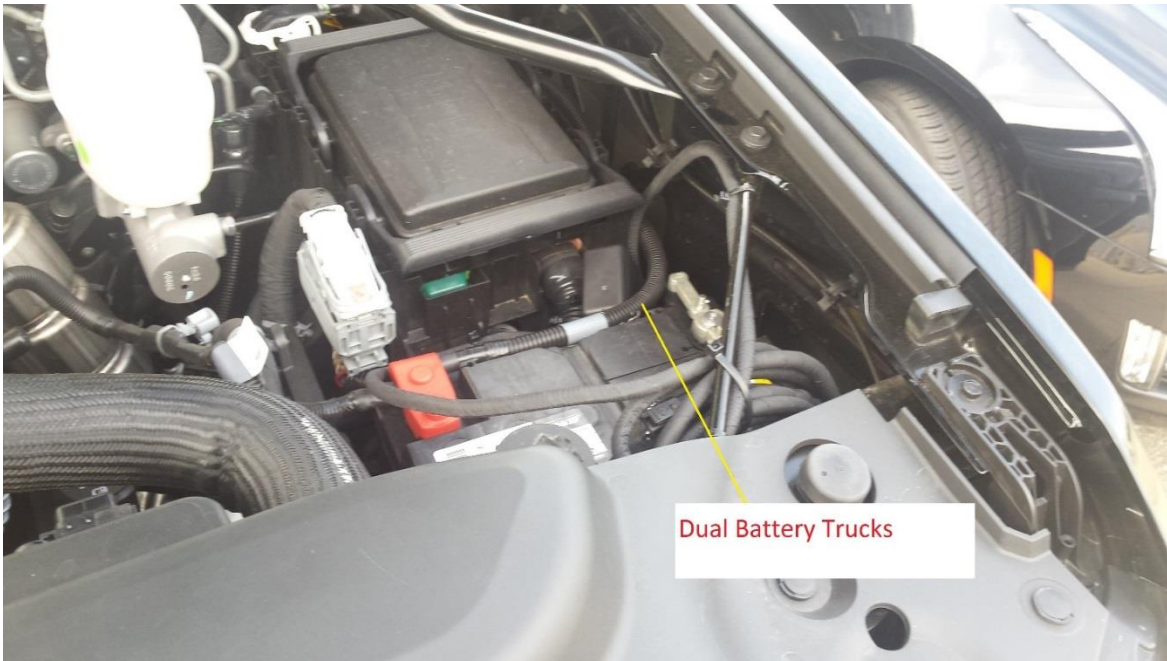

Detail 3.2.1

The following details 3.2.1 – 7 apply only to trucks that came with harness components [loose shipped] from the assembly plant.

Remove the Radiator Air Upper Baffle and Deflector.



Detail 3.2.2

Identify the new flat painted corner brace pn 84234282. [unpainted version shown]



Detail 3.2.3

Relay center and bracket details.



Detail 3.2.4

Remove the [round] left front corner brace shown here.

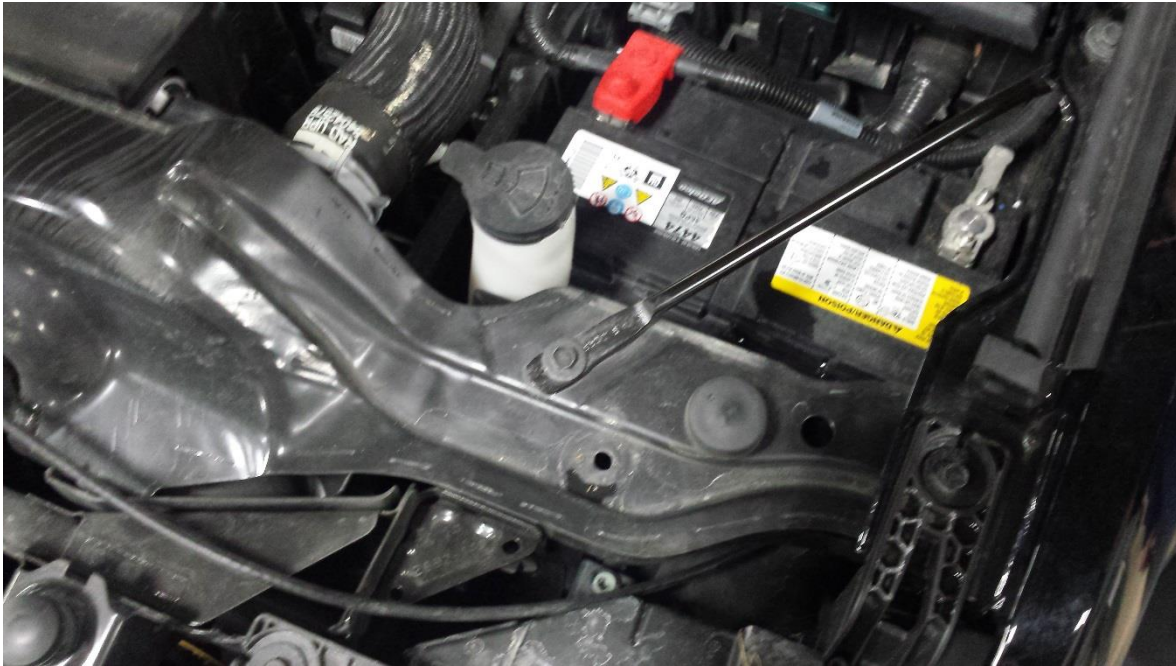

Detail 3.2.5

Assemble the relay bracket to the flat corner brace using hardware provided. Snap the relay bracket into the feature on the relay center.

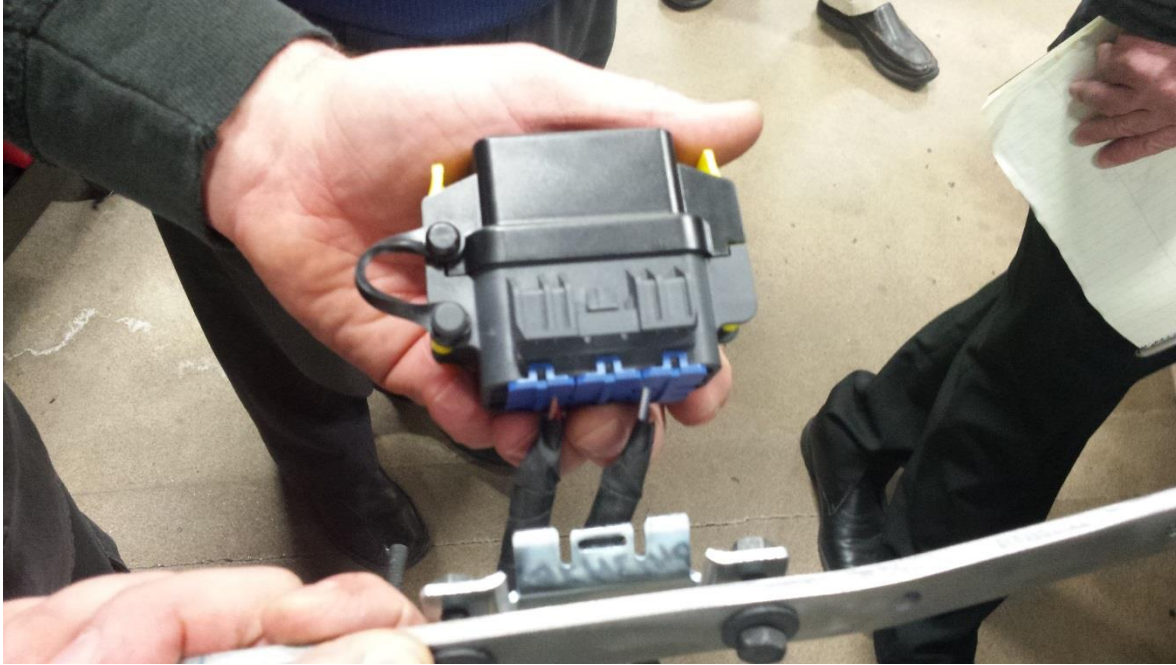

Detail 3.2.6

Position the corner brace and relay center assembly.



Detail 3.2.7

Mount the flat corner brace assembly as shown.

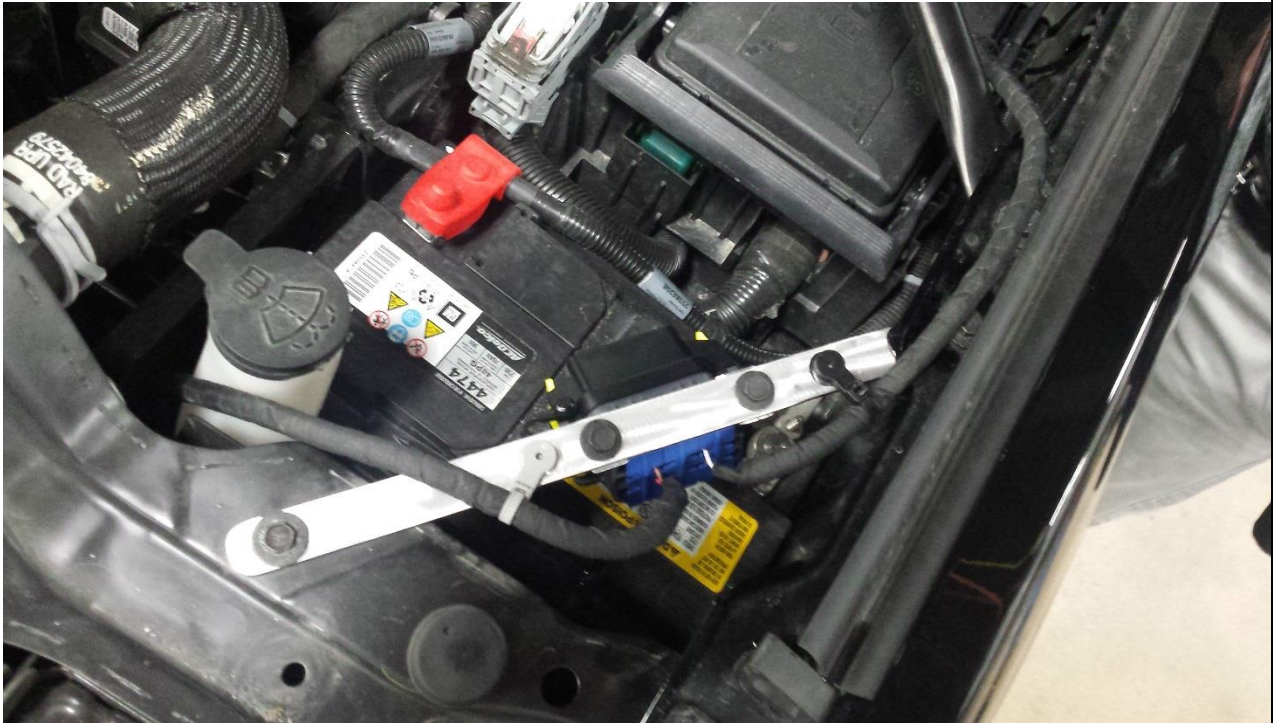

Detail 4

On units where the control signal must be obtained out on the plow wiring. **Two sets of 2-way sealed connectors** will be required as shown here. Extra mating halves can be used to fashion tethered caps. [Order GM service kit, 2 each M 2W 19119346 and 2 each F 2W 19119765 connectors]

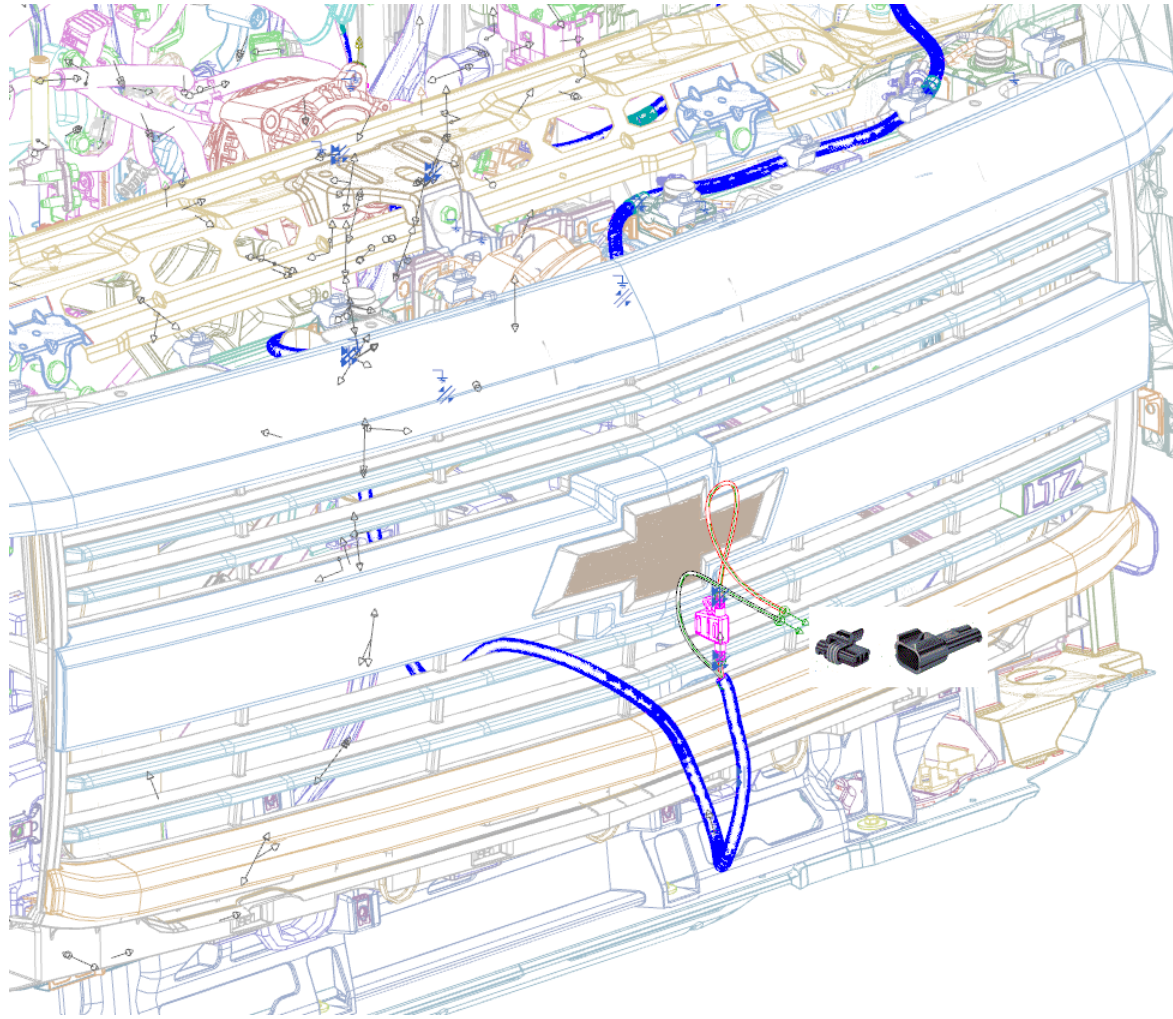



Subject: Elevated Engine Coolant/Operating Temperatures with Snow Plow Mounted

Models Years Affected: 2014 and beyond

Models Affected: Chevrolet Silverado

Models Affected: GMC Sierra
Upfitted with a Snow Plow

Origination Date: June 1, 2016

Revision Date: April 23, 2018

ADVISORY:

Condition/Concern:

Some customers may express concern about one or both of the following when a snow plow is attached to the front of the trucks:

1. Higher than normal engine or transmission temperature.
2. Incorrect outside temperature reading.

Both of the above conditions can occur due to the reduced airflow into the radiator area with the plow in the raised position. The air flow is diverted upward as a result of the raised plow and thereby does not enter the front grille area of the vehicle.

Repair/Recommendation:

In many situations, the following steps may improve air flow to the front of vehicle/grill area to improve cooling and/or reduce operating temperatures:

- Try lowering or repositioning (angling) of the plow.
- If repositioning attempts are unsuccessful in reducing the operation temperature, GM recommends that an air foil be added to the top of the plow, similar to the one shown below.

Note: Per vehicle Owner Manual "Caution: Do not exceed 64 km/h (40 mph) with a snow plow mounted to the vehicle. The vehicle could overheat and be damaged."



General Motors Upfitter Integration
<http://www.gmupfitter.com>



Subject: Snow Plow Lamp Activation
Models Years Affected: 2014 and Beyond
Models Affected: Chevrolet Silverado
 GMC Sierra
Origination Date: June 9, 2014
Revision Date: December 6, 2016

ADVISORY:

Condition/Concern:

Upfitters installing Snow Plows have requested additional information regarding the vehicle headlamp interface and the system function/requirements when the headlamps are switched from truck headlamps to plow mounted headlamps. Some customers have reported that one or both headlamps go off when attaching the plow and switching over to the plow lamps.

Repair/Recommendation:

For best results, switch lights to Park or OFF before connecting the electrical plugs when mounting the plow. This avoids current surges that could cause headlamp low beam shut down. Once the plow lights are connected the headlamps may be turned back ON.

Additional Information:

The plots below show the expected 'actual' headlamp current vs the 'over current' limits at headlamp activation. The BCM expects to see a single 'high current inrush and decay event' [current spike] as is normal with both incandescent and HID headlamps. If the headlamp circuit is switched [disconnected and then reconnected] after initial turn ON the subsequent [later] current spike may cause the diagnostic to turn the lamp off. Each time the headlamp is turned ON the diagnostic runs and a single current spike occurs. However, once normal running current is reached if a [later] second current spike occurs the BCM may turn off the lamp to protect the driver chip. Switching or interrupting the headlamp circuit causes current spikes. High current is not expected after lamp warm up and 'looks like' a short circuit.

Later version trucks have limited 'retry' provisions in the headlamp lamp diagnostic which renders the system somewhat tolerant to a 'switch over' event. [It will try a few times before shutting down.] Turning headlamps OFF at plow connection is best.

General Motors Upfitter Integration

<http://www.gmupfitter.com>



Figure 1: Over-current Plot 2014 - 2016

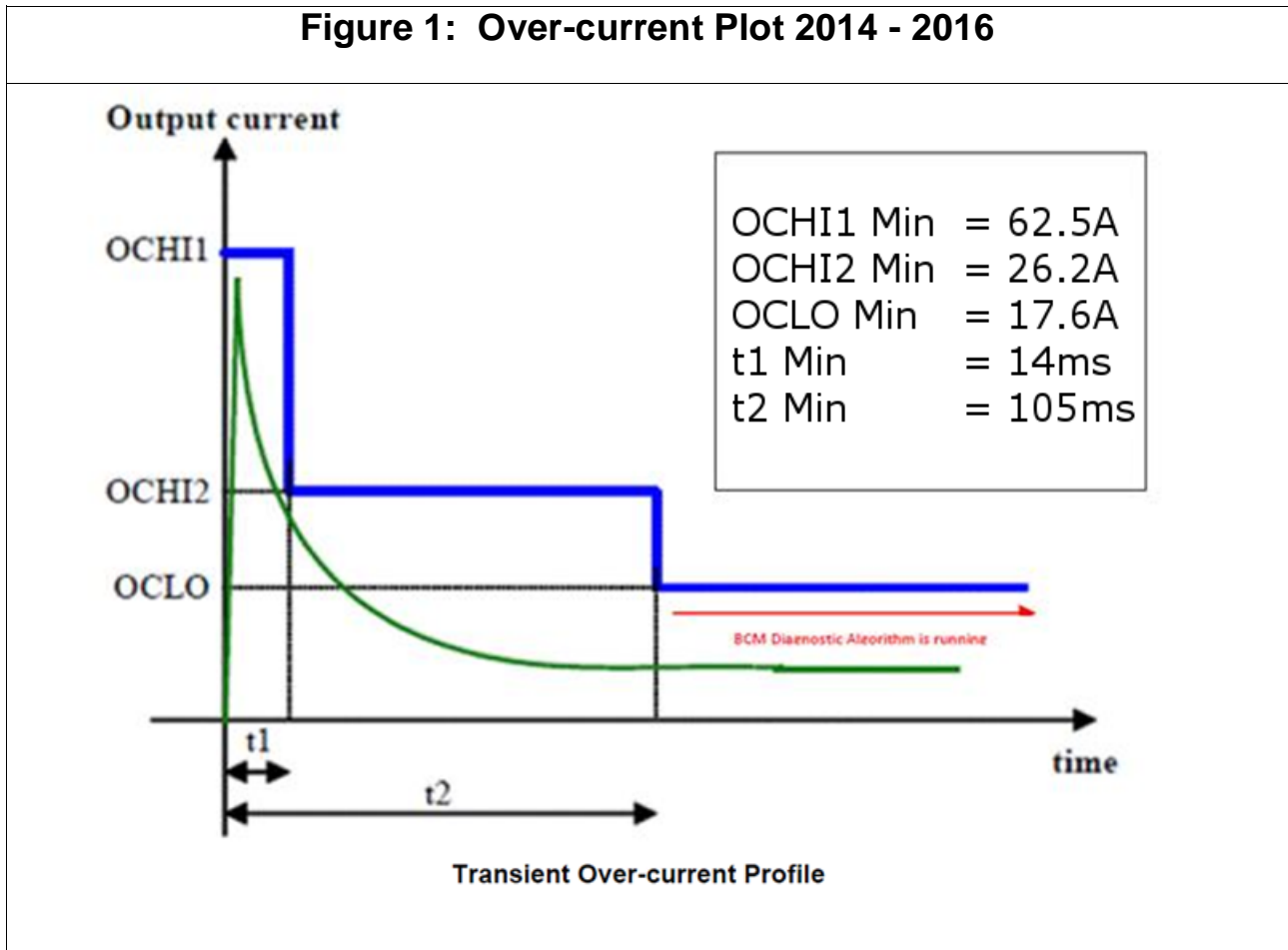
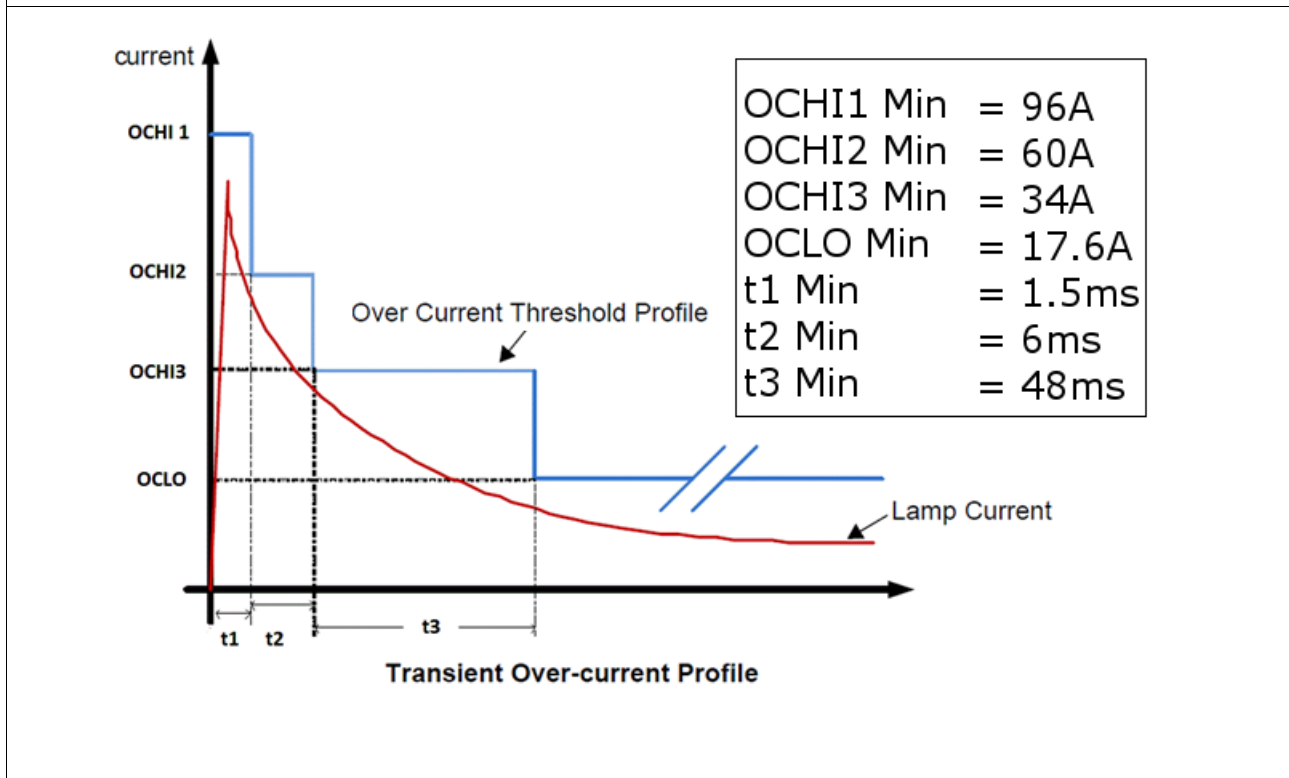



Figure 2: Over-current Plot 2017 and later [incandescent and HID]



0006X