

## Mounting kit 53633-MKPB-QLIV

F250 Super Duty 4x4 2017-2019  
F350 Super Duty SRW 4x4 2017-2019  
F350 Super Duty DRW 4x4 2017-2019  
F450/550 Super Duty 2017-2019

- Snowplow lights for 2017-2019, this kit requires:
  - 800084 or 80085 or 800086 Light Kit
  - 800092-MPX light adapter for Quad Lights
  - 800088-MPX for LED lights

See page #8 regarding technical bulletin on **Erractic operations of electrical features** with Snow plow and page #9 on **underhood electrical equipment mounting** for 2017& later Ford Superduty series

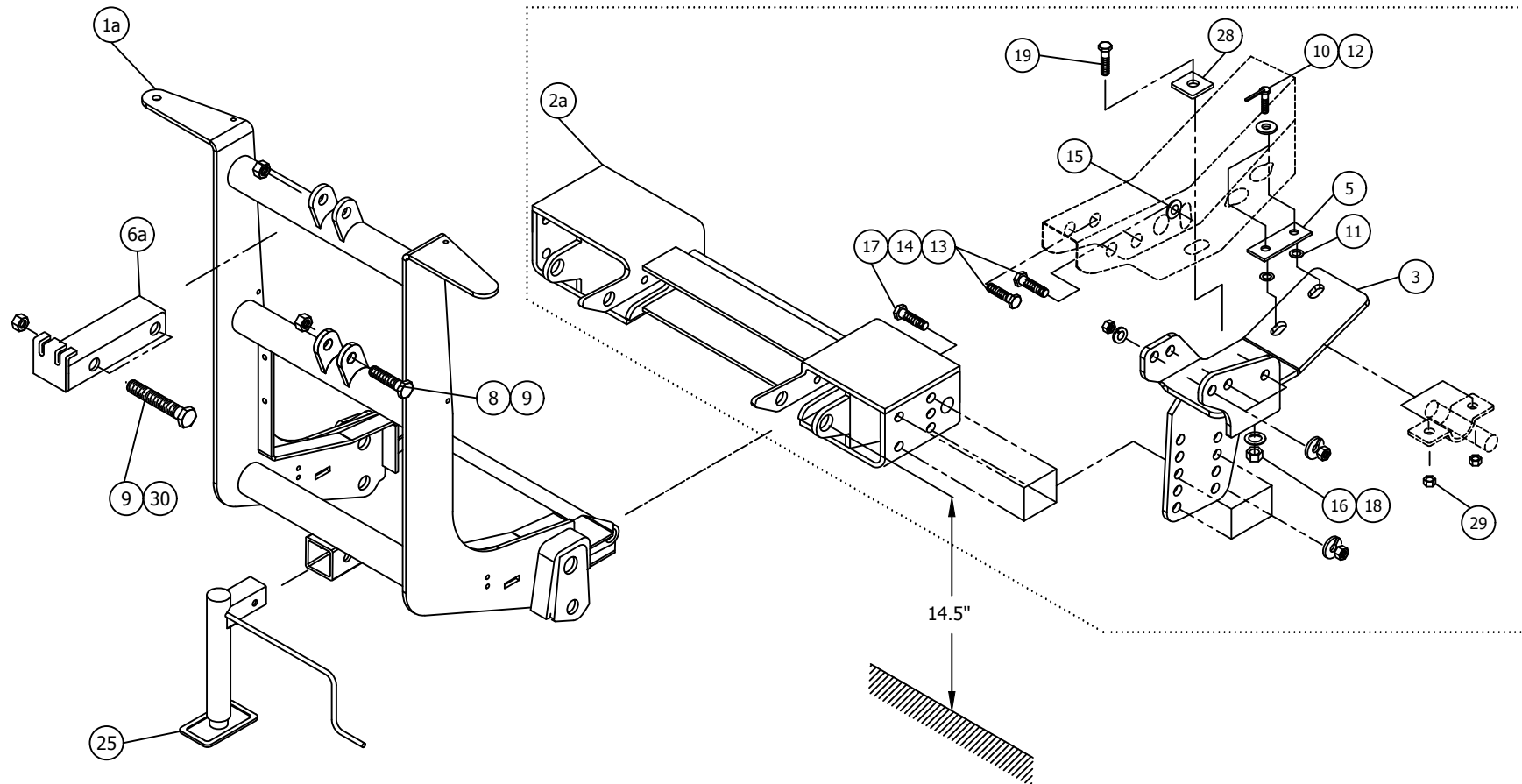

**Note:**

1. MKPB is shown by dotted lines.
2. All bolts are included in MKPB
3. Please use LOCTITE®, or similar locking product on ALL mounting hardware (bolts, nuts, etc.).

53633-MKPB-QLIV			
Item	Part #	Description	Quantity
1*	53171-D-GA	Lift Frame, QUIK*LINK® II-Hi boy	1
1a	53517-D	Lift Frame, QUIK*LINK® IV- Hi boy	1
1c*	53564-D	Lift Frame, QUIK*LINK® IV-Low mount	1
1d*	53424-D	Lift frame, QUIK*LINK® II- Low mount	1
2*	52364-C	Spreader Bar QLII	1
2a	53507-C	Spreader Bar QLIV	1
3	53635-01-B	Mounting Bracket DS	1
4*	53635-02-B	Mounting Bracket CS	1
5	53641-M	Spacer	2
6*	50069-C-GA	Lift Channel (1 ½" cylinder)	1
6a	52612-C-GA	Lift channel (2" cylinder)	1
7*	HH-00972-149	3/4" x 2½" UNF Cap screw	1
8	HH-00972-153	3/4" x 3½" UNF Cap screw	2
9	HH-00973-007	3/4" UNF Thin Collar Lock nut	3
10	52575-15-A	7/16" bolt with welded handle	4
11	53600-0011	7/16" Spring tension washer	4
12	HH-00341-005	7/16" Flatwasher	4
13	HH-00457-003	5/8" Lock washer	18
14	HH-00460-001	5/8" UNF Hex nut	18
15	HH-00341-008	5/8" Flatwasher	2
16	HH-00540-002	5/8" Lock Nut	2
17	HH-00972-129	5/8" x 1 3/4" UNF Cap screw	18
18	HH-00613-006	5/8" SAE Washer (1 3/8" outside diameter)	2
19	HH-00972-130	5/8" x 2" UNF Cap screw	2
20*	HH-00293-006	1/4" x 1" Cap screw	4
21*	HH-00457-006	1/4" Lock washer	4
22*	HH-00341-002	1/4" Flat washer	4
23*	HH-00294-001	1/4" Hex nut	4
24*	52348-M	Mounting Pin Assembly	1
25	52373-M	Jack Assembly	1
26*	50999-B	Blade guides	2
27*	53092-N	Black cable tie	1
28	53642-M	Washer	2
29	53600-0010	7/16" Lock Nut	4
30	HH-00972-155	¾" x 4" UNF Cap screw	1

QUIK\*LINK is a trademark of Arctic Equipment Manufacturing Corporation

\* These items are not shown on the drawing.

**▲ Warning**

Arctic Equipment Manufacturing Corporation (Arctic) does not assume liability for damage to your motor vehicle resulting from the attachment or use of an Arctic snowplow. The purchaser assumes all vehicle risk associated with the attachment and operation of this snowplow. The Arctic snowplow you purchase must be used only on vehicles equipped with the manufacturer's snow plow preparation packages. Snow plowing without the original plow preparation package may damage your vehicle. The added weight may impair the operation and control of your vehicle. Snow plowing with a vehicle not recommended for that purpose by the manufacturer may void your new vehicle warranty. If your vehicle is not equipped with an original snow plow preparation package, additional equipment may be necessary before snow plowing. Please consult your vehicle and snowplow dealers prior to the purchase and installation of the snowplow. The installation of such parts however is not a full substitute for the original equipment snowplow preparation package.

The loaded vehicle, including all aftermarket accessories, the snowplow, passengers and cargo, must not exceed the gross vehicle weight ratings (GAWR), front gross axle weight rating (FGAWR) or rear gross axle weight rating (RGAWR) specified on the Safety Compliance Certification Label located in the driver's side door opening. It is the operator's responsibility to verify that these ratings are not exceeded. The use of rear ballast weight may be required to prevent exceeding the front GAWR.

To determine the Gross Axle Weights for your vehicle, including all aftermarket accessories, the snowplow, passengers and cargo, take your loaded vehicle and the snowplow to a scale. With the snowplow attached, place the front wheels of the vehicle on the scale to get the front gross axle weight (FGAW). To get the rear gross axle weight (RGAW), place the back wheels of the vehicle on the scale.

## Installation Instructions

Before drilling any holes in the firewall or frame, move brake lines, fuel lines and/or electrical wiring from the path of the drill. Brake and fuel lines must also be clear of any fasteners. Do not under any circumstances disable, remove or relocate any sensors or other components related to the operation of the air bags.

General order of installation:

- install all components (mounting bracket, thrust arm and spreader bar) and all fasteners finger tight (snug) through existing holes,
- use removable grade LOCTITE #242 on all bolts,
- drill necessary holes and
- tighten all hardware.

After first use, re tighten all mounting bolts; thereafter check mounting bolt tightness periodically and at the start of the season.

Before proceeding, read instructions carefully and familiarize yourself with the components and hardware.

NOTE: It may be necessary, on some vehicles, to use a form of load booster to decrease the vehicle's front suspension sag when snowplows is attached to the vehicle. This can be done with the use of booster springs, supplementary air bags or similar load boosting devices. It is up to the customer to choose and purchase the product that suits this application.

Arctic Equipment Manufacturing reserves the right, under its product improvement policy, to change construction, design details or specifications without notice or without incurring any obligation.

1. Remove a bumper from the truck. Remove the two brackets.



2. Remove four nuts that hold a sway bar to the vehicle frame (bolts/nuts will not be used – store in a safe place to return vehicle to stock settings after the mounting kit is removed).



3. Insert 7/16" bolts with welded handle (10) with 7/16 flatwasher (12), in the vehicle frame as shown on the pictures.



4. Slide the spacer (5) on the bolts (10) and insert the spring washers (11) on the 7/16 bolts to keep the spacer in the place (against the frame).



5. Install the mounting bracket (3)(4) on the vehicle frame using 5/8" bolts, lockwasher and nuts. Tighten 7/16" lock nuts (29) – the sway bar bracket to the mounting bracket (3)(4). See the drawing.

Note: Use a 5/8" flatwasher (15) under the bolt on the slotted hole in the frame on the side. Also use 5/8" x 2" (19) bolt that goes through the bottom of the vehicle frame (use also washer inside of the plate (28), 5/8" flatwasher (18) and 5/8" locknut (16).

6. Install spreader bar (2a) using 8 x 5/8" bolts, nuts and lock washers (17,14, 13). Snug 5/8" nuts. The spreader pin hole should be 14 1/2" (+/- 1/2") off of the ground.

7. Install all bolts from the inside of vehicle frame and secured with nuts outside of frame. Torque all fasteners according to torque chart.

8. Remove the bottom air dam from the bumper and relocate the harness under the cover on the bumper. Use zip ties to secure a harness.

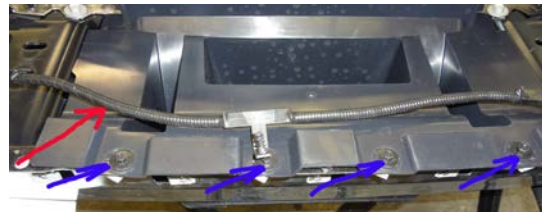

Relocate the harness by removing the screws under the bumper cover.

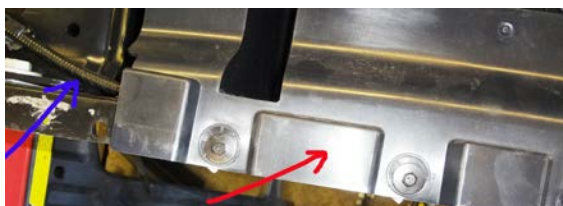



Use zip ties to secure a harness.



9. Reinstall bumper. Install lift frame (1a). Slide inside of spreader bar (2a).

10. Install lift channel (6a) and hydraulic cylinder to lift frame (1a) using 3/4" x 3 1/2" bolts (8) and 3/4" locknuts (9). Use 3/4" x 4" bolts (30) (for wider lift channel) or 3/4" x 2 1/2" bolt(7) (for narrow lift channel) and 3/4" lock nuts (9) to attach lift channel (6a) to the hydraulic cylinder. Do not over tighten this assembly as it must be able to pivot.

11. Use 1/4"x 1" bolt (20), 1/4" flat washer (22), 1/4" lock washer (21) and 1/4" hex nut (23) to fasten blade guides to plow.

12. Return any unused items to the customer so that the vehicle can be returned to its original condition if the snowplow is removed.

13. See separate installation instructions for the hydraulic power unit, wiring and controls.

Suggested torque value for bolts				
Thread Size	Grade 5		Grade 8	
	Dry (ft. lb)	Oiled (ft.lb)	Dry (ft. lb)	Oiled (ft.lb)
1/4-20	8	6	12	9
1/4-28	10	7	14	11
5/16-18	17	13	24	18
5/16-24	19	15	27	21
3/8-16	31	24	44	34
3/8-24	35	27	49	38
7/16-14	49	38	70	54
7/16-20	55	42	78	60
1/2-13	75	58	105	82
1/2-20	85	65	120	90
5/8-11	150	115	210	165
5/8-18	170	130	240	185
3/4-10	270	205	375	290
3/4-16	295	230	420	320
7/8-9	395	305	605	455
7/8-14	435	335	670	515
1-8	590	455	905	695
1-14	660	510	1030	785

Arctic Equipment Manufacturing Corporation reserves the right under its product improvement policy to change construction or design details and furnish equipment when so altered without reference to illustrations or specifications used herein.

**Q-269R2**



## SVE BULLETIN

### SPECIAL VEHICLE ENGINEERING – BODY BUILDERS ADVISORY SERVICE

E-Mail via Website: [www.fleet.ford.com/truckbbas](http://www.fleet.ford.com/truckbbas) (click "Contact Us")

Toll-free: (877) 840-4338

QVM Bulletin: Q-269R2

Date: 02 March, 2017

Revised: 21 July, 2017

## Erratic Operation of Electrical Features with Snow Plow and Other High Electrical Load Devices

Revision	Update	Revision Date
Q-269R2	• Added 6.7L Diesel TSB information	21 July, 2017

**Models Affected:**

2017 F-Super Duty – All Models with:  
6.2L & 6.8L Gasoline Engine built on or before 08 April, 2017  
6.7L Diesel Engine built on or before 12 May, 2017

**Issue:**

Some 2017 F-Super Duty vehicles equipped with a 6.2L or 6.8L gasoline engine built on or before 08-Apr-2017 or with a 6.7L diesel engine built on or before 12 May, 2017 may exhibit any or all of the following concerns at times of high electrical system draw such as snow plow operation: instrument cluster backlighting inoperative, erratic climate control blower motor operation, red brake warning indicator flickering, and/or low battery - features temp turned off message in the message center.

**Solution:**

**6.2L / 6.8L Gas:** Technical Service Bulletin #TSB 17-0043 has been issued to Ford Dealerships. The dealer should follow the Service Procedure steps contained in the TSB to correct the condition.

**6.7L Diesel:** Technical Service Bulletin #TSB 17-0052 has been issued to Ford Dealerships. The dealer should follow the Service Procedure steps contained in the TSB to correct the condition.

Please contact your servicing Ford Dealer for more information on this TSB and service procedure.

Revision History		
Revision	Update	Revision Date
Q-269R1	• Updated to reflect current TSB information	19 May, 2017



## SVE BULLETIN

SPECIAL VEHICLE ENGINEERING – BODY BUILDERS ADVISORY SERVICE

E-Mail via Website: [www.fleet.ford.com/truckbbas](http://www.fleet.ford.com/truckbbas) (click "Contact Us")

Toll-free: (877) 840-4338

QVM Bulletin: Q-277

Date: 29 August 2017

### Under Hood Electrical Equipment Mounting

**Models Affected:** 2017 and later Model Year Super Duty Pickups and Chassis Cabs

**Description:** *Ford has received a number of reports of upfitted chassis cab trucks that have experienced electrical grounding concerns, resulting in interior smoke, odor, and in some cases, fire. Ford recently investigated this concern with several upfitters and concluded the cause was aftermarket electrical equipment involving B+ power contacting the underside of the hood.*

The purpose of this bulletin is to bring this concern to your attention, inform you that the 2017 Super Duty under hood layout and primary battery location has changed from 2016 and prior models, and provide guidance is on:

- recommended placement of electrical equipment being installed in the engine compartment and
- minimum clearance to the hood (specifically for battery positive (B+) related components).

Electrical equipment added to the engine compartment during any aftermarket installations / modifications must be positioned to prevent any B+ power from coming into contact with the underside of the hood when closed. All B+ related equipment must be placed / routed per recommendations within this bulletin, adequately retained, shielded / covered, and confirmed to have clearance to the hood when closed to prevent unintended battery short to ground and damage to vehicle wiring (e.g. radio antenna and radio harness within the instrument panel).

Do not mount or place electrical equipment, including but not limited to connection terminals, cables, relays, fuses, and fusible links on top of or near the primary or secondary battery in a location that has low clearance to the underside of the hood as indicated by orange rectangles in the figures that follow.

The reduced clearance to the underside of the hood for added electrical equipment on top of or near the primary or secondary battery may not be apparent when the hood is open. **If any B+ equipment is mounted in the low clearance zone as indicated by the diagram, a minimum of 15mm must be confirmed between bottom of hood and any equipment (including any B+ shielding and under hood insulation) mounted in the engine compartment when hood is fully closed.** Several methods exist to confirm equipment and shielding meets minimum clearance to bottom of hood (e.g. clay test, bore-scope).

**The upfitter must ensure that any electrical equipment or shielding mounted under hood does not come into contact with the hood or hood components.**

**Figure 1:** 2017 Super Duty Under Hood Plan View. Low clearance to underside of hood in areas highlighted in orange

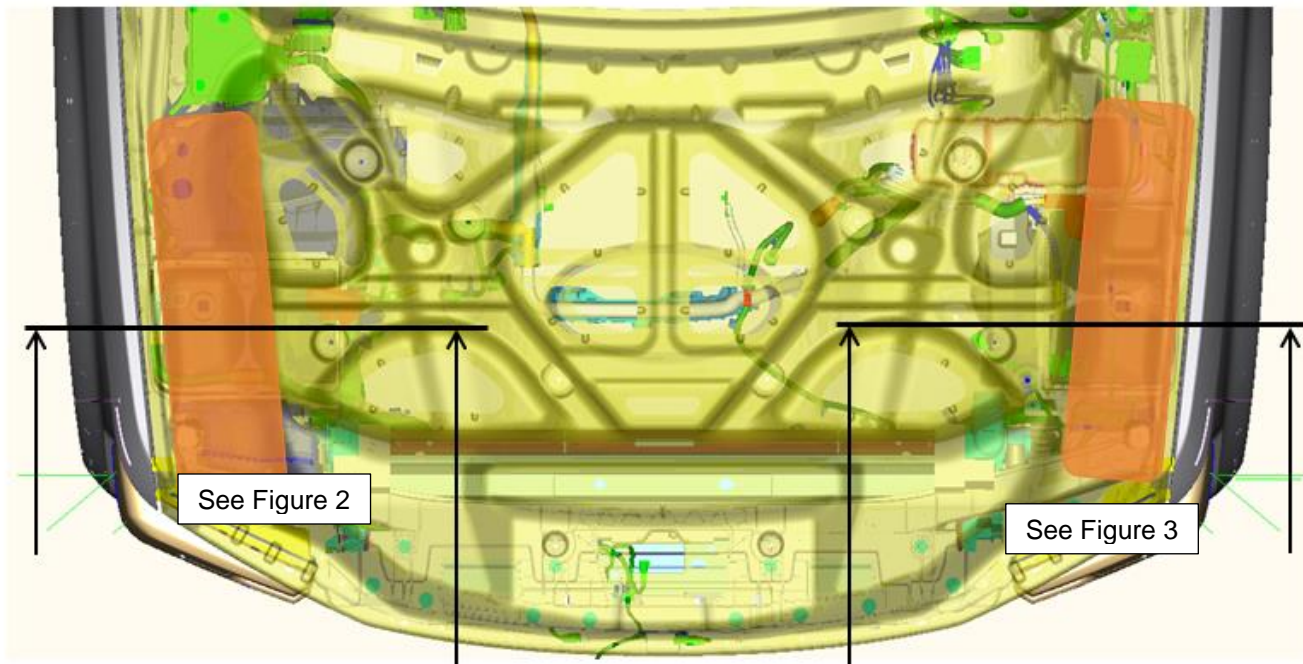

**Figures 2 & 3:** Vehicle X-Sections. low clearance areas (orange rectangles) for aftermarket equipment between battery & hood inner

**Note:** only 16 mm clearance from top of negative terminal assembly to underside of hood

