

Mounting Kit 53753-HOP

K1500 GMC/Chevy 4x4 1500 2019-2020

Refer to label in glove box for model number.

"All New" style (2nd # in model # is 0 not 5) example: K10753
Use 53753 mounting kit

For "Classic" style (2nd # in model # 5 not 0) example: K 15753
use 53247 mounting kit.



For snowplow lights, this kit requires:
800084 or 800086 light kit.
800104-MPX light adapter for Front Installation

▲ Warning

Arctic Equipment Manufacturing Corporation (Arctic) does not assume liability for damage to your motor vehicle resulting from the attachment or use of an Arctic snowplow. The purchaser assumes all vehicle risk associated with the attachment and operation of this snowplow.

The Arctic snowplow you purchase must be used only on vehicles equipped with the manufacturer's snow plow preparation packages. Snow plowing without the original plow preparation package may damage your vehicle. The added weight may impair the operation and control of your vehicle. Snow plowing with a vehicle not recommended for that purpose by the manufacturer may void your new vehicle warranty. If your vehicle is not equipped with an original snow plow preparation package, additional equipment may be necessary before snow plowing. Please consult your vehicle and snowplow dealers prior to the purchase and installation of the snowplow. The installation of such parts however is not a full substitute for the original equipment snowplow preparation package.

The loaded vehicle, including all aftermarket accessories, the snowplow, passengers and cargo, must not exceed the gross vehicle weight ratings (GAWR), front gross axle weight rating (FGAWR) or rear gross axle weight rating (RGAWR) specified on the Safety Compliance Certification Label located in the driver's side door opening. It is the operator's responsibility to verify that these rating are not exceeded. The use of rear ballast weight may be required to prevent exceeding the front GAWR.

To determine the Gross Axle Weights for your vehicle, including all aftermarket accessories, the snowplow, passengers and cargo, take your loaded vehicle and the snowplow to a scale. With the snowplow attached, place the front wheels of the vehicle on the scale to get the front gross axle weight (FGAW). To get the rear gross axle weight (RGAW), place the back wheels of the vehicle on the scale.

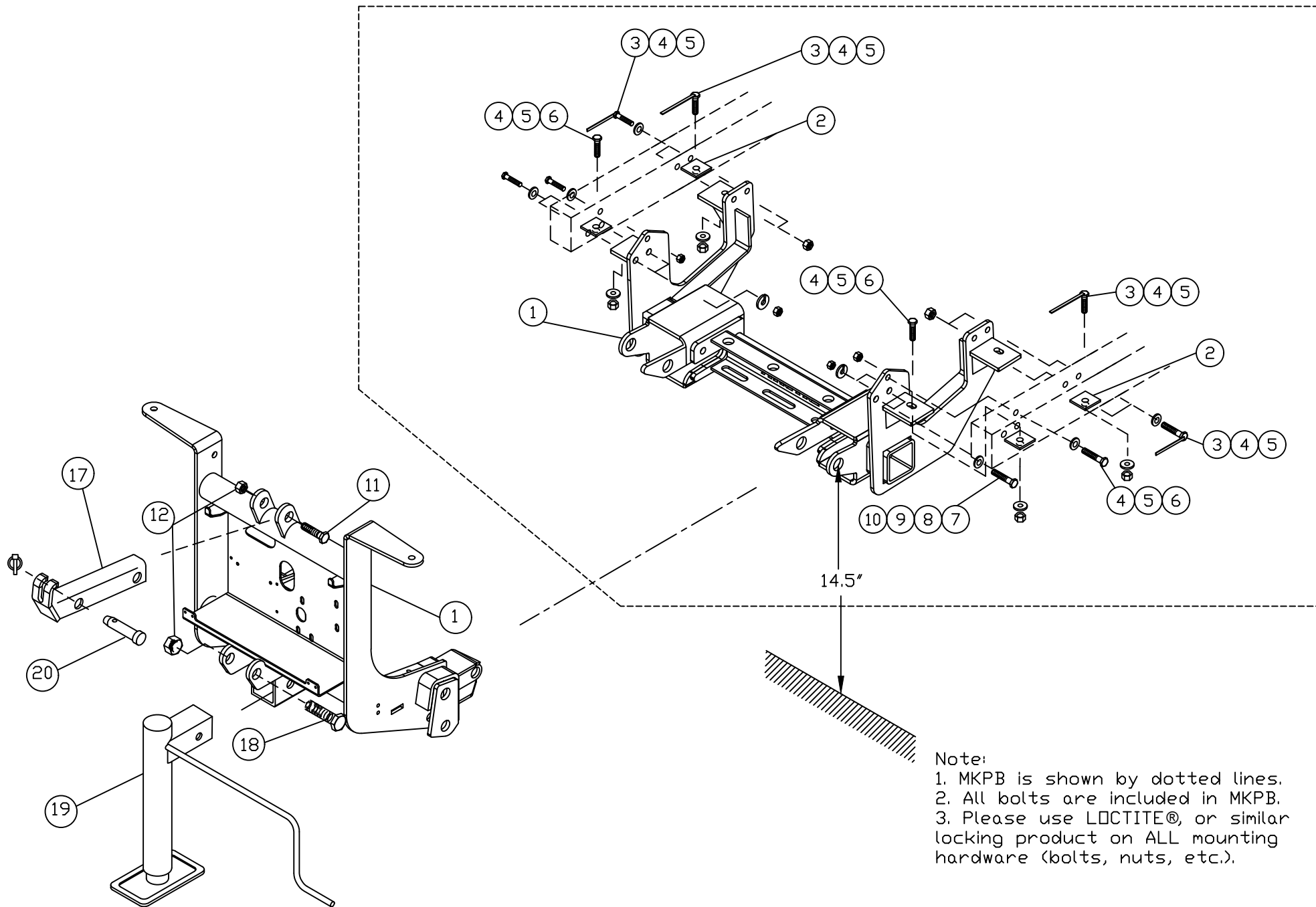

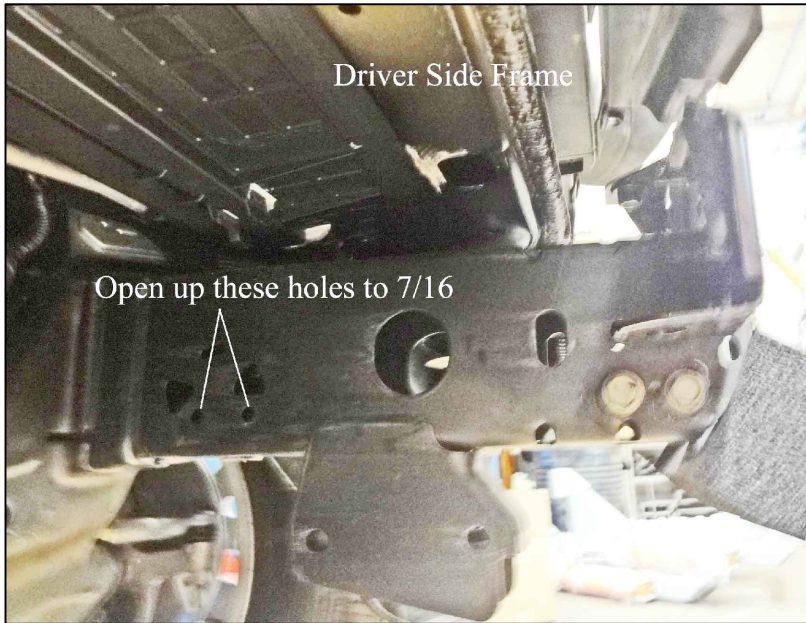

Driver Side Frame

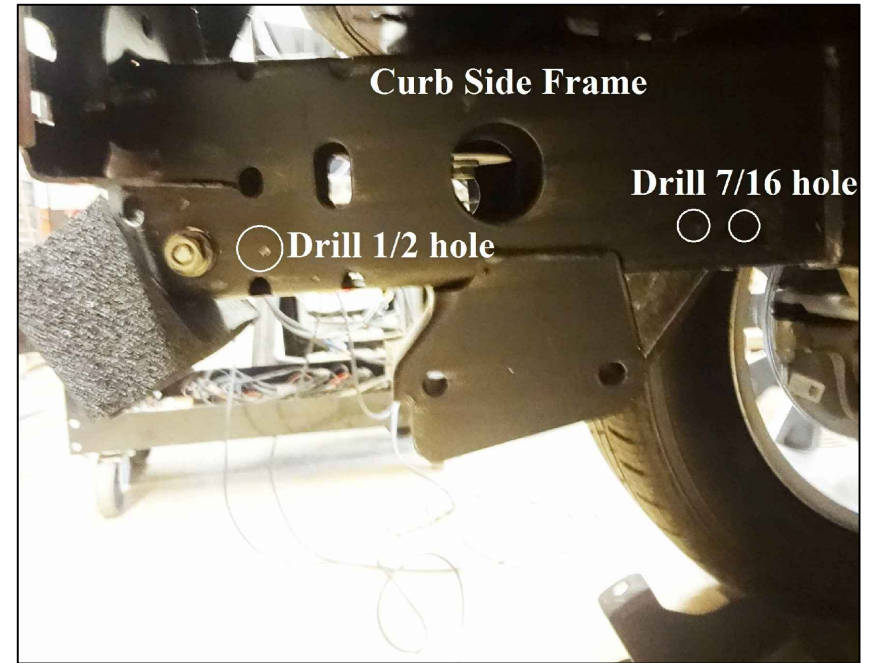

Passenger Side Frame

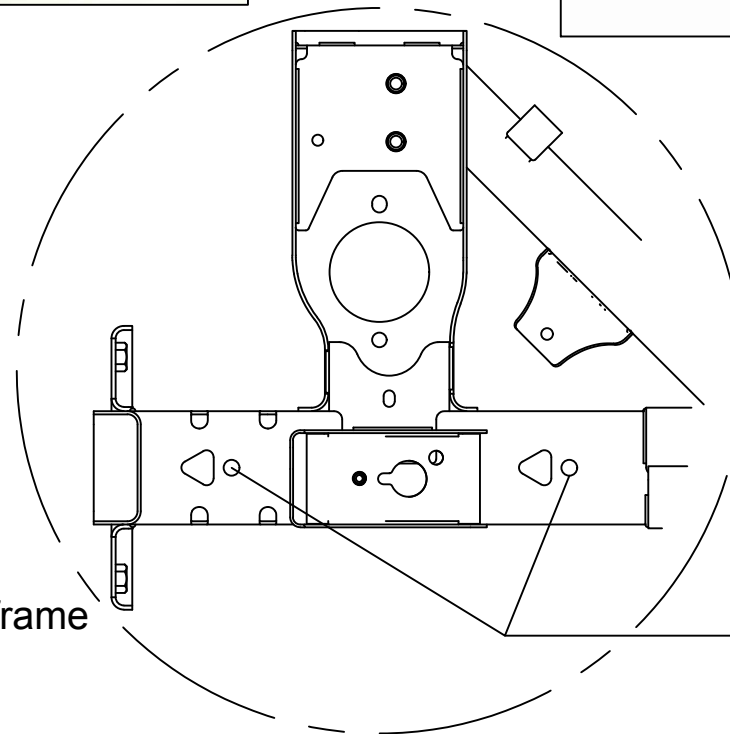

Use holes in the mounting bracket as guides to drill holes on vehicle frame

Use these two holes at bottom of the frame to mount the bracket (1)

53753-HOP			
Item	Part #	Description	Quantity
1	53761-D	HOP Mounting Bracket	1
2	53757-M	Inside Plate	4
3	52757-17-A	7/16 x1 1/2 UNF with 18" Handle	6
4	HH-00341-005	7/16" Flat washer	10
5	HH-00540-099	7/16-20 Nylon Insert	10
6	HH-00972-071	7/16-20x1.1/2 HHCS	4
7	HH-00972-090	1/2-20x1.1/2 HHCS	4
8	HH-00341-006	1/2" Flat Washer	4
9	HH-00457-001	1/2" Lock Washer	4
10	HH-00460-002	1/2"-20 Hex nut	4
11	HH-00972-153	3/4" x 3 1/2" UNF Cap Screw	1
12	HH-00973-007	3/4" UNF Thin Collar Lock nut	3
13	HH-00972-149	3/4" x 2 1/2" UNF Cap Screw	1
16	53661-D	Lift Frame Homeowner Plow	1
17	50069-C-GA	Lift Channel	1
18	HH-00972-155	3/4x4 UNF Cap Screw	1
19	52373-M	Jack Assembly	1
20	52757-M	Lift Channel Pin Assembly	1

Quick Link is a trademark of Arctic Equipment Manufacturing Corporation.

Installation Instructions

Before drilling any holes in the firewall or frame, move brake lines, fuel lines and/or electrical wiring from the path of the drill. Brake and fuel lines must also be clear of any fasteners. Do not under any circumstances disable, remove or relocate any sensors or other components related to the operation of the air bags.

General order of installation:

- install all components (mounting bracket, thrust arm and spreader bar) and all fasteners finger tight (snug) through existing holes,
- use removable grade LOCTITE #242 on all bolts,
- drill necessary holes and
- tighten all hardware.

After first use, re tighten all mounting bolts; thereafter check mounting bolt tightness periodically and at the start of the season.

Before proceeding, read instructions carefully and familiarize yourself with the components and hardware.

NOTE: It may be necessary, on some vehicles, to use a form of load booster to decrease the vehicle's front suspension sag when snowplows is attached to the vehicle. This can be done with the use of booster springs, supplementary air bags or similar load boosting devices. It is up to the customer to choose and purchase the product that suits this application.

Arctic Equipment Manufacturing reserves the right, under its product improvement policy, to change construction, design details or specifications without notice or without incurring any obligation.

1. Remove the front grille.
2. Remove the bumper by unfastening the bumper bolts (4 per side).
3. Remove the bottom skid plate. Return the parts to customer.



4. Remove the tow hooks and return to the customer.
5. On the driver side of the vehicle frame, open two back holes to 7/16 (shown on Page 3).

6. Jack the mounting bracket (1) up till the point the horizontal plates on mounting bracket are rested at the bottom of the vehicle frame. Adjust the mounting bracket (1) so that the holes are getting aligned with vehicle frame (shown on Page 3).
7. Insert 4 of the support plates (2) inside the vehicle frame (2 per side). Insert 4 of 7/16" x 1 1/2" (2 per side) through the support plate, 7/16" flat washer (4) and 7/16" hex nut (5).
8. On the driver side of the vehicle frame on the side at the back, install 2 of 7/16" bolts with 18" welded handle (3) along with flat washer (4) secured with nylon inserts (5).
At the front, install 7/16 x 1 1/2 bolt (6) with flat washer (4) and lock nut (5), same as 2 of 1/2 x 1 1/2 bolt (7), flat washers (8) lockwashers (9) and hex nut (10).
9. On the curb side of the vehicle frame at the front, install 7/16 x 1 1/2 bolt (6) with flat washer (4) and lock nut (5), same as 1/2 x 1 1/2 bolt (7), flat washer (8) lockwashers (9) and hex nut (10).
10. Before drilling holes in the curb side vehicle frame (refer to Page 3), be sure that mounting bracket is tight to the bottom of vehicle frame and all bolts are snug.
11. After drilling holes (one 1/2" hole at the front and two 7/16" bolts at the back) using the mounting bracket holes as a guide, insert the bolts following same procedure as on the driver side.
12. Torque all the fasteners as per the torque chart.
13. For Chevy truck, before reinstalling the bumper, make sure to cut the pastic piece to avoid interference with lift frame.

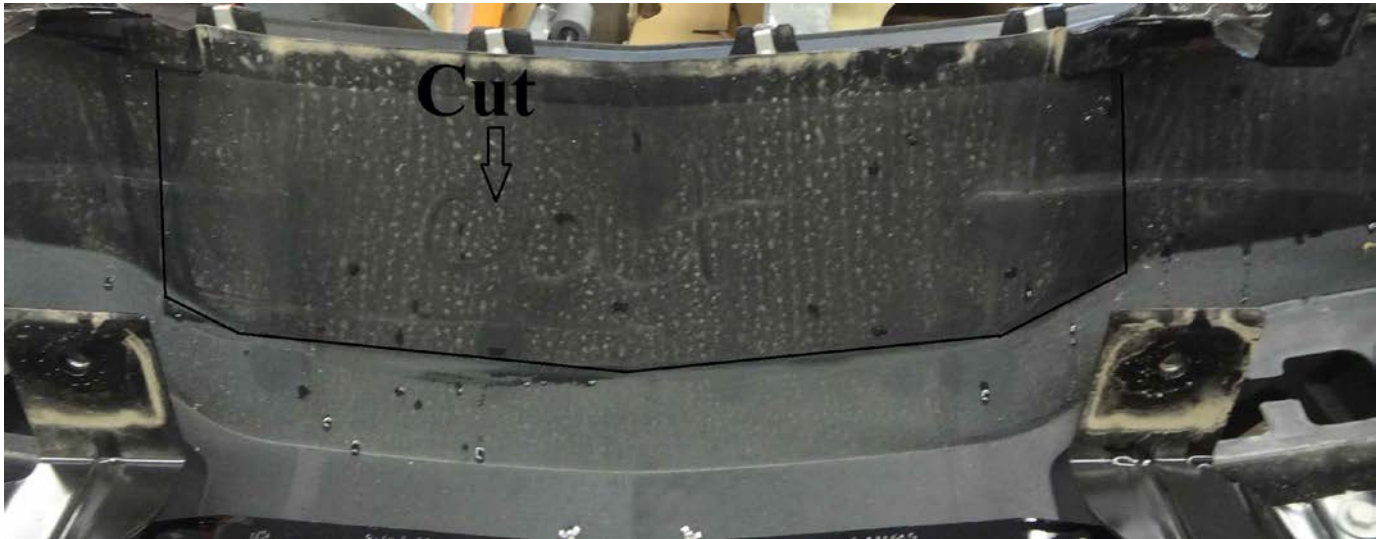

11. For GM truck, after removing the lower bumper valence, reinstall the bumper back as shown below.

12. Return any unused items to the customer so that the vehicle can be returned to its original condition if the snowplow is removed.

13. See separate installation instructions for the hydraulic power unit, wiring and controls.

Suggested torque value for bolts				
Thread Size	Grade 5		Grade 8	
	Dry (ft. lb)	Oiled (ft.lb)	Dry (ft. lb)	Oiled (ft.lb)
¼-20	8	6	12	9
¼-28	10	7	14	11
5/16-18	17	13	24	18
5/16-24	19	15	27	21
3/8-16	31	24	44	34
3/8-24	35	27	49	38
7/16-14	49	38	70	54
7/16-20	55	42	78	60
½-13	75	58	105	82
½-20	85	65	120	90
5/8-11	150	115	210	165
5/8-18	170	130	240	185
¾-10	270	205	375	290
¾-16	295	230	420	320
7/8-9	395	305	605	455
7/8-14	435	335	670	515
1-8	590	455	905	695
1-14	660	510	1030	785

Arctic Equipment Manufacturing Corporation reserves the right under its product improvement policy to change construction or design details and furnish equipment when so altered without reference to illustrations or specifications used herein.