

Mounting Kit -53776-MKPBX

GMC Canyon/ Colorado 4x4 2015-2020

For snowplow lights (2015-2020), this kit requires:
800084 or 800086 light kit.
800109-MPX light adapter for Front Installation

▲ Warning

Arctic Equipment Manufacturing Corporation (Arctic) does not assume liability for damage to your motor vehicle resulting from the attachment or use of an Arctic snowplow. The purchaser assumes all vehicle risk associated with the attachment and operation of this snowplow.

The Arctic snowplow you purchase must be used only on vehicles equipped with the manufacturer's snow plow preparation packages. Snow plowing without the original plow preparation package may damage your vehicle. The added weight may impair the operation and control of your vehicle. Snow plowing with a vehicle not recommended for that purpose by the manufacturer may void your new vehicle warranty. If your vehicle is not equipped with an original snow plow preparation package, additional equipment may be necessary before snow plowing. Please consult your vehicle and snowplow dealers prior to the purchase and installation of the snowplow. The installation of such parts however is not a full substitute for the original equipment snowplow preparation package.

The loaded vehicle, including all aftermarket accessories, the snowplow, passengers and cargo, must not exceed the gross vehicle weight ratings (GAWR), front gross axle weight rating (FGAWR) or rear gross axle weight rating (RGAWR) specified on the Safety Compliance Certification Label located in the driver's side door opening. It is the operator's responsibility to verify that these rating are not exceeded. The use of rear ballast weight may be required to prevent exceeding the front GAWR.

To determine the Gross Axle Weights for your vehicle, including all aftermarket accessories, the snowplow, passengers and cargo, take your loaded vehicle and the snowplow to a scale. With the snowplow attached, place the front wheels of the vehicle on the scale to get the front gross axle weight (FGAW). To get the rear gross axle weight (RGAW), place the back wheels of the vehicle on the scale.

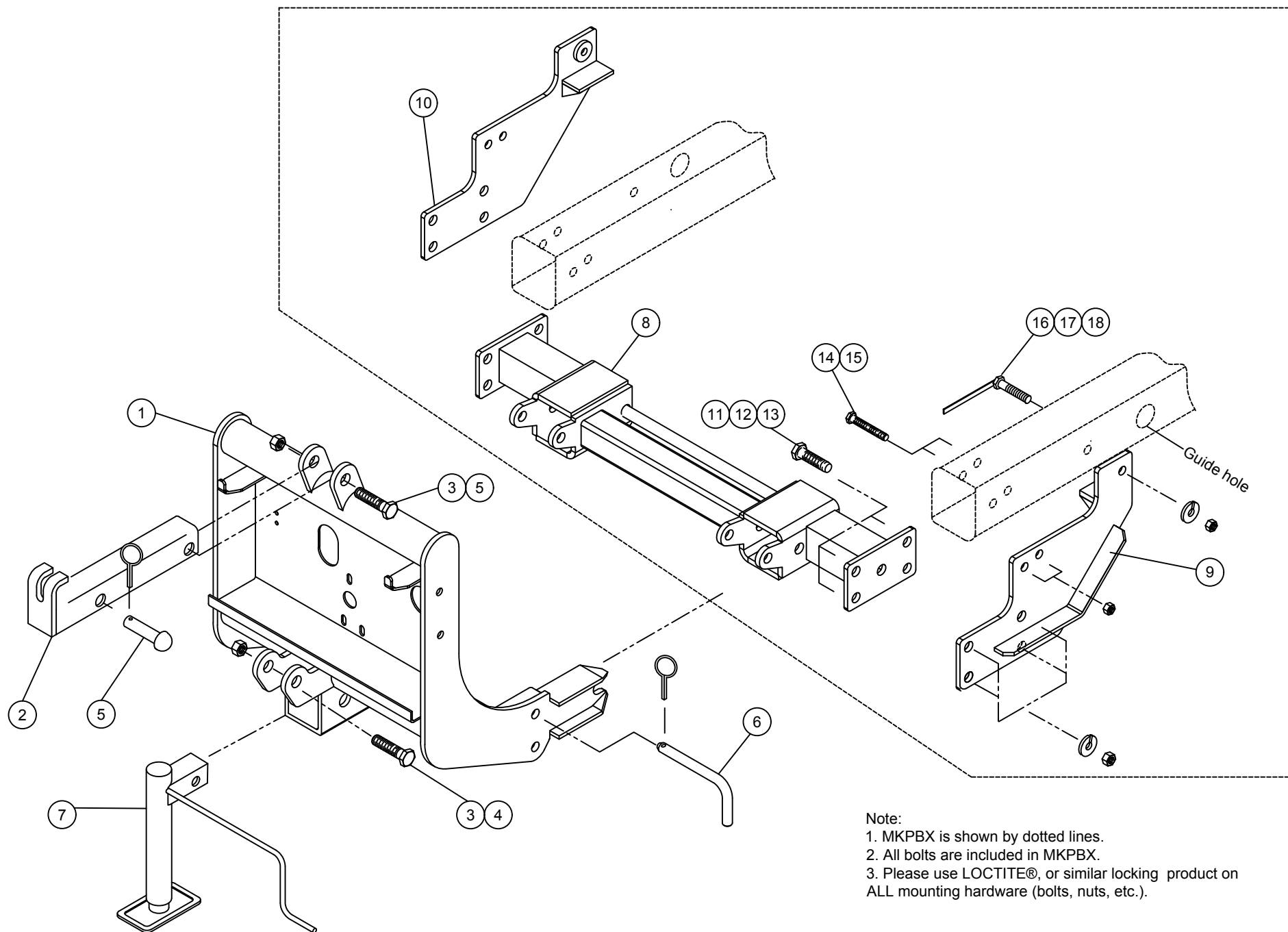

Note:
 1. MKPBX is shown by dotted lines.
 2. All bolts are included in MKPBX.
 3. Please use LOCTITE®, or similar locking product on ALL mounting hardware (bolts, nuts, etc.).

Item	Part #	Description	Quantity
1	53613-D	Lift Frame, XP Plow	1
2	50069-C-GA	Lift Channel (1.5" Cylinder)	1
3	HH-00972-153	3/4 x 3 1/2" UNF Cap Screw	2
4	HH-00973-007	3/4" UNF Lock nut	2
5	52757-M	Rivet Assy (rivet & lynch pin)	1
6	1302045	Pin Assembly	2
7	52373-M	Jack Assembly	1
8	53775-D	Spreader Bar	1
9	53774-01-D	Frame Bracket Driver Side	1
10	53774-02-D	Frame Bracket Curb Side	1
11	HH-00972-129	5/8-18 x 1 3/4 HHCS	8
12	HH-00457-003	5/8" Lockwasher	8
13	HH-00460-001	5/8-18 hex nut	8
14	HH-01169-100	1/2 - 20 x 4" Grade 8 HHCS	4
15	HH-011026-002	1/2 lock nut	4
16	HH-00457-001	1/2" lockwasher	2
17	HH-00460-002	1/2" - 20 hex nut	2
18	52941-01-A	1/2 x 1 1/4 Grade 8 bolt with welded handle	2

Quick Link is a trademark of Arctic Equipment Manufacturing Corporation.

Installation Instructions

Before drilling any holes in the firewall or frame, move brake lines, fuel lines and/or electrical wiring from the path of the drill. Brake and fuel lines must also be clear of any fasteners. Do not under any circumstances disable, remove or relocate any sensors or other components related to the operation of the air bags.

General order of installation:

- install all components (mounting bracket, thrust arm and spreader bar) and all fasteners finger tight (snug) through existing holes,
- use removable grade LOCTITE #242 on all bolts,
- drill necessary holes and
- tighten all hardware.

After first use, re tighten all mounting bolts; thereafter check mounting bolt tightness periodically and at the start of the season.

Before proceeding, read instructions carefully and familiarize yourself with the components and hardware.

NOTE: It may be necessary, on some vehicles, to use a form of load booster to decrease the vehicle's front suspension sag when snowplows is attached to the vehicle. This can be done with the use of booster springs, supplementary air bags or similar load boosting devices. It is up to the customer to choose and purchase the product that suits this application.

Arctic Equipment Manufacturing reserves the right, under its product improvement policy, to change construction, design details or specifications without notice or without incurring any obligation.

1. Remove the bumper inserts and bumper valence from the vehicle. Remove the lower bumper valence from bumper inserts.

2. Remove the bottom skid plate. Return parts to the customer.



3. Remove tow hook fasteners, leave tow hooks in this same position on the vehicle.

4. Position the frame bracket (9)(10) by aligning the top two holes on the bracket with holes of tow hook, make sure that the rear horizontal plate on the frame bracket rests on bottom of the vehicle frame.

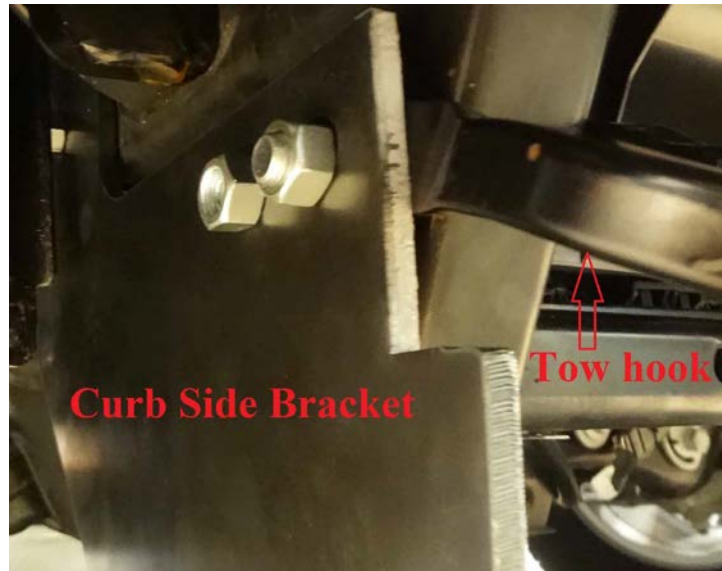

5. Insert $\frac{1}{2}$ x 4" bolt (14) through the tow hook and the frame bracket (9)(10) and secure it with $\frac{1}{2}$ " lock nut (15) (refer to the picture above). Do not tighten any bolts until instructed.

6. Using guide hole on the vehicle frame, insert $\frac{1}{2}$ bolt with welded handle (18) at the rear of frame bracket, secure with $\frac{1}{2}$ lockwasher (16) and hex nut (17) (see picture below).

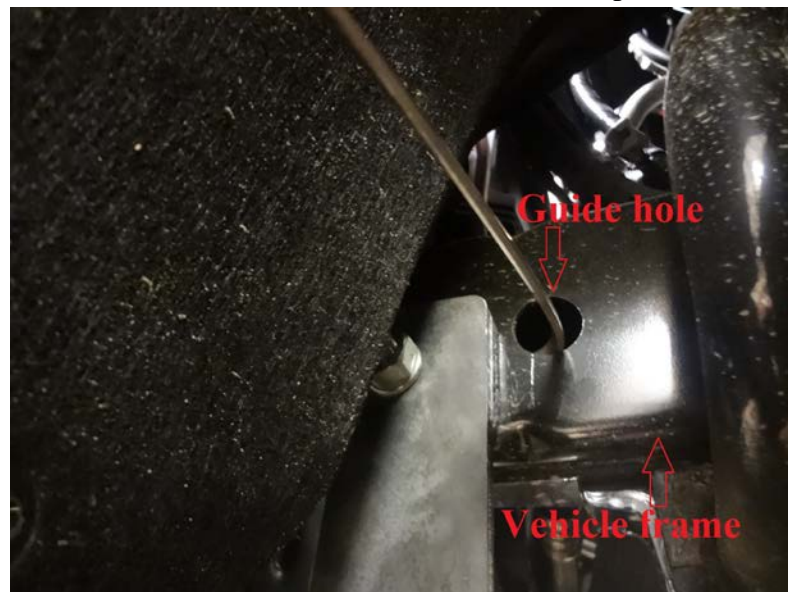

7. Jack the spreader up (8) to the point when four holes on the spreader bar align with the frame brackets (9)(10).

8. Insert $\frac{5}{8}$ x $1 \frac{3}{4}$ bolt (11) and secure it with $\frac{5}{8}$ lockwashers (12) and hex nut (13).

10. Torque all the fasteners as per the torque chart.
9. Return any unused items to the customer so that the vehicle can be returned to its original condition once the snowplow is removed.
10. See separate installation instructions for hydraulic power unit, wiring and controls.
11. Bumper inserts can be trimmed and installed back on the vehicle or can entirely be removed from the vehicle. See Picture below for trimming the bumper inserts.



Suggested torque value for bolts				
Thread Size	Grade 5		Grade 8	
	Dry (ft. lb)	Oiled (ft.lb)	Dry (ft. lb)	Oiled (ft.lb)
¼-20	8	6	12	9
¼-28	10	7	14	11
5/16-18	17	13	24	18
5/16-24	19	15	27	21
3/8-16	31	24	44	34
3/8-24	35	27	49	38
7/16-14	49	38	70	54
7/16-20	55	42	78	60
½-13	75	58	105	82
½-20	85	65	120	90
5/8-11	150	115	210	165
5/8-18	170	130	240	185
¾-10	270	205	375	290
¾-16	295	230	420	320
7/8-9	395	305	605	455
7/8-14	435	335	670	515
1-8	590	455	905	695
1-14	660	510	1030	785

Arctic Equipment Manufacturing Corporation reserves the right under its product improvement policy to change construction or design details and furnish equipment when so altered without reference to illustrations or specifications used herein.