

Mounting Kit 53791-MKPB-QLIV

K2500 Sierra/Silverado 4x4 2020
K3500 Sierra/Silverado 4x4 2020

For snowplow lights, this kit requires:
800084 or 800086 light kit.
800104-MPX light adapter for Front Installation

▲ Warning

Arctic Equipment Manufacturing Corporation (Arctic) does not assume liability for damage to your motor vehicle resulting from the attachment or use of an Arctic snowplow. The purchaser assumes all vehicle risk associated with the attachment and operation of this snowplow.

The Arctic snowplow you purchase must be used only on vehicles equipped with the manufacturer's snow plow preparation packages. Snow plowing without the original plow preparation package may damage your vehicle. The added weight may impair the operation and control of your vehicle. Snow plowing with a vehicle not recommended for that purpose by the manufacturer may void your new vehicle warranty. If your vehicle is not equipped with an original snow plow preparation package, additional equipment may be necessary before snow plowing. Please consult your vehicle and snowplow dealers prior to the purchase and installation of the snowplow. The installation of such parts however is not a full substitute for the original equipment snowplow preparation package.

The loaded vehicle, including all aftermarket accessories, the snowplow, passengers and cargo, must not exceed the gross vehicle weight ratings (GAWR), front gross axle weight rating (FGAWR) or rear gross axle weight rating (RGAWR) specified on the Safety Compliance Certification Label located in the driver's side door opening. It is the operator's responsibility to verify that these ratings are not exceeded. The use of rear ballast weight may be required to prevent exceeding the front GAWR.

To determine the Gross Axle Weights for your vehicle, including all aftermarket accessories, the snowplow, passengers and cargo, take your loaded vehicle and the snowplow to a scale. With the snowplow attached, place the front wheels of the vehicle on the scale to get the front gross axle weight (FGAW). To get the rear gross axle weight (RGAW), place the back wheels of the vehicle on the scale.

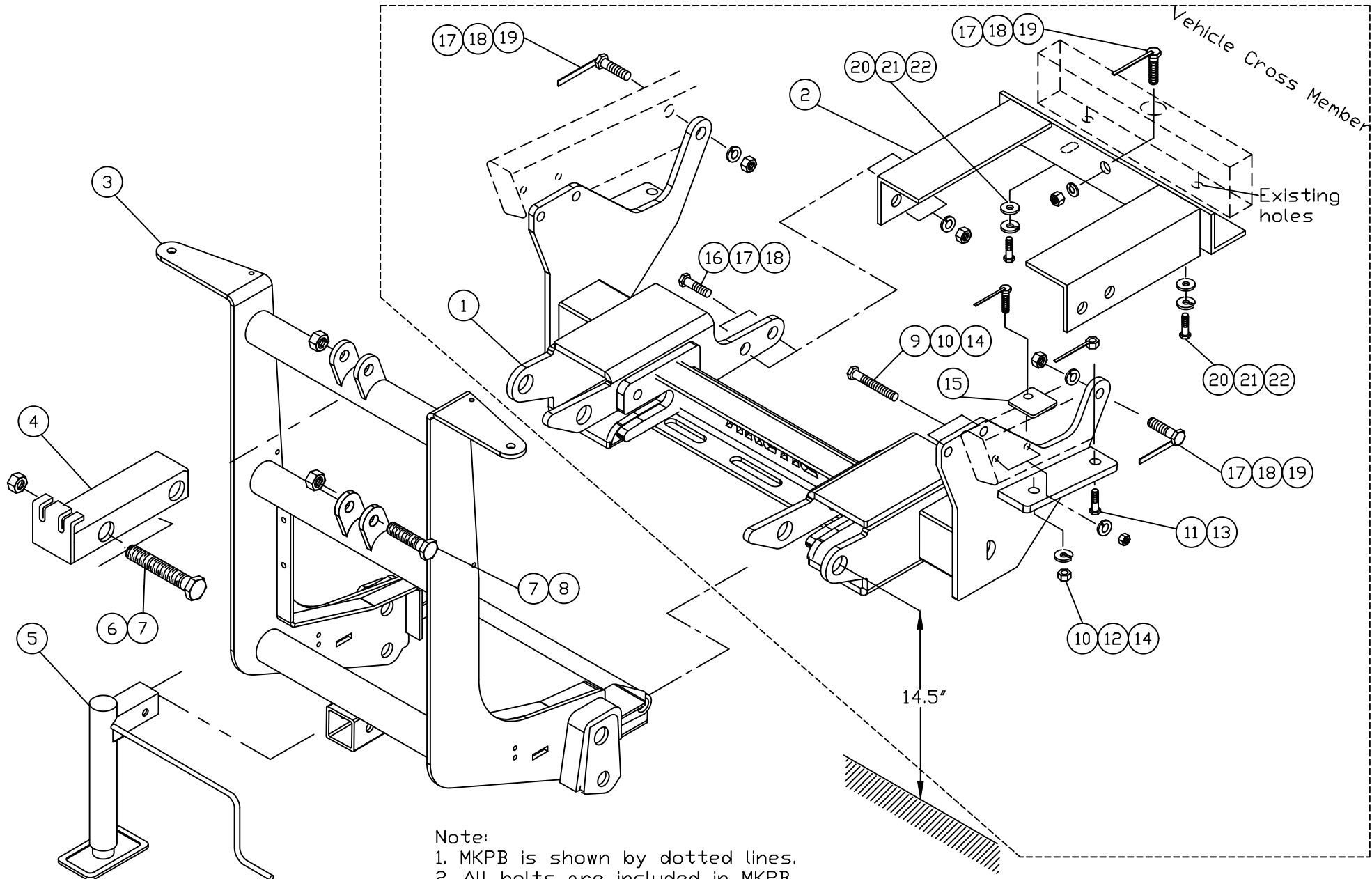

Note:
 1. MKPB is shown by dotted lines.
 2. All bolts are included in MKPB
 3. Use LOCTITE®, or similar locking product on ALL mounting hardware (bolts, nuts, etc.).

53791-MKPB-QLIV			
Item	Part #	Description	Quantity
1	53792-D	Mounting Bracket	1
2	53793-B	Thrust Arm	1
3	53517-D	QLIV Hi boy lift frame	1
4	52612-M-GA	Lift Channel (2" lift cylinder)	1
5	52373-M	Jack	1
6	HH-00972-155	3/4 x 4" UNF HHCS	1
7	HH-00973-007	3/4" Thin Collar Lock nut	3
8	HH-00972-15	3/4 x 3 1/2" UNF HHCS	2
9	HH-01169-102	1/2" x 4 1/2" UNF HHCS	4
10	HH-00457-001	1/2" Lockwasher	6
11	HH-00293-091	1/2 x 1 3/4" UNC HHCS	2
12	52575-A	1/2"-20 x 1 1/2" with 6" welded handle	2
13	52575-14-A	1/2" NC Flange nut with welded handle	2
14	HH-00460-002	1/2 -20 Hex nut	6
15	53797-A	Inside Frame Plate	2
16	HH-00972-129	5/8"-18 X 1 3/4" HHCS	4
17	HH-00460-001	5/8"-18 hex nut	7
18	HH-00457-003	5/8" Lockwasher	7
19	52575-11-A	5/8 x 1 1/2" with 18" welded handle	3
20	HH-00909-023	M10 x 45mm Grade 8.8 bolt	2
21	HH-00932-003	M10 Flatwasher	2
22	HH-00933-003	M10 Lockwasher	2

Quick Link is a trademark of Arctic Equipment Manufacturing Corporation.

Installation Instructions

Before drilling any holes in the firewall or frame, move brake lines, fuel lines and/or electrical wiring from the path of the drill. Brake and fuel lines must also be clear of any fasteners. Do not under any circumstances disable, remove or relocate any sensors or other components related to the operation of the air bags.

General order of installation:

- install all components (mounting bracket, thrust arm and spreader bar) and all fasteners finger tight (snug) through existing holes,
- use removable grade LOCTITE #242 on all bolts,
- drill necessary holes and
- tighten all hardware.

After first use, re tighten all mounting bolts; thereafter check mounting bolt tightness periodically and at the start of the season.

Before proceeding, read instructions carefully and familiarize yourself with the components and hardware.

NOTE: It may be necessary, on some vehicles, to use a form of load booster to decrease the vehicle's front suspension sag when snowplows is attached to the vehicle. This can be done with the use of booster springs, supplementary air bags or similar load boosting devices. It is up to the customer to choose and purchase the product that suits this application.

Arctic Equipment Manufacturing reserves the right, under its product improvement policy, to change construction, design details or specifications without notice or without incurring any obligation.

Installation Instructions:

1. On GMC, remove the bumper valence from the bumper, bumper removal is optional (Picture 1).

For Chevy, bumper removal is optional. Remove the bottom skirt from the bumper (Picture 2).



Picture 1



Picture 2

2. Remove the front bottom skid plate from the vehicle.(Picture 3).



Picture 3

3. Install thrust arms (2) in such a way that it gets sandwiched between the vehicle cross member and the rear bottom skid plate (Picture 4), using M10 x 45mm bolts (20), M10 lockwasher (21) and M10 flatwasher (22) .



Picture 4

4. Using 11/16" hole on thrust arm (2) as a guide, drill 11/16" hole on the vehicle cross member (be sure that thrust arm is tightly secured on the bottom to vehicle cross member). Insert 5/8" x 1 1/2" bolt with 18" handle (19) (cut handle as necessary) and secure it with 5/8 lockwasher (18) and 5/8 hex nut (17). (Do not tighten).

5. Loosen M10 bolts that is holding thrust arm (2) to the vehicle cross member.

6. Remove two front tow hook bolts on each side from the vehicle frame- do not remove tow hooks.

7. Install one piece mounting bracket (1) on the vehicle frame. Jack the mounting bracket (1) up until the bottom plate on the bracket (1) rest on bottom of the vehicle frame, also two front holes should line up with tow hook holes.

8. Insert two 1/2 x 4 1/2" (9) bolts (do not use vehicle fasteners) through the front tow hook holes on the vehicle frame and mounting bracket (1) (tow hook must be in) and secure them with 1/2" lock washer (10), 1/2 hex nut (14).

9. On driver side, at the back, install 5/8" x 1 1/2" bolt with 18" welded handle (19). Guide the bolt from front of vehicle frame all the way at the back hole of mounting bracket (1) and secure it with 5/8" lockwasher (18) and 5/8 hex nut (17).

On the Curb side, insert 5/8" x 1 1/2 bolt with 18" welded handle (19) (cut handle as necessary) (use a hole on the side of vehicle frame as access hole) and secure it with 5/8" lockwasher (18) and 5/8 hex nut (17).

10. Attach the mounting bracket (1) to the thrust arm (2) using 5/8 x 1 3/4" bolts (16) (two per side), 5/8" lockwasher (18) and 5/8" hex nut (17) (see drawing on Page #3).
11. Using 9/16" holes on bottom plate of mounting bracket (1) as guides, drill two 9/16" holes through the bottom of vehicle frame.
12. Insert the support plate (15) inside the vehicle frame and align with front drilled hole on vehicle frame, insert 1/2" x 1 1/2" bolt with 6" welded handle (12) going through the support plate, vehicle frame and mounting bracket and secure it with 1/2" lockwasher (10) and 1/2" hex nut (14).
12. At the back hole, guide the nut with welded handle (13) from front of vehicle frame and secure it with 1/2 x 1 3/4" bolt (11) from the bottom of vehicle frame.
13. Repeat the same procedure on curb side.
14. Torque all the fasteners according to the torque chart.
15. Return any unused items to the customer so that the vehicle can be returned to its original condition if the snowplow is removed.
16. See separate installation instructions for the hydraulic power unit, wiring and controls.

Suggested torque value for bolts				
Thread Size	Grade 5		Grade 8	
	Dry (ft. lb)	Oiled (ft.lb)	Dry (ft. lb)	Oiled (ft.lb)
¼-20	8	6	12	9
¼-28	10	7	14	11
5/16-18	17	13	24	18
5/16-24	19	15	27	21
3/8-16	31	24	44	34
3/8-24	35	27	49	38
7/16-14	49	38	70	54
7/16-20	55	42	78	60
½-13	75	58	105	82
½-20	85	65	120	90
5/8-11	150	115	210	165
5/8-18	170	130	240	185
¾-10	270	205	375	290
¾-16	295	230	420	320
7/8-9	395	305	605	455
7/8-14	435	335	670	515
1-8	590	455	905	695
1-14	660	510	1030	785

Arctic Equipment Manufacturing Corporation reserves the right under its product improvement policy to change construction or design details and furnish equipment when so altered without reference to illustrations or specifications used herein.