

Galvanized Electric Spreader

Models AG4E/AG6E/AG8E/AG10E

Warning:

Do not exceed GVWR or GAWR with spreader and load. Overloading could result in an accident or damage.

Read this manual before installing or operating the spreader.

Sander Warranty

ARCTIC salt/sanding equipment is guaranteed to be free from defects in material or workmanship under normal use and service for 1 (one) year after the date of purchase.

Arctic Equipment Manufacturing Corporation will replace or repair, at its election, without charge, any part which becomes defective within the period of time described above.

See specifications below what is not covered under warranty.

In no event shall Arctic Equipment Manufacturing Corporation be liable for claims for loss of use or consequential damages.

This warranty is made only to the original purchaser. There is no other warranty expressed, implied, or statutory.

All parts returned to us, transportation charges prepaid, must be accompanied with a "Return Goods Authorization" number, obtained from the factory. In order to reduce down-time, we will, on your request, send the parts required and you will be billed under the usual terms. A credit will be issued to your account when the parts, in our examination, prove to be defective.

Warranty does not cover:

Certain types of damage can occur, which cannot be attributed to defects in material and/or warranty, but rather as the owner's responsibility.

These conditions include, but are not limited to the following items. Damage resulting from:

- Paint or surface coating deterioration, parts such as, drive chain, conveyor chain, belts, controller keypad, bushings, stripped keyways or splines on external shafts, nuts and bolts or tightening nuts and bolts which are considered normal maintenance.
- Problems caused by failure to follow instructions and failure to maintain the product as described in the owner's manual.
- Damage resulting from rust, corrosion, freezing or overheating; failure to maintain proper fluid/lubrication levels, using other than recommended grade and type of lubrication, failure to retighten fasteners, chains and belts.
- Damage to the product that has been subject to misuse, neglect, accident, or improper installation (mounting), maintenance, care or storage.
- Repairs by an unauthorized person (dealer).
- Damage caused by parts not used in accordance with their intended purpose.
- Damage due to abrasion of wiring harnesses.
- Travel time incurred to and from dealers or suppliers, accommodations, meals, cost of tax, freight to/from dealers, storage charges, environmental charges, solvents, sealants, lubricants.
- Problems caused by accessories and parts that are not supplied by Arctic Equipment.
- Liability for damage to the property, or injury to, or death of any person arising out of the operation, maintenance or use of the covered product.

The customer can register their equipment through Arctic website
<http://www.arcticsnowplows.com/warranty> .

Arctic Equipment Manufacturing Corporation reserves the right to change specification without prior notice.

Customer Responsibility

The loaded vehicle, including all after market accessories, the salt/sanding equipment, passengers, and cargo, **MUST NOT** exceed the gross vehicle weight ratings (GVWR), front gross axle weight rating (FGAWR) or rear gross axle weight rating (RGAWR) specified on the Safety Compliance Certification Label located in the driver's side door opening. **It is the operator's responsibility to verify that these ratings are not exceeded.**

To determine the Gross Axle Weights for your vehicle, including all after market accessories, the salt/sanding equipment, passengers, and cargo, take your loaded vehicle to a scale. Place the front wheels of the vehicle on the scale to get the Front Gross Axle Weights (FGAW). To get the Rear Gross Axle Weights (RGAW), place the back wheels of the vehicle on the scale.

Disclaimer notice

Arctic Equipment Manufacturing Corporation (Arctic) does not assume liability for damage to your motor vehicle resulting from the attachment or use of Arctic salt/sanding equipment. The purchaser assumes all vehicle risk associated with the attachment and operation of this salt/sanding equipment.

The added weight may impair the operation and control of your vehicle. Additional equipment may be necessary before installing salt/sanding equipment. Please consult your vehicle dealers prior to the purchase and installation of the salt/sanding equipment.

Electric Galvanized Spreader

WARNING:

- Do not exceed the gross vehicle weight ratings (GVWR), front gross axle weight rating (FGAWR) or rear gross axle weight rating (RGAWR) with spreader and load. Overloading could result in an accident or damage.(Refer to Material Density chart below)

Material Density (lb per cubic yd)

Fine Salt – Dry 1400

Coarse Salt – Dry 1300

Coarse Sand – Dry 2800

Coarse Sand – Wet 3300

For Electric sander with the variable speed box:

- Never hook booster cables directly to the motor; this would void your warranty.
- Unplug sander battery cables before boosting your truck.

Before attempting any procedure in this book, read and understand all the safety information contained in this section. In addition, ensure all individuals working with you are also familiar with these safety precautions.

For your safety, warning and information decals have been placed on this product to remind the operator to take safety precautions. It is important that these decals are in place and are legible before operation begins. New decals can be obtained from Arctic Equipment Manufacturing or your local dealer.

Remember it is the owner's responsibility for communicating information on the safe use and proper maintenance of this equipment. The careful operator is the best operator. Most accidents are caused by human error. Certain precautions must be observed to prevent the possibility of injury to operator or bystanders and/or damage to equipment.

- Driver to keep bystanders a minimum of 25 feet away from operating spreader.
- Servicing the sander without special tools and knowledge could result in personal injury. See an authorized Arctic dealer for service.
- Before servicing the spreader, wait for conveyor or spinner to stop and then lock out power.
- Do not climb into or ride on spreader.
- Disconnect electric and/or hydraulic power and tag out if required before servicing or performing maintenance.
- Do not allow hands, hair or clothing to get near any moving parts such as spinner, chain etc.
- Do not wear neckties or loose clothing when working on the vehicle. These things can catch on moving parts or cause an electrical short circuit that could result in personal injury. Do not wear wrist watches, rings or other jewellery when working on the vehicle or individual equipment
- Do not allow unauthorized person to operate this unit.
- Do not work on a vehicle without having a fully serviced fire extinguisher available. (Dry chemical unit specified for gasoline, chemical or electrical fires).
- Do not smoke while working on the vehicle. Gasoline and battery acid vapours are extremely flammable and explosive.
- Do not alter the sander, or any part without written approval of Arctic Equipment Manufacturing Corporation.
- Do not use your hands to search for hydraulic fluid leaks; escaping fluid under pressure can be invisible and can penetrate the skin and cause injury.
- Do not leave unused material in hopper. Material can freeze or solidify, causing unit to not work properly. Empty and clean after each use.
- Inspect the sander periodically for defects. Parts that are loose, broken, missing or plainly worn must be tightened or replaced immediately.
- Check the job site for terrain hazards, obstructions and people. Check surrounding area for hazardous obstacles before operating this unit.

- Wear safety goggles when working on the vehicle to protect your eyes from battery acid, gasoline, and dust or dirt from flying off of moving engine parts.
- Be aware of and avoid contact with hot surfaces such as engine, radiator, and hoses.
- Wear safety glasses with side shields when striking metal against metal. Failure to heed could result in injury to the eye(s) or other parts of the body.
- Shut off the vehicle engine, place the transmission in neutral or park, turn the ignition switch to the “off” position, firmly apply the parking brake of the vehicle before removing / installing the sander.
- Be sure that the sander is properly attached before moving the vehicle.
- To remove the sander, the unit must be empty. Do not stand close to the sander when it is being lifted. Keep a safe distance away.

Sander Specification

3/4HP electric motor, 55 amp electric motor.

In cab variable speed controller or On/Off toggle switch.

Variable Speed Controller for Electric Spreader is used for precise spreading. See more information in Variable Speed Control Section.

ON/ OFF switch - When a switch handle is in OFF position, a switch handle is not illuminated. If spreader in ON (motor is on) switch handle is illuminated red. If switch handle is illuminated white in OFF position a solenoid (under hood) is stuck and motor is running constantly. Disconnect power by removing connectors that connect two red and black cables at the back of the truck. See authorized Arctic Dealer.

The motor and drive system is protected by a hinged hood.

Quiet electric-drive system.

Low-maintenance.

Stainless steel drive chain and hardened sprockets.

Electric sander is equipped with an adjustable sand discharge chute. You can vary the spread width by simply redirecting the sand to another part of the spinner.

Spreader Installation

The AG6E spreader is designed for installation in a 6'/8' pickup truck bed. The AG8E is designed for installation in an 8' pickup truck bed. The AG10E spreader is designed for 10' dump truck or flat deck truck. Follow the steps below to install your unit in your vehicle.

- a) Slide spreader into position and secure with the ratchet straps into the cargo tie downs of the truck (pictures # 3 and #4)
- b) Bolt mounting angle bracket to spreader, then bolt it to the back of the truck using ½" bolt. (Picture #2)
- c) Install the sand chute using the required pivoting/fastening components. (Picture #12)
- d) Assemble the spinner assembly (split shafts), as shown in the assembly drawing in this manual, using the appropriate components. (Picture #5, 11 and 12)
- e) You may change the spinner disc height. Using the hole in the spinner disc hub as a guide, drill a hole through the shaft, for the mounting bolt. Cut off any excess length from the shaft and install the spinner disc.
- f) Connect all the cables as shown in the electric system diagram. Be sure to grease all connections.

Maintenance

Daily Inspection and Lubrication

- a) Check gearbox oil level. It should be filled to the oil level plug. (Picture#1)
- b) Lubricate the following grease nipples:
 - 1) 1 on conveyor idler shaft bearing (2 bearings) (picture #8)
 - 2) 1 on drive shaft bearing (picture #7)
 - 3) 1 on spinner shaft bearing (2 bearings if one hydraulic motor is used, 1 bearing if two hydraulic motors are used) (Picture #11)
 - 4) 1 on each coupling split shaft and gear box coupling (pictures #5 and #6)

Yearly Inspection

- a) At the end of the operating season, the unit should be thoroughly cleaned and lubricated. The conveyor chain (picture #9) should, ideally, be stored in oil. These preventative measures should prevent premature rusting of the unit. Grease bolts on the chain tightener's. (Picture #8)
- b) At this time or before the start of the next season, it is wise to check all drive components for appreciable wear. Any components which are questionable should be replaced now. This short and simple check will avoid down time during the operating season.

- c) Change the gear box oil.
- d) Replace the oil filter. (Note: If the unit is utilized year round, replace it twice a year).

Before Operating

- a) Grease all lubrication points.
- b) Ensure that the conveyor chain is dragging for one foot on the bottom return channel, of the spreader. (Do not over tighten the chain).

Lubricants

Speed Reducer Lubricant.....80W90 Gear lube

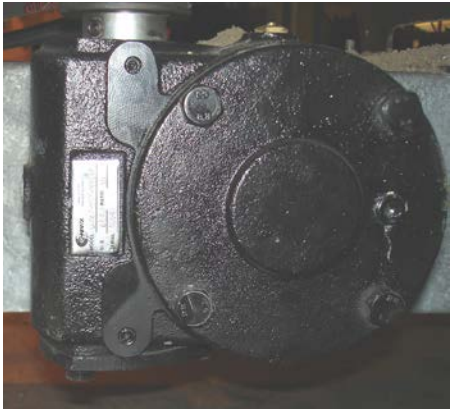

Picture #1



Picture #2



Picture #3



Picture #4



Picture #5



Picture #6



Picture #7



Picture #8



Picture #9



Picture #10



Picture #11



Picture #12

Troubleshooting of the Wireless Controller

It is important to know that the in-cab remote control and the controller on the spreader communicate with RF signals. Therefore, they are in constant communication with one another. This type of communication allows you to get instant info on your setting and it will also inform you on any problems that could happen during the use of your spreader.

Never hook booster cables directly to the motor; this would void your warranty.

Unplug sander battery cables before boosting your truck.

Problems:

- When the screen on the remote shows “O” it means that the system is in OVERLOAD

An overload of the system can be caused by:

- Frozen material inside the hopper.
- Accumulation of material in front and under the spreader
- Bearing starting to seize
- Worn-out conveyor chain
- Accumulation of material between the floor of the spreader and the drive sprockets.
- Battery in bad condition
- Controller poorly installed

- When the “O” is constantly rotating, this means, there is no communication (loss of signal) between the remote control and the control box. The spreader will automatically shut off.

By turning the main switch off and then turning it back on, the signal should come back. If the signal doesn't come back you can connect the remote directly to the black box by using the appropriate connectors on the controller. This operation will reset the system. If the problem persists here are some possibilities:

- Power is not going to the controller (black box)
- Check fuses (5 amp and 80 amp)/ Breaker engaged (if applicable)
- Bad connections
- Electrical noises or interferences
- Poorly installed controller

Programming

If you install new controller or if there is the “O” is constantly rotating, program the controller following this instruction. On/Off switch must be in ON position. Hold AUX or SYNC button on the controller before plugging in. Plug the controller in, “O” should stay on (that means the controller is programmed).

Wiring Diagram for Electric Sander with On/Off Switch

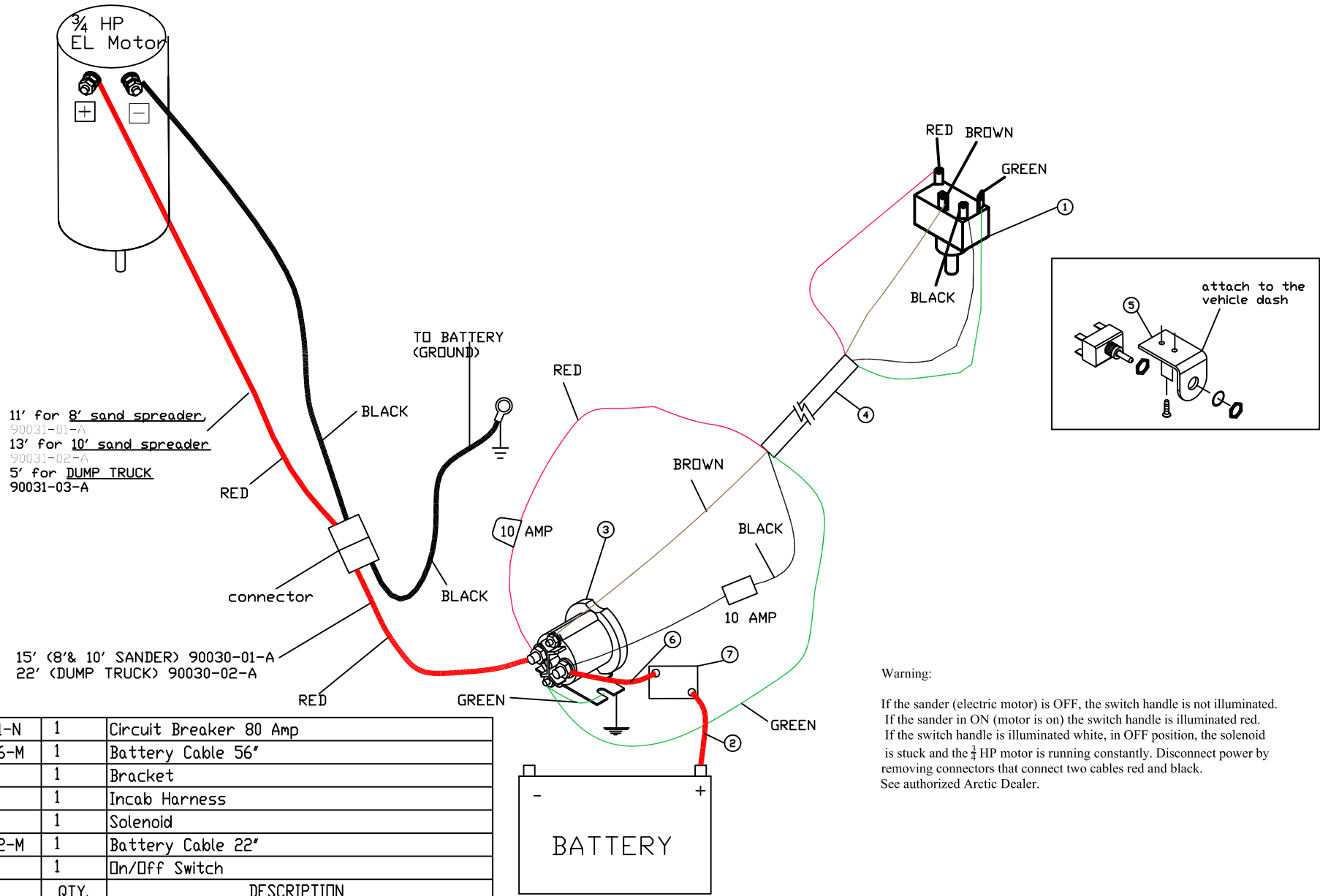

Warning:

If the sander (electric motor) is OFF, the switch handle is not illuminated.
 If the sander in ON (motor is on) the switch handle is illuminated red.
 If the switch handle is illuminated white, in OFF position, the solenoid is stuck and the 3/4 HP motor is running constantly. Disconnect power by removing connectors that connect two cables red and black.
 See authorized Arctic Dealer.

7	53608-01-N	1	Circuit Breaker 80 Amp
6	51335-56-M	1	Battery Cable 56"
5	52018-M	1	Bracket
4	90192-B	1	Incab Harness
3	90190-N	1	Solenoid
2	51335-22-M	1	Battery Cable 22"
1	90191-N	1	On/Off Switch
	PART #	QTY.	DESCRIPTION

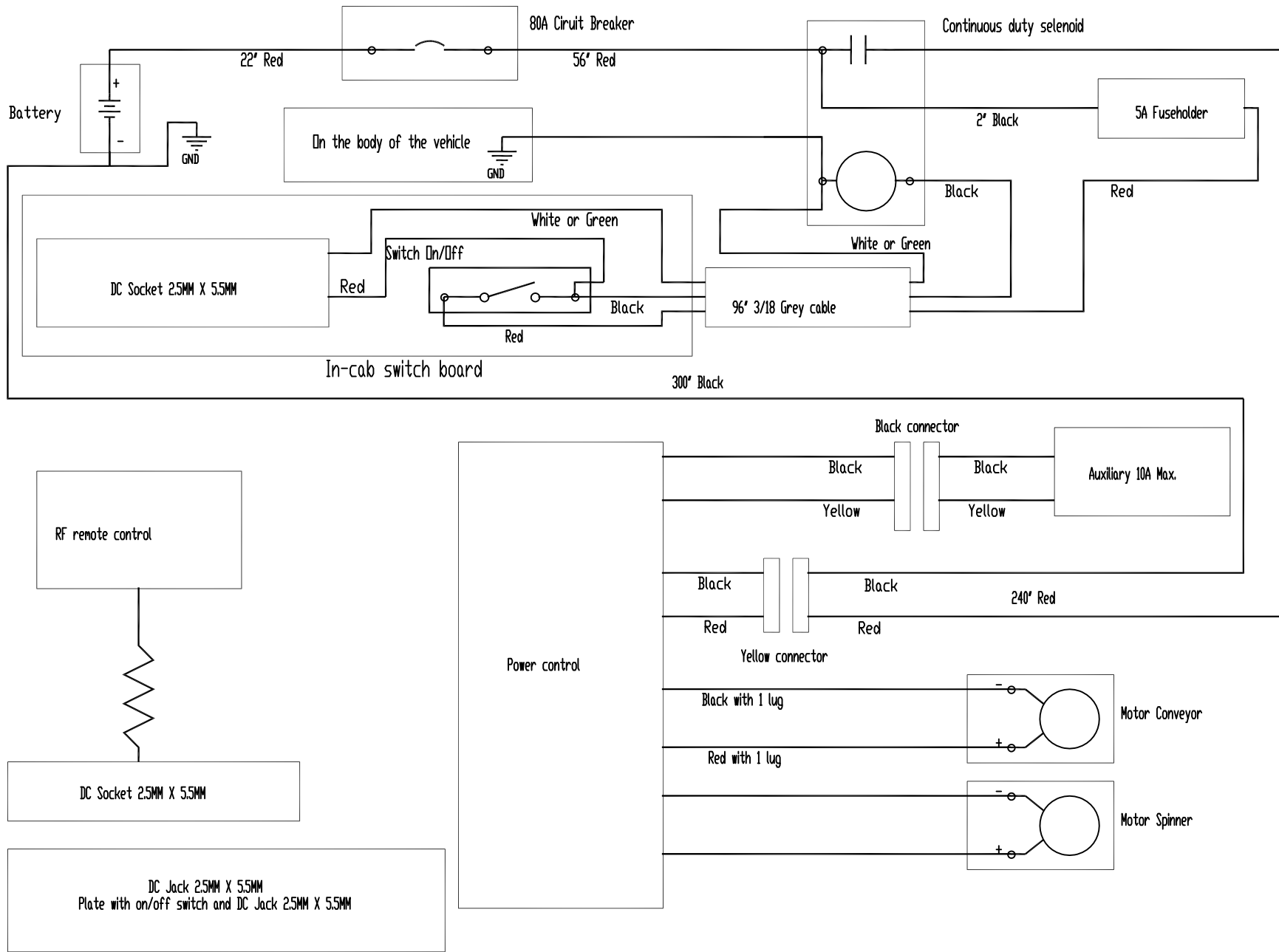

EQVSC-4/6/8-D & EQVSC-10-D Variable Speed Dual Electric Control Kit (Prior 2017)			
	Part #	Description	Quantity
1	90305-M	Dual Variable Speed Kit (include box and controller)	1
2	HH-00340-002	7/16-14 Lock nut	4
3	HH-00293-072	7/16-14 x 1.3/4 HHCS	4
4	HH-00020-081	1/8" x 3/4" Cotter Pin	1
5	90040-N	Sander Ratchet Strap	4
6	HH-00293-028	5/16-18x1 HHCS	3
7	HH-00341-003	5/16 Flatwasher	3
8	HH-00340-017	5/16-18 Lock nut	3
9	HH-01081-054	3/8-16 x 2.1/2 Grade	2
10	HH-00340-001	3/8-16 Lock Nut	2
11	HH-00789-00314	3/16 14" Chain	1
12	51335-22-M	Battery Cable 22"	1
12a	53608-01-N	Circuit Breaker 80 amp	1
12b	51335-56-M	Battery Cable 56"	1
13	HH-00972-090	1/2-20x1.1/2 HHCS	4
14	HH-00540-004	1/2-20 Lock Nut	4
15	HH-00455-007	#8x3/4 screw	2
16	90190-N	Solenoid	1
17	90306-B	Spinner Shaft (dual motor only)	1
18	HH-00013-073	#8-32x5/8 screw	4
19	HH-00340-019	#8-32 Hug Locknut	4
20	90307-N	Gear Motor	1
21	HH-00905-013	Spinner Bearing	2
22	HH-00017-024	1/4-20x1/4 set screw	2
23	90229-N	Salter Plate Light	1
24	53207-N	License Plate Plastic Nut	2
25	761232	Butt Connector	1
26	768222-048	Brown Wire 48", 14 g	1
27	769977-03	1/4" x 3" Shrink Tube	1
28	90030-VSC	Power Cable, Cab Section (for EQVSC-10-D only)	1
28a	90030-VSC-6/8	Power Cable, Cab Section (for EQVSC-6/8-D only)	1
29	HH-00909-003	M6x20mm hex bolt	4
30	HH-00932-001	M6 Flat Washer	4
31	HH-00933-001	M6 Lock Washer	4
32	90308-A	4" Ground Wire	1
33	HH-00455-007	#8 Self tapping Screw	2
34	90309-A	Gray Power wire c/w switch	1
35	EQTCVSCD	Wireless Control Dual motor	1

Wiring Diagram for Dual Wireless Variable Speed Control Box

2017 and After

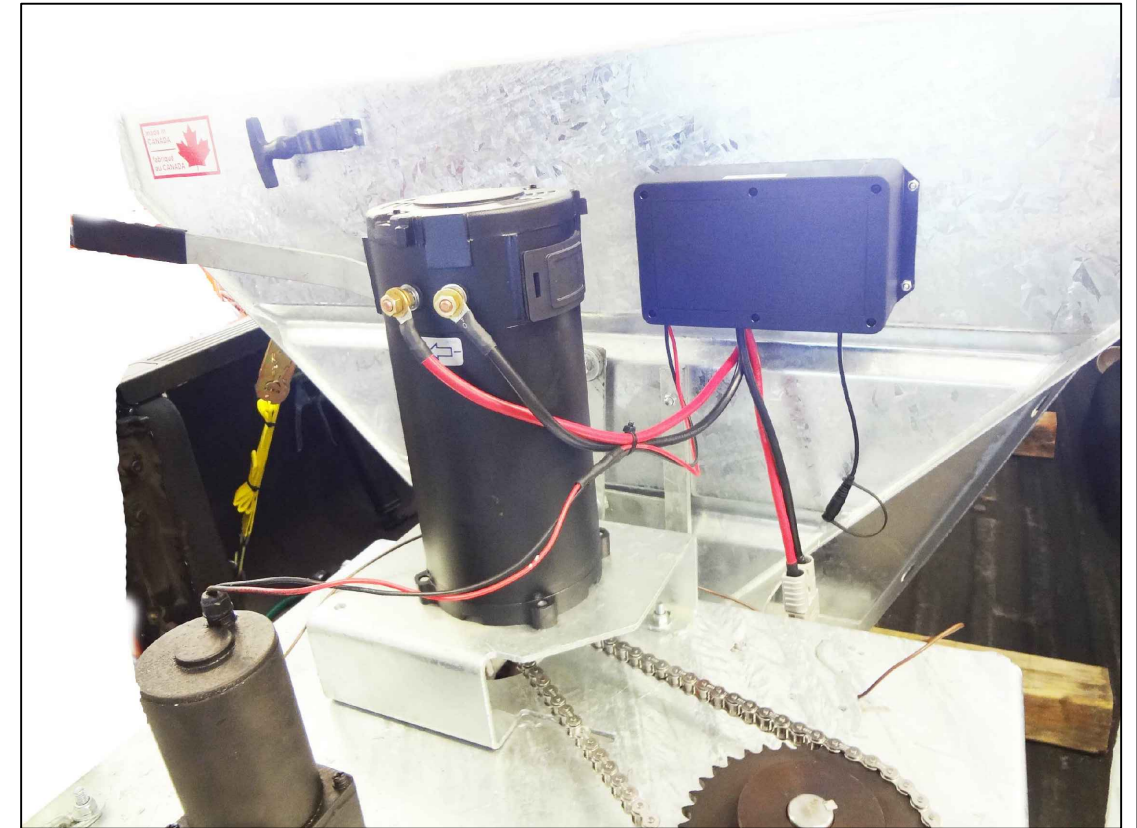
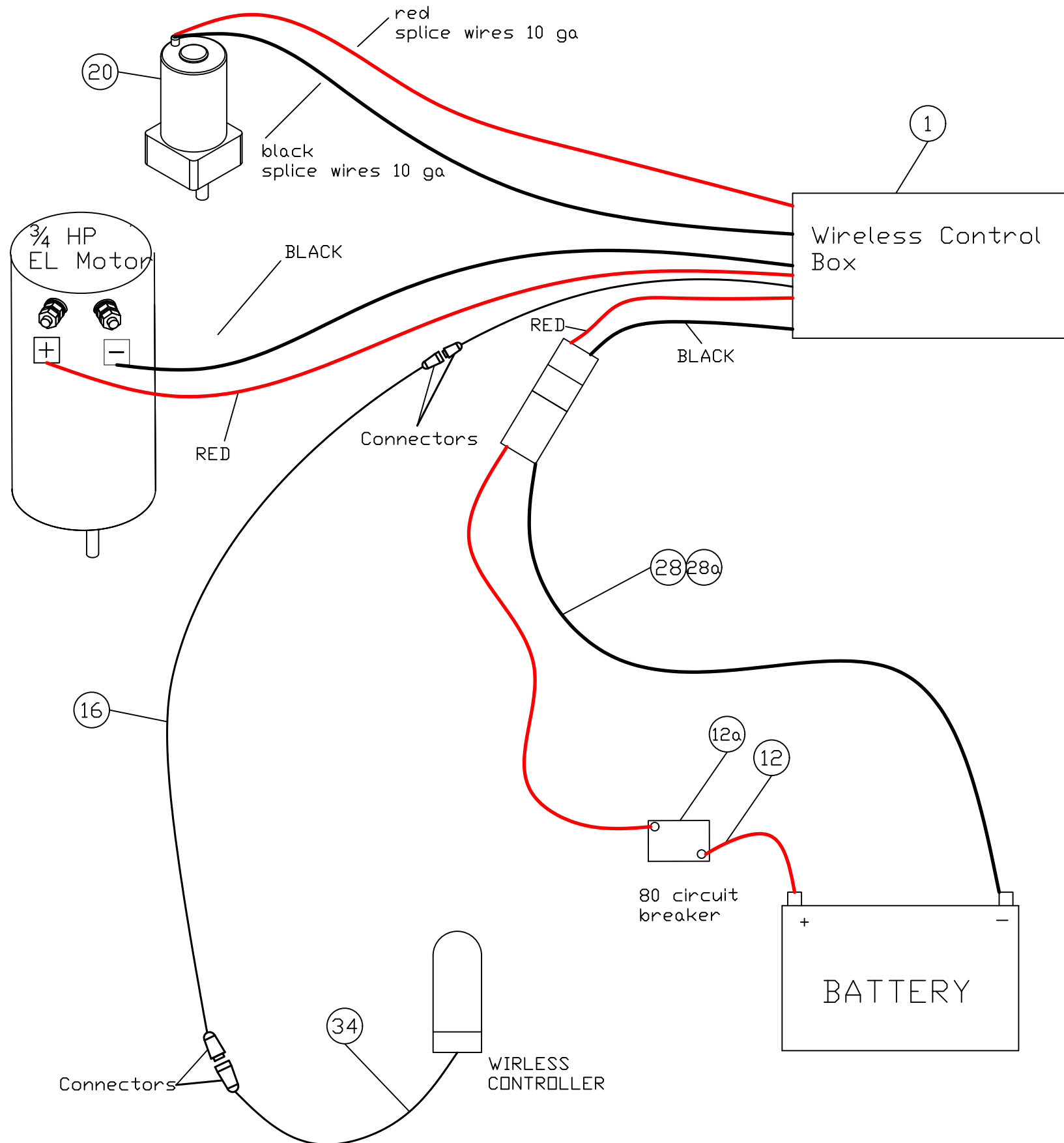

EQVSC-4/6/8-D & EQVSC-10-D Variable Speed Dual Electric Control Kit (2017 and After)			
	Part #	Description	Quantity
1	EQVSCDW-A	Dual Variable Speed Kit (include box and controller)	1
2	HH-00340-002	7/16-14 Lock nut	4
3	HH-00293-072	7/16-14 x 1.3/4 HHCS	4
4	HH-00020-081	1/8" x 3/4" Cotter Pin	1
5	90040-N	Sander Ratchet Strap	4
6	HH-00293-028	5/16-18x1 HHCS	3
7	HH-00341-003	5/16 Flatwasher	3
8	HH-00340-017	5/16-18 Lock nut	3
9	HH-01081-054	3/8-16 x 2.1/2 Grade	2
10	HH-00340-001	3/8-16 Lock Nut	2
11	HH-00789-00314	3/16 14" Chain	1
12	51335-56-M	Battery Cable 56"	1
12a	53608-01-N	Circuit Breaker 80 amp	1
13	HH-00972-090	1/2-20x1.1/2 HHCS	4
14	HH-00540-004	1/2-20 Lock Nut	4
15	HH-00455-007	#8x3/4 screw	2
16	EQC300JP	Wire for Remote Controller (25")	1
17	90306-B	Spinner Shaft (dual motor only)	1
18	HH-00013-073	#8-32x5/8 screw	4
19	HH-00340-019	#8-32 Hug Locknut	4
20	90307-N	Gear Motor	1
21	HH-00905-013	Spinner Bearing	2
22	HH-00017-024	1/4-20x1/4 set screw	2
23	90229-N	Salter Plate Light	1
24	53207-N	License Plate Plastic Nut	2
28	90030-VSC	Power Cable, Cab Section (for EQVSC-10-D only)	1
28a	90030-VSC-6/8	Power Cable, Cab Section (for EQVSC-6/8-D only)	1
29	HH-00909-003	M6x20mm hex bolt	4
30	HH-00932-001	M6 Flat Washer	4
31	HH-00933-001	M6 Lock Washer	4
33	HH-00455-007	#8 Self tapping Screw	2

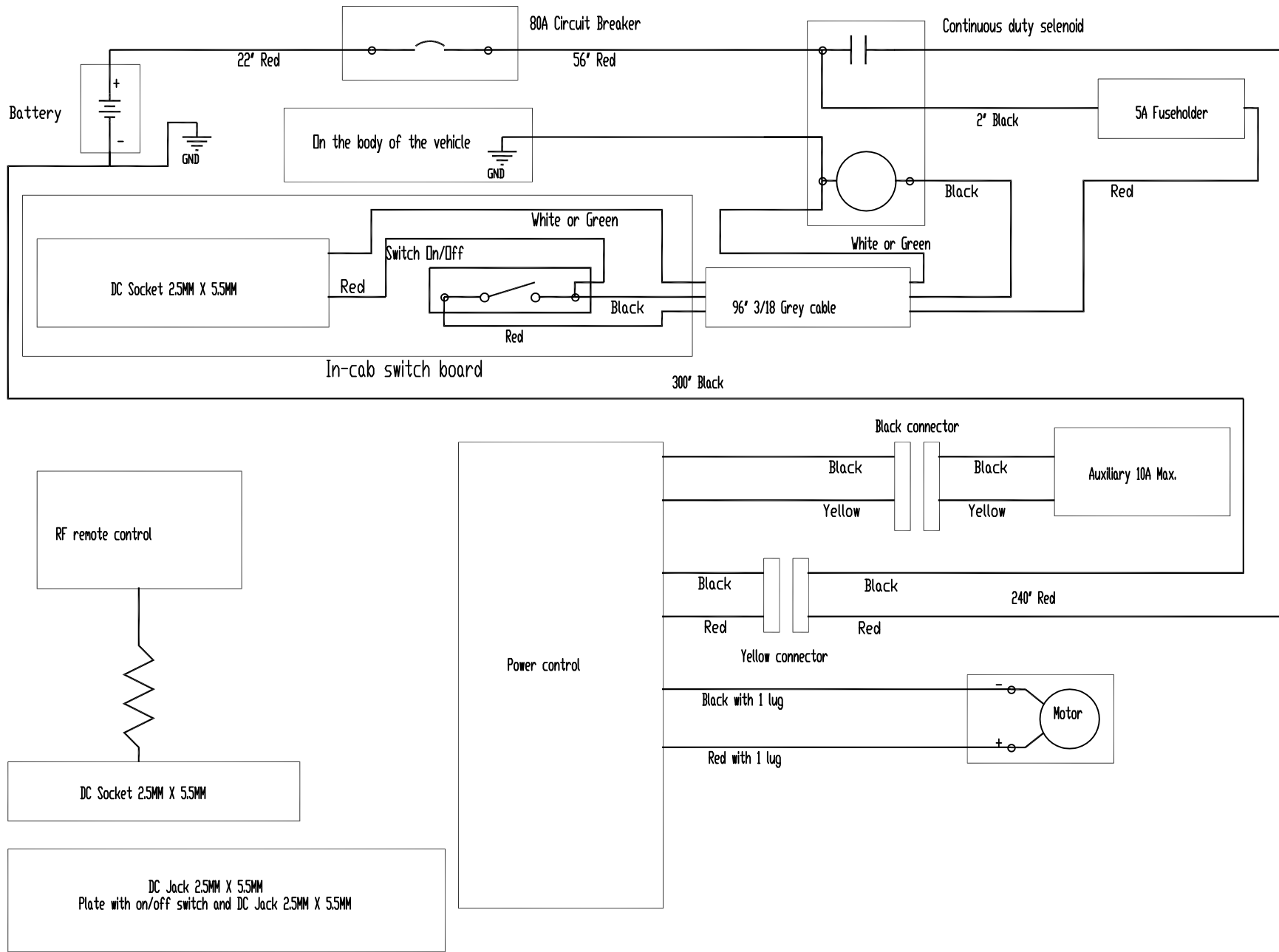

Wiring Diagram for Wireless Variable Speed Control Box

Prior 2017

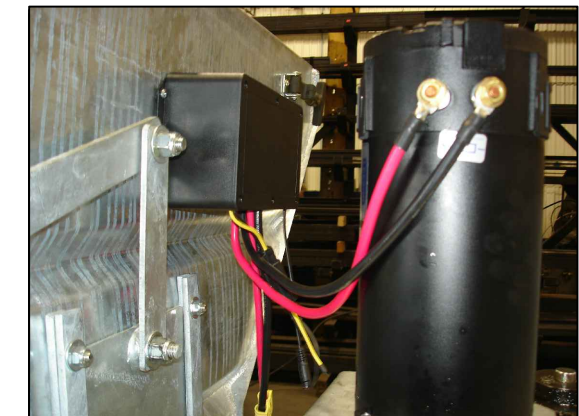
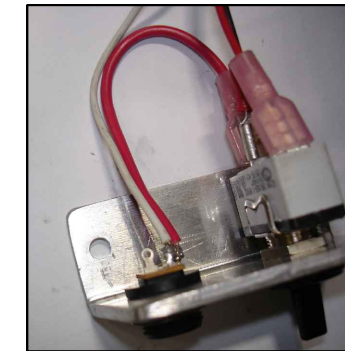
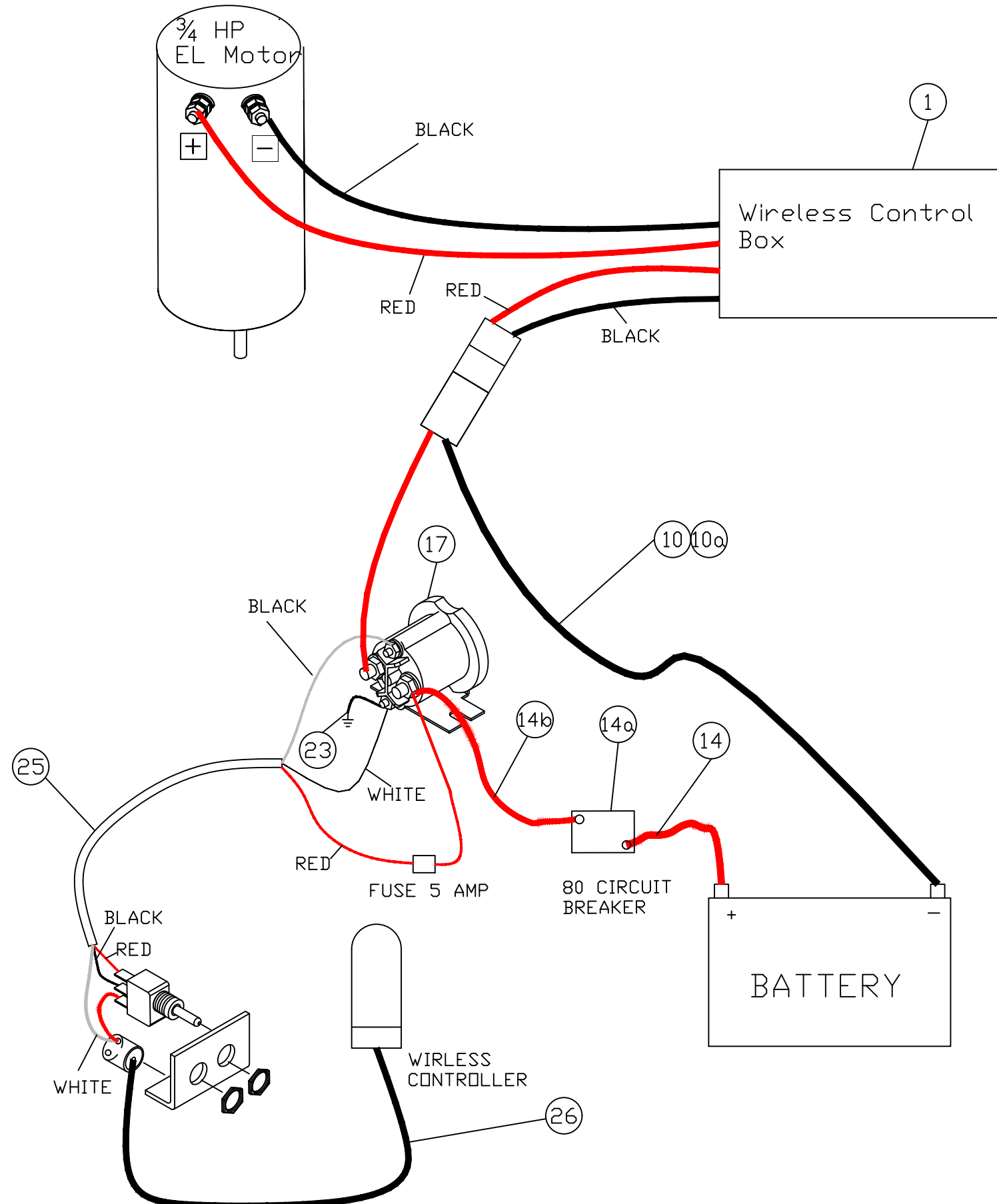

EQVSC-4/6/8 & EQVSC-10 Variable Speed Electric Control Kit (Prior 2017)			
	Part #	Description	Quantity
1	90304-M	Variable Speed Control Kit (include box and controller)	1
2	HH-00020-081	1/8" x 3/4" Cotter Pin	1
3	90040-N	Sander Ratchet Strap	4
4	HH-00293-028	5/16-18 x 1 HHCS	3
5	HH-00341-003	5/16 Flatwasher	3
6	HH-00340-017	5/16-18 Lock nut	3
7	HH-01081-054	3/8-16 x 2.1/2 Grade	2
8	HH-00340-001	3/8-16 Lock nut	2
9	HH-00789-003-14	3/16 14" Chain	1
10	90030-VSC	Power Cable, Cab Section (for EQVSC-10-D only)	1
10a	90030-VSC-6/8	Power Cable, Cab Section (for EQVSC-6/8-D only)	1
11	HH-00972-090	1/2-20 x 1.1/2 HHCS	4
12	HH-00540-004	1/2-20 Lock nut	4
13	HH-00455-007	#8x3/4 Screw	2
14	51335-22-M	Battery Cable 22"	1
14a	53608-01-N	Circuit breaker 80 Amp	1
14b	513335-56-M	Battery Cable 22"	1
15	HH-00013-073	#8-32 x 5/8" Screw	4
16	HH-00340-019	#8-32 Lock nut	4
17	90190-N	Solenoid continues Duty	1
18	90229-N	Light	1
19	53207-N	License Plate Plastic Nut	2
20	761232-M	Butt Connector	1
21	768222-048	Brown Wire 48" 14ga	1
22	769977-03	1/4" x 3" shrink tube	1
23	90308-A	4" Ground Wire	1
24	HH-00455-007	#8 Self tapping Screw	2
25	90309-A	Gray power wire c/w switch	1
26	EQTCVSC	Wireless control (single motor)	1

Wiring diagram for Electric Sander

2017 and After

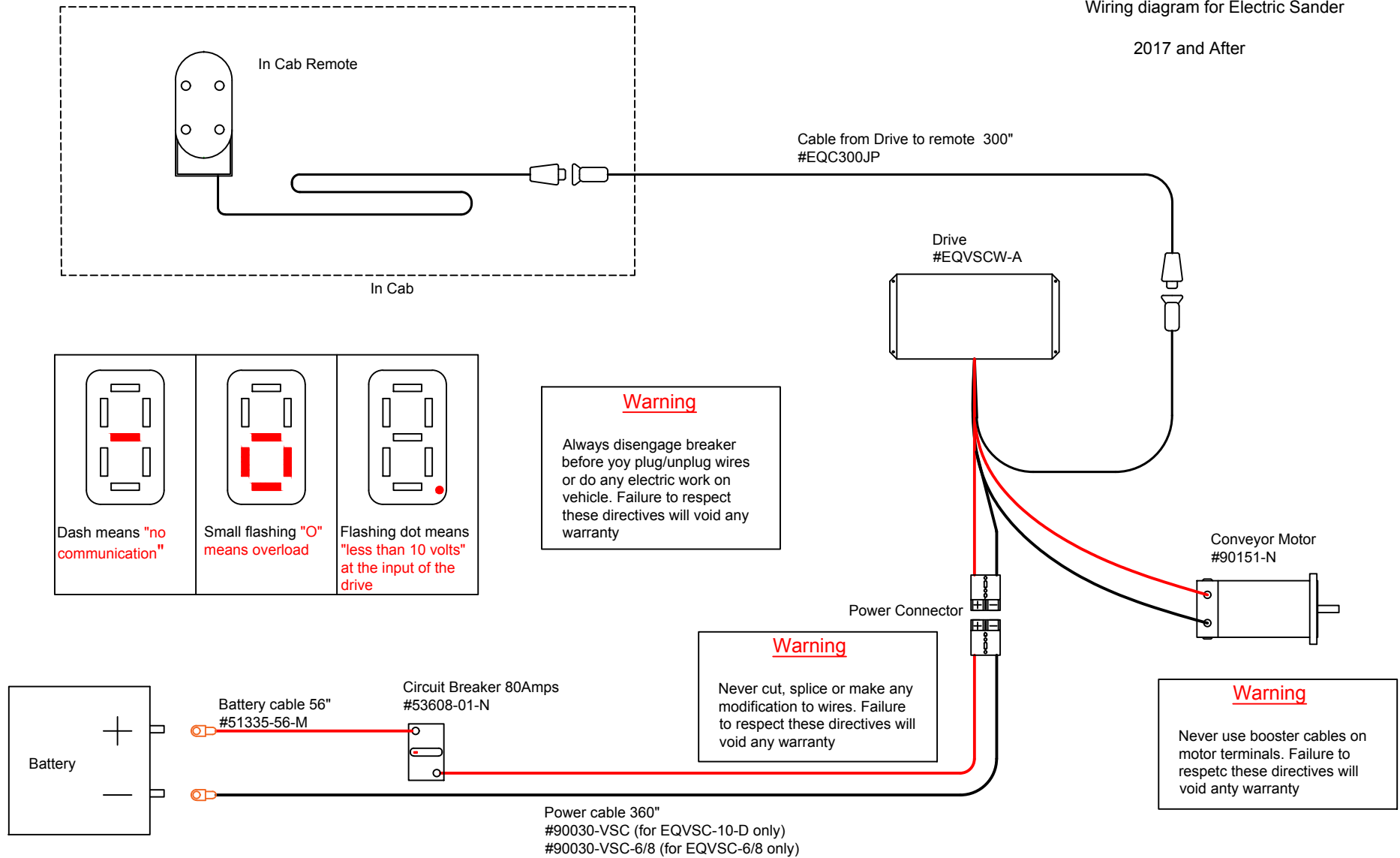

EQVSC-4/6/8 & EQVSC-10 Variable Speed Electric Control Kit (2017 & After)			
	Part #	Description	Quantity
1	EQVSCW-A	Variable Speed Control Kit (include box and controller)	1
2	HH-00020-081	1/8" x 3/4" Cotter Pin	1
3	90040-N	Sander Ratchet Strap	4
4	HH-00293-028	5/16-18 x 1 HHCS	3
5	HH-00341-003	5/16 Flatwasher	3
6	HH-00340-017	5/16-18 Lock nut	3
7	HH-01081-054	3/8-16 x 2.1/2 Grade	2
8	HH-00340-001	3/8-16 Lock nut	2
9	HH-00789-003-14	3/16 14" Chain	1
10	90030-VSC	Power Cable, Cab Section (for EQVSC-10-D only)	1
10a	90030-VSC-6/8	Power Cable, Cab Section (for EQVSC-6/8-D only)	1
11	HH-00972-090	1/2-20 x 1.1/2 HHCS	4
12	HH-00540-004	1/2-20 Lock nut	4
13	HH-00455-007	#8x3/4 Screw	2
14	51335-56-M	Battery Cable 56"	1
14a	53608-01-N	Circuit breaker 80 Amp	1
15	HH-00013-073	#8-32 x 5/8" Screw	4
16	HH-00340-019	#8-32 Lock nut	4
17	EQC3000JP	Wire for Remote Controller (25")	1
18	90229-N	Light	1
19	53207-N	License Plate Plastic Nut	2
20	90313-N	Repair Harness Kit (Female Box End)	1
21	90314-N	Repair Harness Kit (Male Remote End)	1
24	HH-00455-007	#8 Self tapping Screw	2

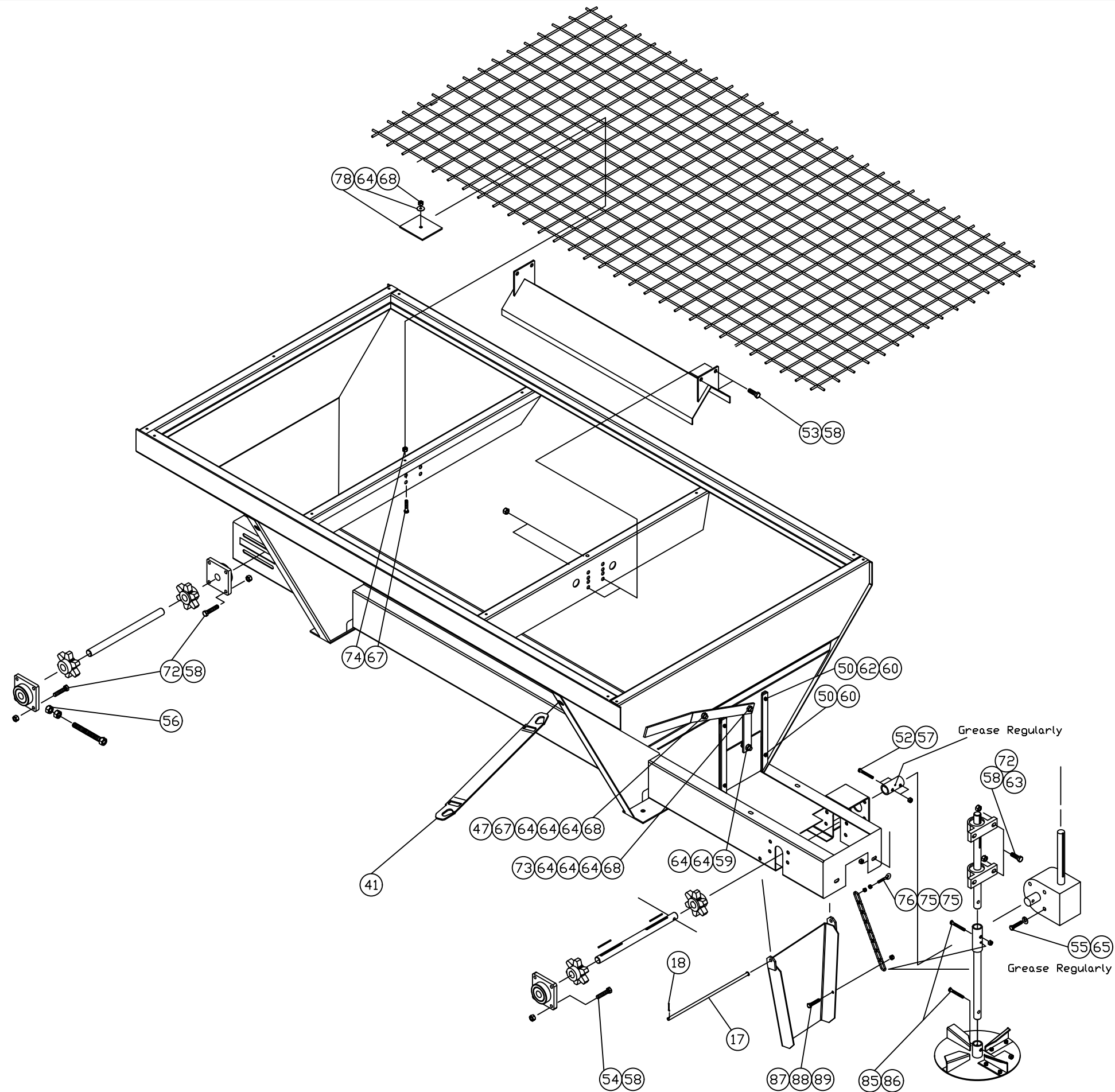

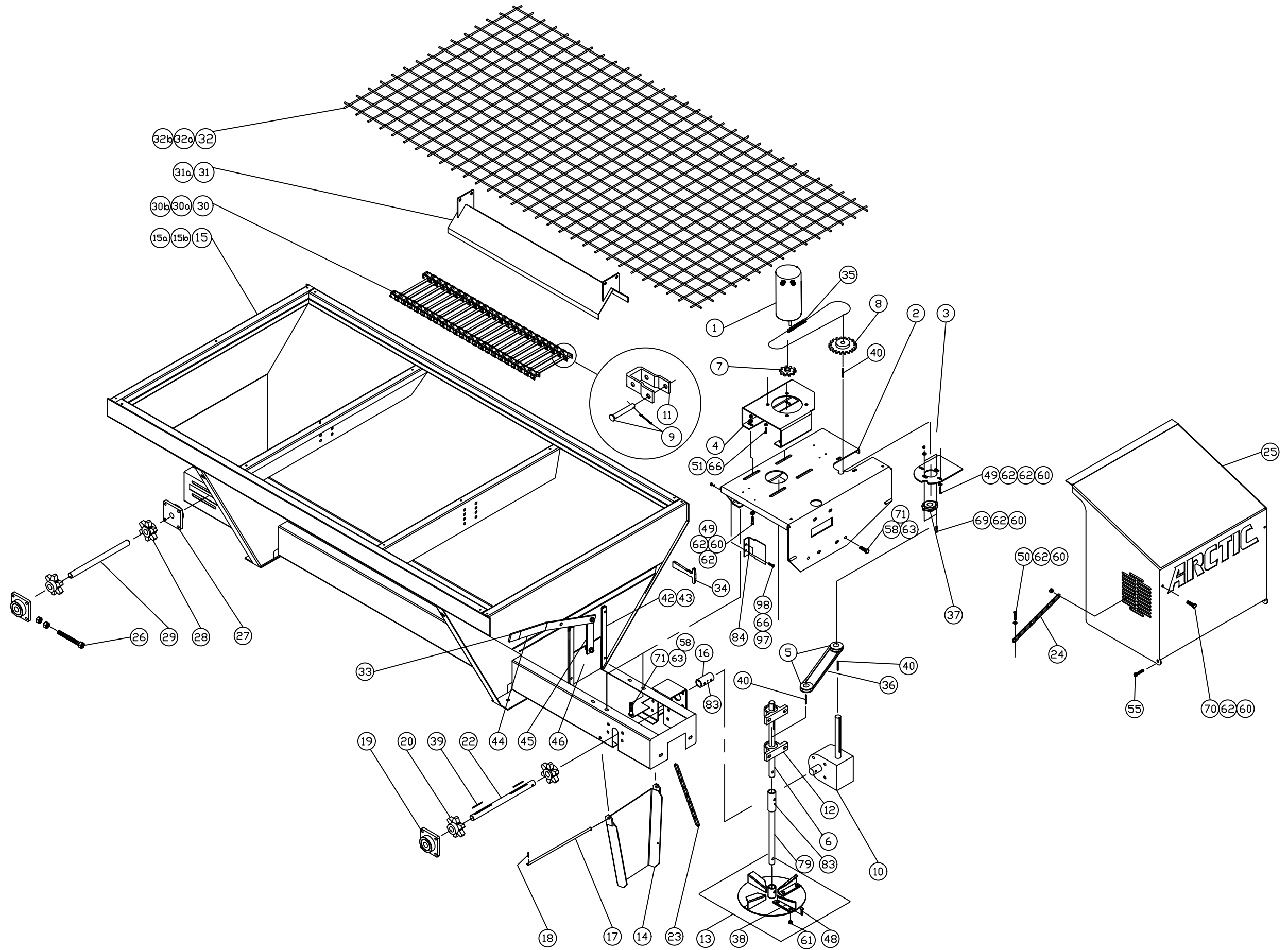

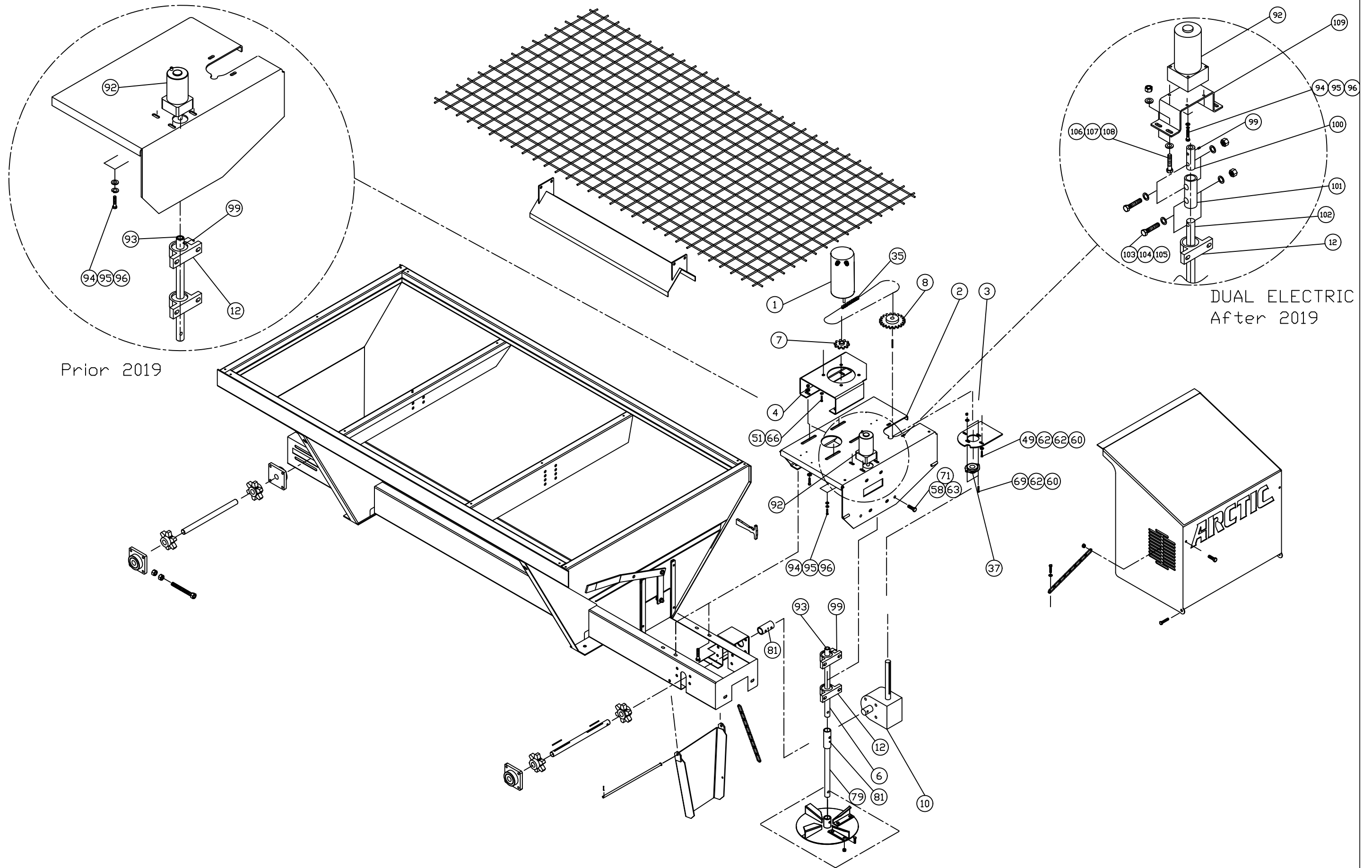

Prior 2019

DUAL ELECTRIC
After 2019

Galvanized Sander AG4, AG6, AG8, AG10 With Electric Motor			
	Part #	Description	Qty
1	90151-N	Electric Motor ¾" HP	1
2	90117-C	Mounting Plate	1
3	90118-A	Top Bearing Plate	1
4	90161-B	Platform for Electric Motor	1
5	90090-N	Gearbox Pulley, 2.3"	2
6	90162-B	Top Spinner Shaft	1
7	90152-N	Sprocket motor side, 2"	1
8	90153-N	Sprocket gear box side, 6"	1
9	RB-32992-05	Chain Connecting Pin	1
10	90150-N	Gear Box 50:1	1
11	RB-32992-04	Chain Connecting Link	1
12	HH-00905-013	Spinner Bearing	2
13	RB-889	Spinner Disc	1
14	RB-32996	Chute	1
15	90371-D	Sander, 4' body weldment	1
15a	90093-D	Sander, 6', body weldment	1
15b	90094-D	Sander, 8', body weldment	1
15c	90095-D	Sander, 10', body weldment	1
16	90119-B	Drive Coupling	1
17	RC-32854-02	Hinge Pin for sander chute	1
18	HH-00020-081	Cotter Pin, 1/8" dia x 3/4" lg	1
19	HH-00859-019	Drive Shaft Bearing, Four Bolt Flange	1
20	RB-872	Drive Sprocket	2
22	90120-B	Drive Shaft	1
23	HH-00789-003-14	Chain , 3/16" dia x 14" long	1
24	HH-00789-003-20	Chain , 3/16" dia x 20" long	2
25	90128-D	Hood	1
26	90131-A	Bolt for idler bearing (chain tightener)	2
27	HH-00859-014	Idler Shaft Bearing, Four Bolt Flange	2
28	RB-874	Idler Sprocket	2
29	RB-876	Idler Shaft	1
30	RB-32992-06E	Chain, AG4 only	1
30a	RB-32992	Chain, AG6 only	1
30b	RB-32992-02-E	Chain, AG8 only	1
30c	RB-32992-03-E	Chain, AG10 only	1
31	90114-96-C	V Channel, AG8	1
31a	90114-120-C	V Channel, AG10	1
32	90318-N	Screen, AG4	1
32a	90133-N	Screen AG6	1
32b	90134-N	Screen AG 8	1
32c	90135-N	Screen AG10	1
33	90252-N	Rubber Grip for Gate Handle	2

Galvanized Sander AG4, AG6, AG8, AG10 With Electric Motor			
	Part #	Description	Qty
34	HH-00857-006	Hood Latch	2
34a	HH-00013-074	#8 x 3/4" Screw	12
34b	HH-00340-019	#8 Lock nut	12
35	90182-M	Electric Motor drive chain (35")	1
36	90148-N	Belt, Gearbox to Spinner Shaft, A31	1
37	HH-00960-009	Bearing (to support gear box input shaft)	1
38	90168-A	Replaceable Spinner Disc Fin – part of RB-889	1
39	HH-00291-101	Key 1/4" Square x 2.75"	1
40	HH-00291-102	Key 1/4" Square x 1.50"	3
41	90040-N	Strap	4
42	90124-B	Gate Guide, top plate	2
43	90123-B	Gate Guide, bottom plate	2
44	90126-B	Gate Arm	1
45	90125-A	Gate Middle Link	1
46	90122-A	Gate	1
47	HH-00972-092	1/2"-20 UNF x 2" HHCS	1
48	HH-00293-003	1/4" -20 UNC x 5/8" HHCS	8
49	HH-00293-028	5/16"-18 UNC x 1" HHCS	5
50	HH-00293-029	5/16" -18 UNC x 1 1/4" HHCS	6
51	HH-00293-049	3/8"-16 UNC x 1" HHCS	4
52	HH-00293-055	3/8" -16 UNC x 2 1/2" HHCS	2
53	HH-00293-069	7/16"-14 UNC x 1" HHCS	4
54	HH-00293-072	7/16" -14 UNC x 1 3/4" HHCS	4
55	HH-00293-088	1/2"- 13 UNC x 1" HHCS	6
56	HH-00294-007	5/8" -11 UNC Nut	4
57	HH-00340-001	3/8"-16 UNC Lock Nut	2
58	HH-00340-002	7/16"-14 UNC Lock Nut	24
59	HH-00340-003	1/2"-13 UNC Lock Nut	1
60	HH-00340-017	5/16" – 18 UNC Lock Nut	15
61	HH-00340-901	1/4" – 20 UNC Lock Nut	8
62	HH-00341-003	5/16" Flat Washer	18
63	HH-00341-005	7/16" Flat Washer	8
64	HH-00341-006	1/2" Flat Washer	9
65	HH-00457-001	1/2" Lock Washer	4
66	HH-00457-004	3/8" Lock Washer	8
67	HH-00460-002	1/2" – 20 UNF Nut	2
68	HH-00540-004	1/2" – 20 UNF Lock Nut	3
69	HH-00971-043	5/16" -18 UNC x 1" Carriage Bolt	2
70	HH-00971-044	5/16" -18 UNC x 1.25" Carriage Bolt	2

Galvanized Sander AG4, AG6, AG8, AG10 With Electric Motor			
	Part #	Description	Qty
71	HH-00971-104	7/16" -14 UNC x 1" Carriage Bolt	4
72	HH-00971-106	7/16" -14 UNC x 1.5" Carriage Bolt	12
73	HH-00972-090	½" -20 UNF x 1.5" HHCS	1
74	HH-00972-091	½" -20 UNF x 1.75" HHCS	1
75	HH-00294-002	5/16"-18 Hex Nut	2
76	HH-01149-008	5/16"-18 x 3.75" Eyebolt	1
77	RB-38759	Mounting Stop Angle (Not Shown)	1
78	90154-A	Plate, Poly, Screen Hold Down	1
79	90165-B	Bottom Split Spinner Shaft	1
79a	90167-B	Bottom Split Spinner Shaft Extended	1
81	HH-00233-001	¼"-28 Grease fitting	5
82	HH-01081-054	3/8 16x 2 ½ Grade 8 bolt	2
84	90115-03-B	Plate, Sand Guide	2
85	HH-01081-054	3/8-16 x 2.5 grade 8	2
86	HH-00340-001	3/8 -16 Nut with Nylon Insert	2
87	HH-00293-028	5/16" -18 UNC x 1"	1
88	HH-00341-003	5/16" Flat washer	1
89	HH-00340-017	5/16" -18 UNC Hex locknut	1
90	HH-00972-090	½"-20 UNF x 1.5" HHCS	4
91	HH-00540-004	½"-20 UNF Lock Nut	4
92	90307-N	Gear Motor (dual motor)	1
93	90306-B	Spinner Shaft (dual motor only) (prior 2019)	1
94	HH-00909-003	M6x20mm hex bolt (dual motor)	4
95	HH-00932-001	M6 Flat Washer (dual motor)	4
96	HH-00933-001	M6 Lock Washer (dual motor only)	4
97	HH-00294-003	3/8" Nut	4
98	HH--00293-049	3/8" x 1" Bolt	4
99	HH-00017-024	1/4-20x1/4 set screw (dual motor only)	2
100	90322-A	Small Coupler, 2.5" (dual motor only 2019+)	1
101	90323-A	Hose Coupling- Dual Electric (dual motor only 2019 +)	1
102	90321-B	Long shaft, 15.5" (dual motor only 2019+)	1
103	HH-00293-010	¼"x2" HHCS (dual motor only 2019+)	2
104	HH-00341-002	¼ Flat washer (dual motor only 2019+)	4
105	HH-00340-901	¼ locknut, coarse (dual motor only 2019+)	2
106	HH-00293-028	5/16" -18 UNC x 1" (dual motor only 2019+)	4
107	HH-00341-003	5/16" Flat washer (dual motor only 2019+)	8
108	HH-00340-017	5/16" -18 UNC Hex locknut (dual motor only 2019+)	4
109	90320-B	Spinner Motor Mounting Plate	1

Arctic Equipment Manufacturing Corporation reserves the right under its product improvement policy to change construction or design details and furnish equipment when so altered without reference to illustrations or specifications used.