

Galvanized Hydraulic Spreader

Models AG6H/AG8H/AG10H

Warning:

Do not exceed GVWR or GAWR with spreader and load. Overloading could result in an accident or damage.

Read this manual and engine owner's manual before installing or operating the spreader.

Sander Warranty

ARCTIC salt/sanding equipment is guaranteed to be free from defects in material or workmanship under normal use and service for 1 (one) year after the date of purchase.

Arctic Equipment Manufacturing Corporation will replace or repair, at its election, without charge, any part which becomes defective within the period of time described above. Hydraulic motors, pumps and gear reducer, etc. are also covered under warranty for a period of one year, with normal use.

See specifications below what is not covered under warranty.

In no event shall Arctic Equipment Manufacturing Corporation be liable for claims for loss of use or consequential damages.

This warranty is made only to the original purchaser. There is no other warranty expressed, implied, or statutory.

All parts returned to us, transportation charges prepaid, must be accompanied with a "Return Goods Authorization" number, obtained from the factory. In order to reduce down-time, we will, on your request, send the parts required and you will be billed under the usual terms. A credit will be issued to your account when the parts, in our examination, prove to be defective. Arctic Equipment Manufacturing Corporation reserves the right to change specification without prior notice.

Warranty does not cover:

- Paint or surface coating deterioration, parts such as, drive chain, conveyor chain, belts, controller keypad, bushings, stripped keyways or splines on external shafts, nuts and bolts or tightening nuts and bolts which are considered normal maintenance.
- Problems caused by failure to follow instructions and failure to maintain the product as described in the owner's manual.
- Damage resulting from rust, corrosion, freezing or overheating; failure to maintain proper fluid/lubrication levels, using other than recommended grade and type of lubrication, failure to retighten fasteners, chains and belts.
- Damage to the product that has been subject to misuse, neglect, accident, or improper installation (mounting), maintenance, care or storage.
- Repairs by an unauthorized person (dealer).
- Damage caused by parts not used in accordance with their intended purpose.
- Damage due to abrasion of wiring harnesses.
- Travel time incurred to and from dealers or suppliers, accommodations, meals, cost of tax, freight to/from dealers, storage charges, environmental charges, solvents, sealants, lubricants.
- Problems caused by accessories and parts that are not supplied by Arctic Equipment.
- Liability for damage to the property, or injury to, or death of any person arising out of the operation, maintenance or use of the covered product.

The customer can register their equipment through Arctic website <http://www.arcticsnowplows.com/warranty> .

Arctic Equipment Manufacturing Corporation reserves the right to change specification without prior notice.

Customer Responsibility

The loaded vehicle, including all after market accessories, the salt/sanding equipment, passengers, and cargo, **MUST NOT** exceed the gross vehicle weight ratings (GVWR), front gross axle weight rating (FGAWR) or rear gross axle weight rating (RGAWR) specified on the Safety Compliance Certification Label located in the driver's side door opening. **It is the operator's responsibility to verify that these ratings are not exceeded.**

To determine the Gross Axle Weights for your vehicle, including all after market accessories, the salt/sanding equipment, passengers, and cargo, take your loaded vehicle to a scale. Place the front wheels of the vehicle on the scale to get the Front Gross Axle Weights (FGAW). To get the Rear Gross Axle Weights (RGAW), place the back wheels of the vehicle on the scale.

Disclaimer notice

Arctic Equipment Manufacturing Corporation (Arctic) does not assume liability for damage to your motor vehicle resulting from the attachment or use of Arctic salt/sanding equipment. The purchaser assumes all vehicle risk associated with the attachment and operation of this salt/sanding equipment.

The added weight may impair the operation and control of your vehicle. Additional equipment may be necessary before installing salt/sanding equipment. Please consult your vehicle dealers prior to the purchase and installation of the salt/sanding equipment.

Ordering parts

Delays and errors can be eliminated if ordering instructions are followed correctly.

1. Place orders direct with Arctic Equipment Manufacturing or nearest dealer.
2. State company name, address, and postal/zip code.
3. Give exact model and serial number of the machine (stamped on the unit identification plate).
4. Furnish part number, description and quantities required.
5. Print or type order clearly.
6. Give specific shipping instructions.

Galvanized Hydraulic Spreader

WARNING:

- Do not exceed the gross vehicle weight ratings (GVWR), front gross axle weight rating (FGAWR) or rear gross axle weight rating (RGAWR) with spreader and load. Overloading could result in an accident or damage.(Refer to Material Density chart below)

Material Density

(lb per cubic yd)

Fine Salt – Dry 1400

Coarse Salt – Dry 1300

Coarse Sand – Dry 2800

Coarse Sand – Wet 3300

Before attempting any procedure in this book, read and understand all the safety information contained in this section. In addition, ensure all individuals working with you are also familiar with these safety precautions.

For your safety, warning and information decals have been placed on this product to remind the operator to take safety precautions. It is important that these decals are in place and are legible before operation begins. New decals can be obtained from Arctic Equipment Manufacturing or your local dealer.

Remember it is the owner's responsibility for communicating information on the safe use and proper maintenance of this equipment. The careful operator is the best operator. Most accidents are caused by human error. Certain precautions must be observed to prevent the possibility of injury to operator or bystanders and/or damage to equipment.

- Empty and clean the hopper and wash off all external surfaces after each use.
- Driver to keep bystanders minimum of 25 feet away from operating spreader.
- Servicing the sander without special tools and knowledge could result in personal injury. See an authorized Arctic dealer for service.
- Before servicing the spreader, wait for conveyor or spinner to stop, then lock out power.
- Do not climb into or ride on spreader.
- Disconnect electric and/or hydraulic power and tag out if required before servicing or performing maintenance.
- Do not allow hands, hair or clothing to get near any moving parts such as spinner, chain etc.
- Do not wear neckties or loose clothing when working on the vehicle. These things can catch on moving parts or cause an electrical short circuit that could result in personal injury. Do not wear wrist watches, rings or other jewellery when working on the vehicle or individual equipment
- Do not allow unauthorized person to operate this unit.
- Do not work on a vehicle without having a fully serviced fire extinguisher available. (Dry chemical unit specified for gasoline, chemical or electrical fires).
- Do not smoke while working on the vehicle. Gasoline and battery acid vapours are extremely flammable and explosive.

- Do not alter the sander, or any part without written approval of Arctic Equipment Manufacturing Corporation.
- Do not use your hands to search for hydraulic fluid leaks; escaping fluid under pressure can be invisible and can penetrate the skin and cause injury.
- Do not leave unused material in hopper. Material can freeze or solidify, causing unit to not work properly. Empty and clean after each use.
- Inspect the sander periodically for defects. Parts that are loose, broken, missing or plainly worn must be tightened or replaced immediately.
- Check the job site for terrain hazards, obstructions and people. Check surrounding area for hazardous obstacles before operating this unit.
- Wear safety goggles when working on the vehicle to protect your eyes from battery acid, gasoline, and dust or dirt from flying off of moving engine parts.
- Be aware of and avoid contact with hot surfaces such as engine, radiator, and hoses.
- Wear safety glasses with side shields when striking metal against metal. Failure to heed could result in injury to the eye(s) or other parts of the body.
- Shut off the vehicle engine, place the transmission in neutral or park, turn the ignition switch to the "off" position, firmly apply the parking brake of the vehicle before attaching or detaching the blade from the vehicle or when making adjustments to the blade.
- Be sure that the sander is properly attached before moving the vehicle.
- To remove the sander, the unit must be empty. Do not stand close to the sander when it is being lifted. Keep a safe distance away.

Operation

These models are to be powered by an under hood hydraulic pump which is driven by the trucks engine, by a double V-belt. A cab mounted switch activates an electric clutch which in turn drives the pump. This feature not only allows the conveyor to be turned on and off but also prevents unnecessary pump wear.

The oil from the pump feeds the oil tank mounted flow control valve. The valve diverts a preset amount of oil to the spinner/drive motor. It can be set, by means of a control lever, to direct from 0-8 GPM to the motor. By varying the flow, both the discharge rate and spread pattern width can be adjusted. The gate opening on this model also affects the discharge rate of the unit. One point that should be kept in mind is that as conveyor slows down (low oil flow) so does the spinner. Therefore, the spread width becomes narrower.

In order for the system to work properly throughout the entire design range, the pump must deliver a minimum of 5 GPM. If the pump is driven by a 1:1 ratio V-belt setup, the flow should be achieved at 1500 RPM. The valve is designed to only allow a maximum of 8 GPM to pass the motor. Any excess flow from the pump is bypassed to the tank.

This model is equipped with an adjustable sand discharge chute. You can vary the spread width by simply redirecting the sand to another part of the spinner.

Note: Factory ordered pumps are equipped with an electric clutch. Dealer supplied units may not be so equipped.

Spreader Installation

The AG6H spreader is designed for installation in a 6'/8' pickup truck bed. The AG8H is designed for installation in an 8' pickup truck bed. The AG10H spreader is designed for 10' dump truck or flat deck truck. Follow the steps below to install your unit in your vehicles.

a) Slide spreader into position and secure with the ratchet straps into the cargo tie downs of the truck (pictures # 3 and #4)

Note: The oil tank should be mounted in the front left corner of the bed, before installing the spreader. The unit is designed to mount against the side of the bed flange and to the floor. The oil level eye should face outwards from the bed.

b) Bolt mounting angle bracket to spreader, then bolt it to the back of the truck using ½" bolt. (picture #2)

c) Install the sand chute using the required pivoting/fastening components. (picture #12)

d) Assemble the spinner assembly (split shafts), as shown in the assembly drawing in this manual, using the appropriate components. (picture #5, 10, 11 and 12)

e) You may change the spinner disc height. Using the hole in the spinner disc hub as a guide, drill a hole through the shaft, for the mounting bolt. Cut off any excess length from the shaft and install the spinner disc.

f) Connect all the lines (not supplied) as shown in the hydraulic system diagram (reference). Be sure all the fittings are tight and do not leak.

g) If your unit is equipped with a hydraulic pump, mount the unit in an appropriate location under the hood. Install and connect the pump clutch switch, as shown in the literature supplied with the pump.

h) You may use quick disconnect couplers (not supplied) to remove the sander when not required. Connect the two hoses together or use protective plugs and caps, on the couplers, when the unit is removed. This will protect the couplers and prevent system contamination.

Maintenance

Daily Inspection and Lubrication

a) Check gearbox oil level. It should be filled to the oil level plug. (Picture#1)

b) Check hydraulic oil tank level. Level should be at the centre of the sight eye.

c) Lubricate the following grease nipples:

- 1) 1 on conveyor idler shaft bearing (2 bearings) (picture #8)
 - 2) 1 on drive shaft bearing (picture #7)
 - 3) 1 on spinner shaft bearing (2 bearings if one hydraulic motor is used, 1 bearing if two hydraulic motors are used) (Picture #11)
 - 4) 1 on “U”-Joint (if two hydraulic motors are used)) (picture #10)
 - 5) 1 on each coupling split shaft and gear box coupling (pictures #5 and #6)
- d) Check the hydraulic hoses and fittings for leaks, as well as the pump drive belts for wear, at least once a week.

Yearly Inspection

- a) At the end of the operating season, the unit should be thoroughly cleaned and lubricated. The conveyor chain (picture #9) should, ideally, be stored in oil. These preventative measures should prevent premature rusting of the unit. Grease bolts on the chain tighteners (picture #8)
- b) At this time or before the start of the next season, it is wise to check all drive components for appreciable wear. Any components which are questionable should be replaced now. This short and simple check will avoid down time during the operating season.
- c) Change the gear box oil.
- e) Replace the oil filter. (Note: If the unit is utilized year round, replace it twice a year).

Before Operating

- a) Grease all lubrication points.
- b) Ensure that the conveyor chain is dragging for one foot on the bottom return channel, of the spreader. (Do not over tighten the chain).
- c) Ensure all hydraulic fittings are tight.
- d) The hydraulic oil level, in the tank, should be at the center of the oil level eye.

Lubricants

Hydraulic Oil.....Texaco Rando HD22 or approved equivalent
Speed Reducer Lubricant.....80W90 Gear lube



Picture #1



Picture #2



Picture #3



Picture #4



Picture #5



Picture #6



Picture #7



Picture #8



Picture #9



Picture #10



Picture #11

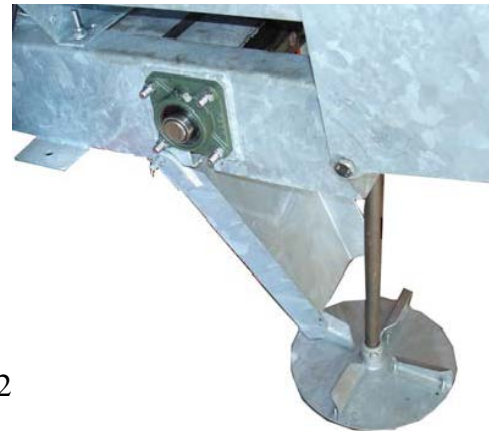

Picture#12

HYDRAULIC SYSTEM INSTALLATION (Diagram for reference only)

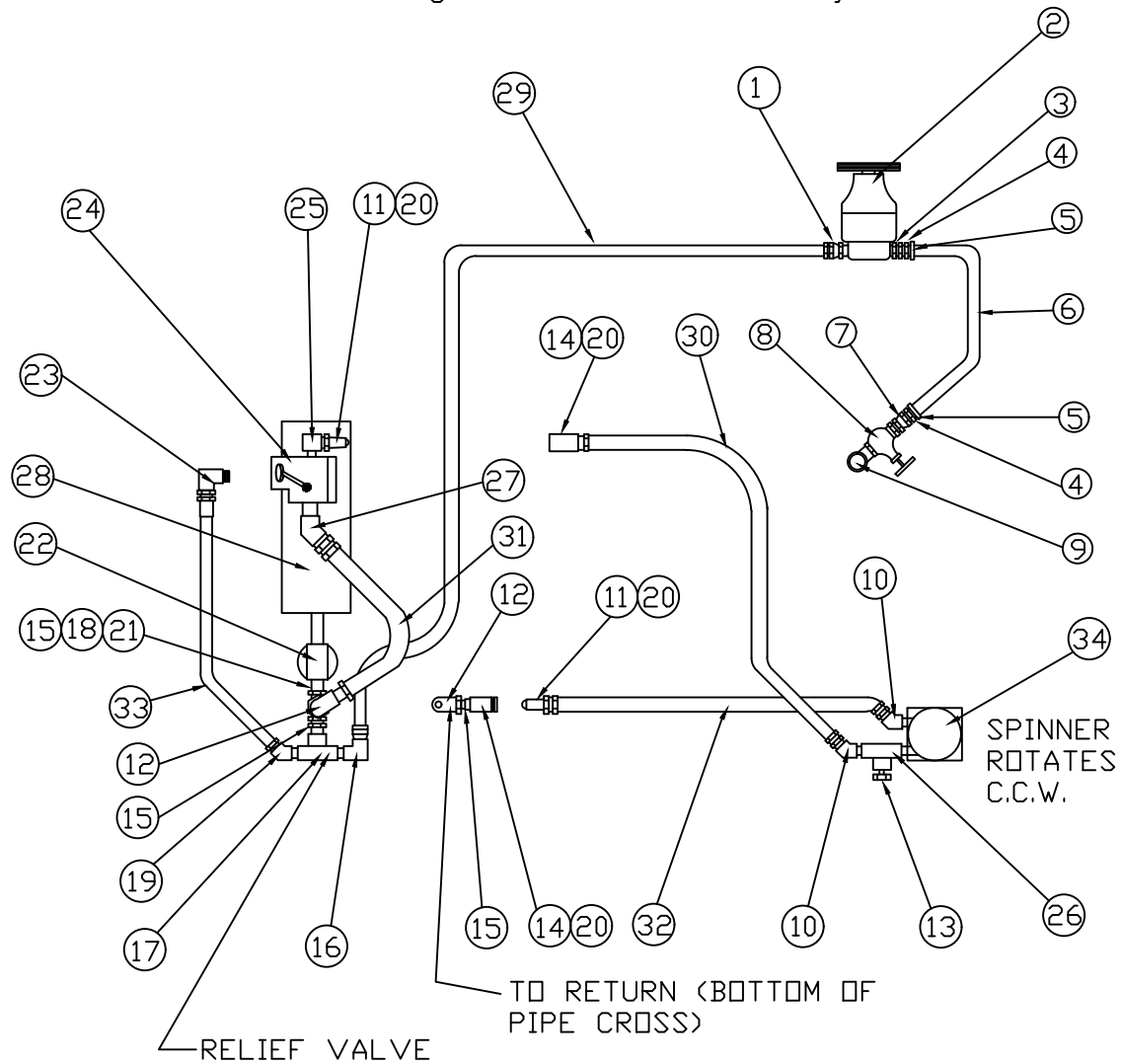

Hydraulic System Installation RC-32890 rev 1				
Item	Part #	Description	RC-32890	RC-32890-01
1	HH-00794-010	Str. Swivel, ¾" M x ½" FM NPT	Optional	Optional
2	RM-32889-01	Belt Drive Pump	Optional	Optional
3	HH-00794-019	Str. Swivel ¾" M x 1" FM NPT	Optional	Optional
4	HH-00850-002	Hose end fitting 1" (not supplied)	2	-
5	HH-00627-002	Hose clamp	2	-
6	HH-00849-002	Suction hose 1" x A/R Lg. (not supplied)	1	-
7	HH-00794-013	Str. Swivel 1" M x 1" F/M NPT	1	1
8	HH-00844-005	Gate valve 1" NPT	1	1
9	HH-00048-006	90° Elbow street 1" M x 1" FM NPT	1	-
10	HH-00915-005	45 deg Elbow Swivel ½" M x ½" FM NPT	4	4
11	HH-00888-035	Quick Disconnect FM ½" NPT (not supplied)	2	-
12	HH-00048-004	90 deg Elbow str. ½" M x ½" FM NPT	1	-
13	HH-00853-004	Hex plug ½" NPT	1	2
14	HH-00888-028	Quick Disconnect – female ½" NPT (not supplied)	2	-
15	HH-00051-004	Close Nipple ½" NPT	2	2
16	HH-00790-007	90 deg Elbow swivel ¾" M x ½" Fm NPT	1	1
17	RM-32986	Relief valve	1	1
18	HH-00088-007	Reducer ¾" M x ½" FM NPT	2	2
19	HH-00915-012	45 Deg Elbow swivel ¾" M x ½" FM NPT	1	1
20	HH-00928-003	Quick disconnect cap and plug (not supplied)	2	-
21	HH-00948-004	Pipe cross ½" FM NPT	1	-
22	RM-32828	Filter assembly	1	1
23	HH-00790-006	90 deg Elbow swivel ½" M x ½" FM NPT	1	1
24	RM-32829	Flow control valve	1	-
25	HH-00882-006	90 deg Elbow ½" M x ½" M NPT	1	1
26	HH-00843-004	Tee service ½" NPT (not supplied)	1	-
27	HH-00915-005	45 deg Elbow Swivel ½" M x ½" FM NPT (not supplied)	1	-
28	RE-32874-00	Oil Tank 8 gal	1	1
29	HH-00846-204	Hose ass'y, ½" x A/R Lg. (not supplied)	1	-
30	HH-00846-120	Hose ass'y ½" x 120" Lg. (not supplied)	1	-
31	HH-00846-024	Hose ass'y ½" x 24" Lg. (not supplied)	1	-

Hydraulic System Installation RC-32890 rev 1				
Item	Part #	Description	RC-	RC-32890-
		supplied)		
32	HH-00846-108	Hose ass'y 1/2" x 108" Lg. (not supplied)	1	-
33	HH-00846-024	Hose ass'y 1/2" x 24" Lg. (not supplied)	1	-
34	RM-32723	Hydraulic motor (comes with hydraulic kit)	-	-
35	HH-00852-000	Filler / breather cap (not shown)	1	1
36	HH-00394-001	3/4 Oil gauge (not shown)	1	1
37	HH-00038-005	3/4 Pipe plug (not shown)	1	1
38	RB-38770-18	Bushing I.D 01" O.D 01.1/2 x 3" long(not shown)	1	1
39	HH-00457-004	(WL53) 3/8 lock washer (not shown)	4	-

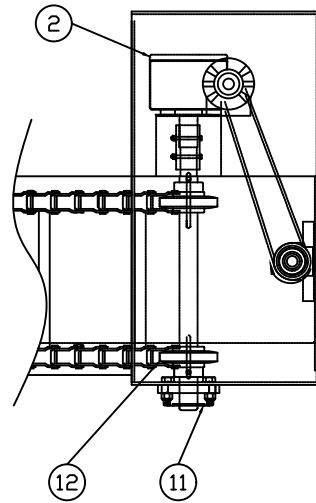

Drive detail of hydraulic sander (using one hydraulic motor)

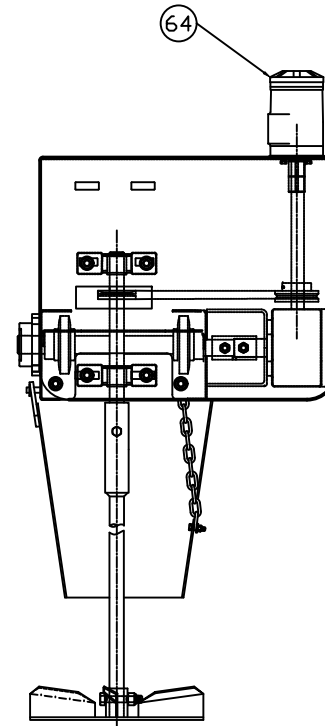
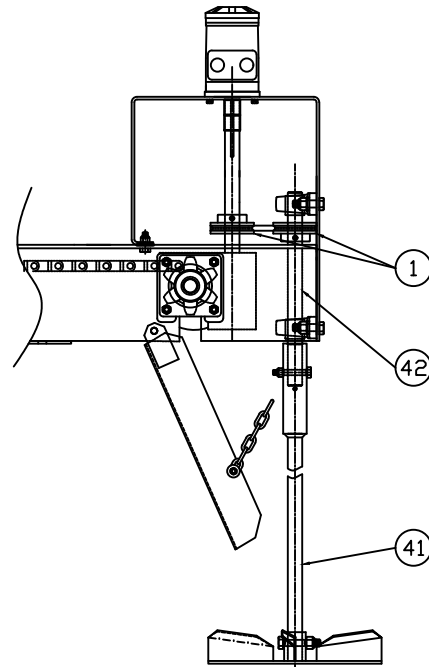

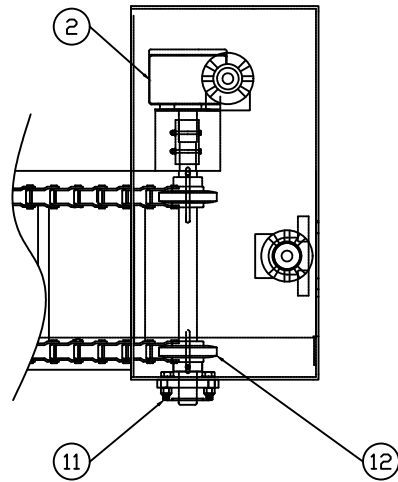

Drive detail of
hydraulic sander
(using two
hydraulic motors)

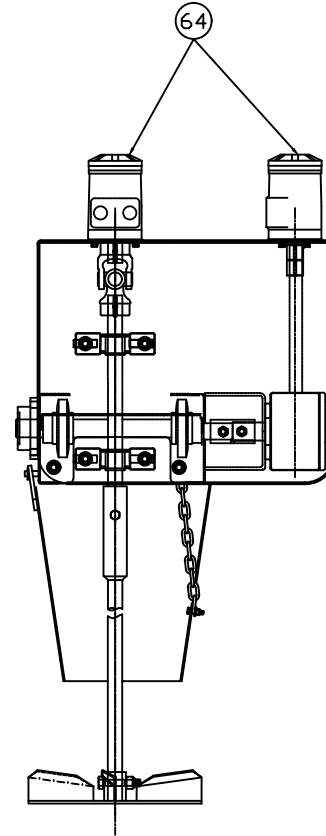
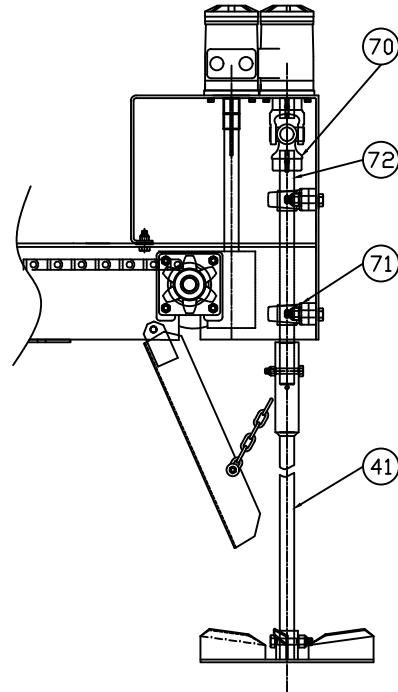

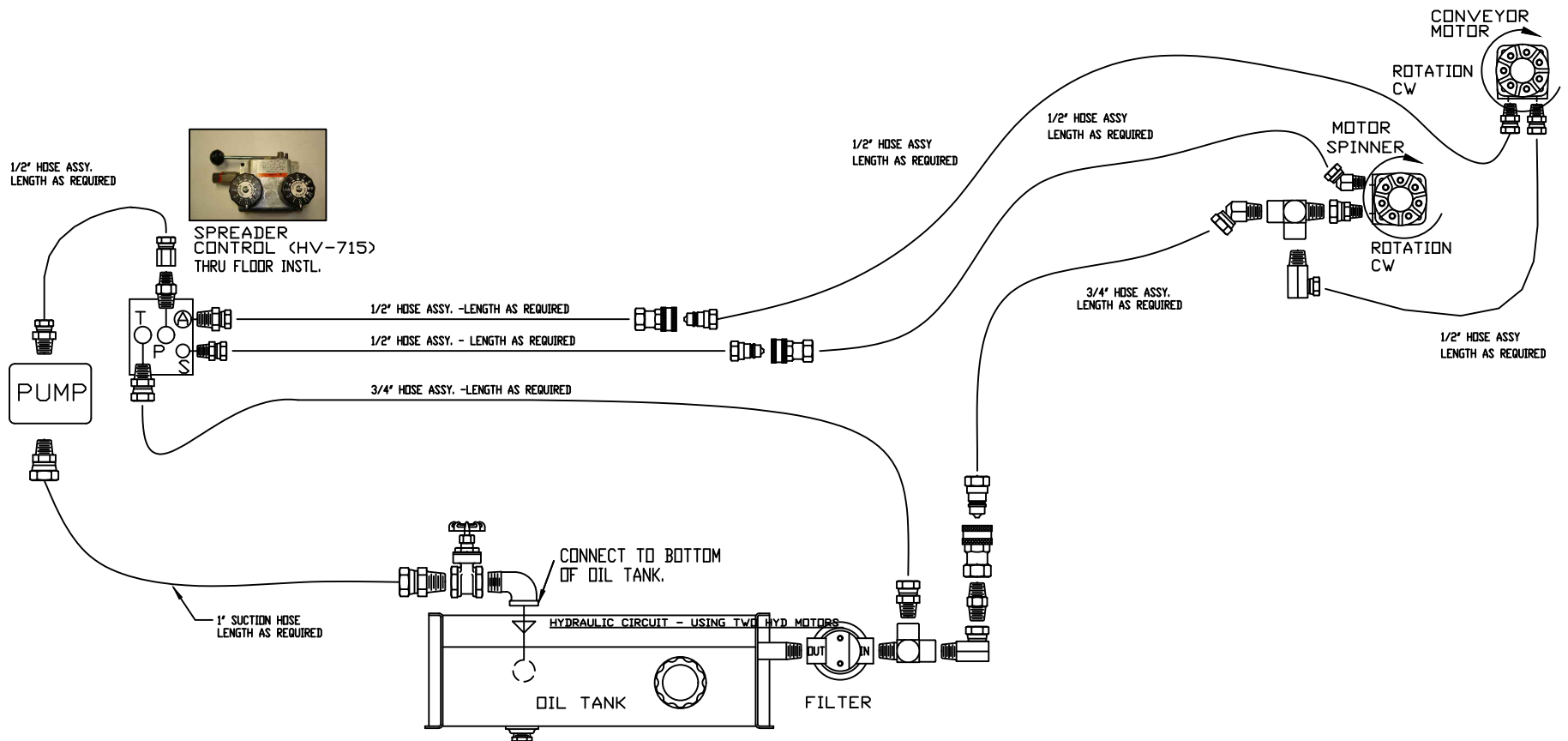

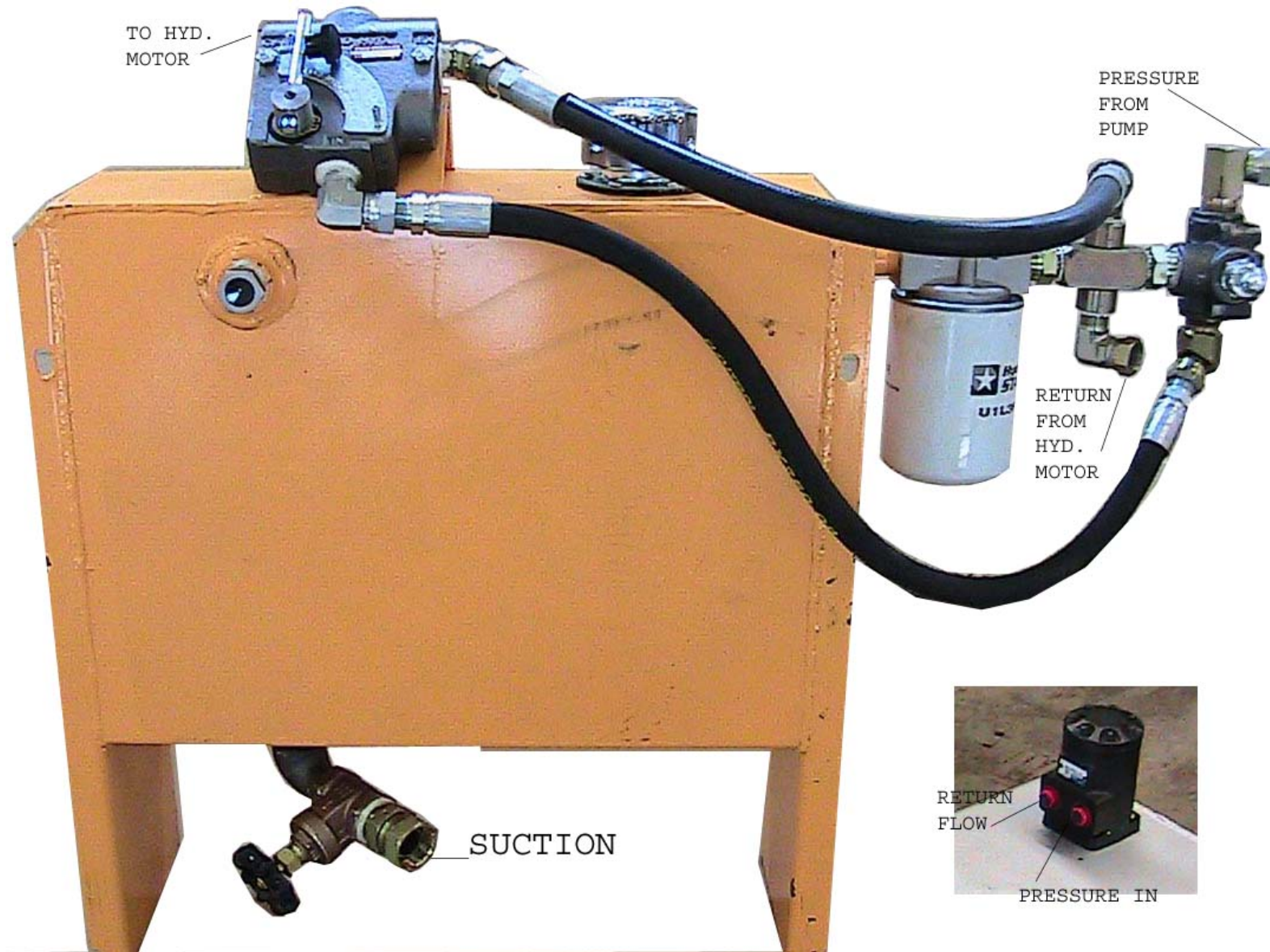

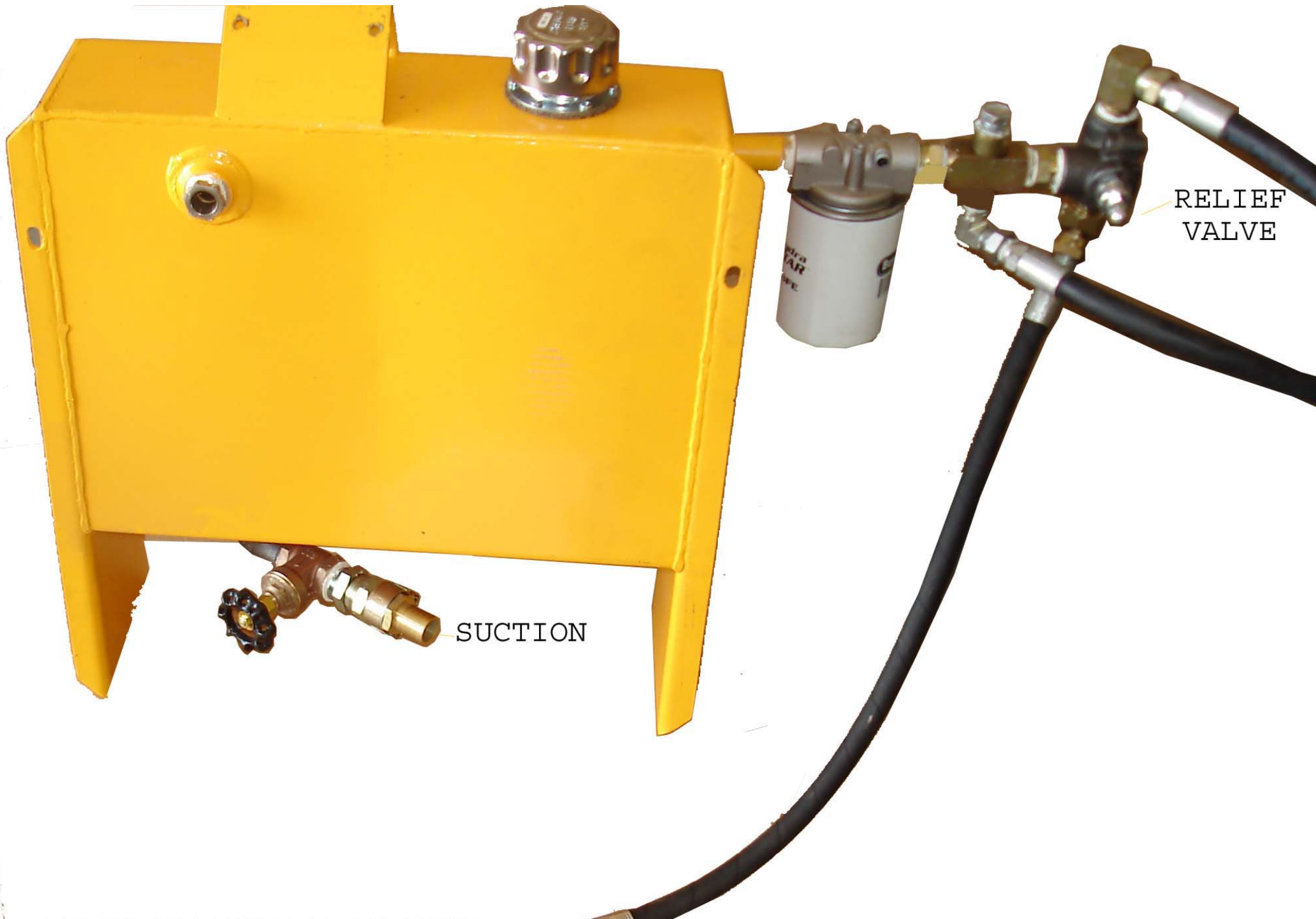

SUCTION

RELIEF
VALVE

Hydraulic Galvanized Sander
AG6H, AG8H & AG10H

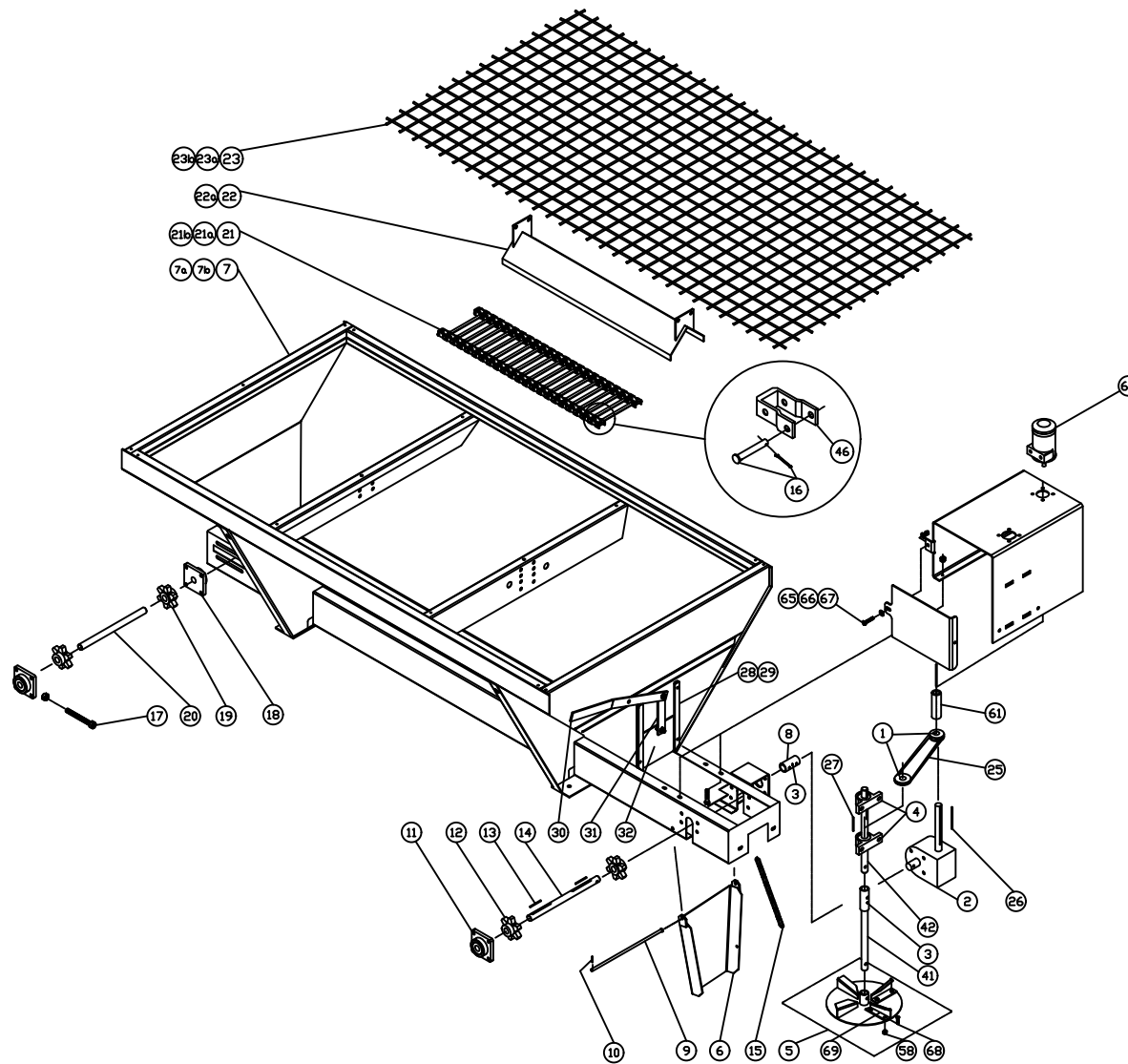

Hydraulic Galvanized Sander AG6H, AG8H & AG10H

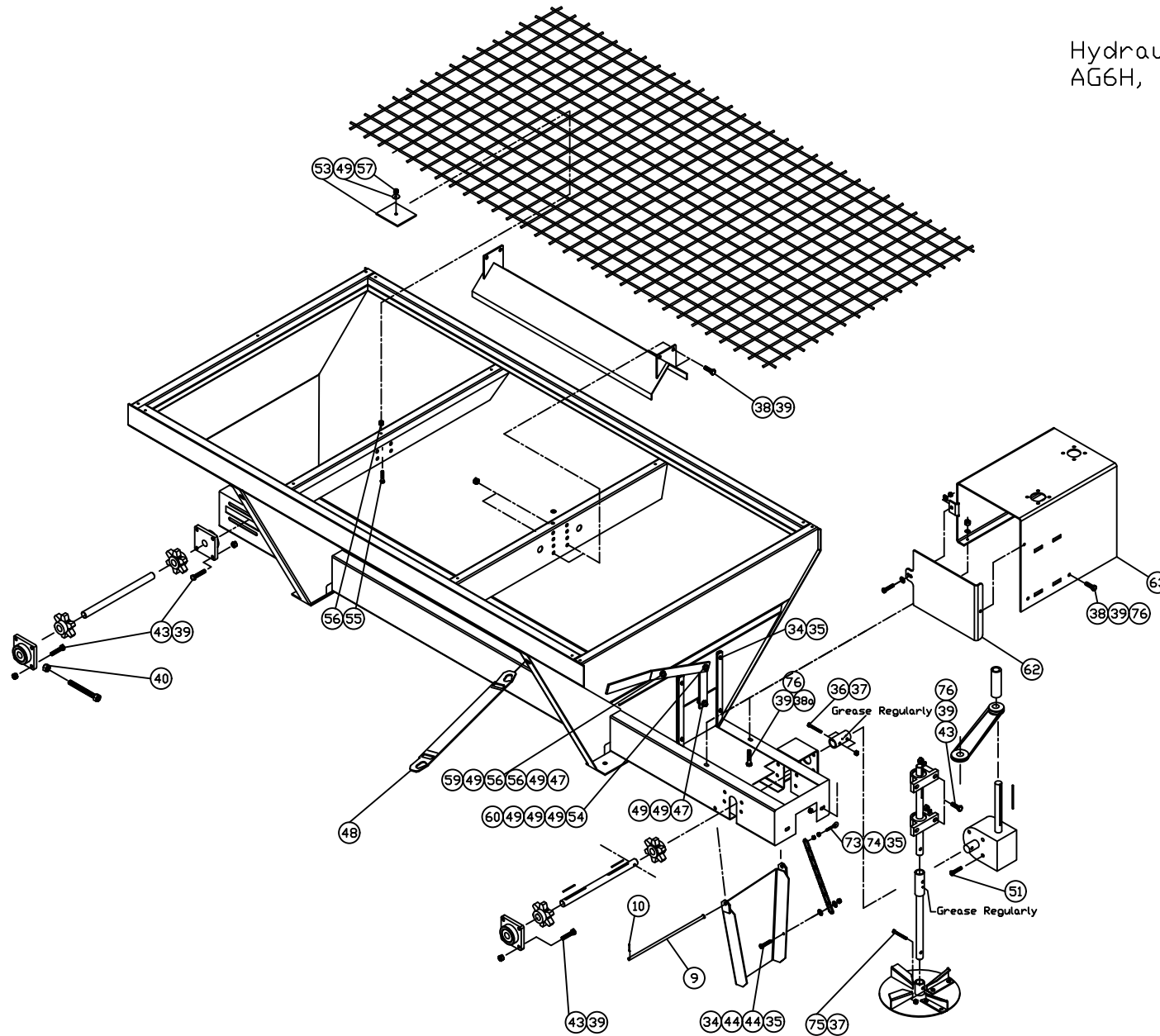

Hydraulic Galvanized Sander AG6H, AG8H, AG10H			
	Part #	Description	Quantity
1	90090-N	Motor / Gearbox Pulley, 2.3"	2
2	90087-N	Gear Box 20:1	1
3	HH-00233-001	¼" x 28 NF Grease Fitting	2
4	HH-00905-013	Spinner Bearing	2
5	RB-889-GA	Spinner Disc	1
6	RB-32996-GA	Chute	1
7	90093-D	Sander, 6', body weldment	1
7a	90094-D	Sander, 8', body weldment	1
7b	90095-D	Sander, 10', body weldment	1
8	90119-B	Drive Coupling	1
9	RC-32854-02-GA	Hinge Pin Weldment	1
10	HH-00020-081	Cotter Pin, 1/8" dia x 3/4" lg	1
11	HH-00859-019	Drive Shaft Bearing, Four Bolt Flange	1
12	RB-872	Drive Sprocket	2
13	HH-00291-101	Key, 1/4" Square x 2 -3/4"	3
14	90120-B	Drive Shaft	1
15	HH-00789-003-14	Chain , 3/16" dia x 14" long	1
16	RB-32992-05	Apron Chain Connecting Pin	1
17	90131-A	Chain Tightener	2
18	HH-00859-014	Idler Shaft Bearing, Four Bolt Flange	2
19	RB-874	Idler Sprocket	2
20	RB-876	Idler Shaft	1
21	RB-32992	Chain Assembly AG6 only	1
21a	RB-32992-02	Chain Assembly AG8 only	1
21b	RB-32992-03	Chain Assembly AG10 only	1

Hydraulic Galvanized Sander AG6H, AG8H, AG10H			
	Part #	Description	Quantity
22	90114-96-C	V Channel, AG8	1
22a	90114-120-C	V Channel, AG10	1
23	90133-N	Screen AG6	1
23a	90134-N	Screen AG 8	1
23b	90135-N	Screen AG10	1
25	90148-N	A31-Gearbox to Spinner Shaft Belt	1
26	HH-00291-104	Gearbox input shaft Key1/4" Square x 7 1/2"	1
28	90124-B	Gate Guide, top plate	2
29	90123-B	Gate Guide, bottom plate	2
30	90126-B	Gate Arm	1
31	90125-A	Gate Middle Link	1
32	90122-A	Gate	1
34	HH-00293-028	Bolt, Hex Head, 5/16" x 1"	5
35	HH-00340-017	Nut, 5/16" Nylon Insert	6
36	HH-00293-055	Bolt, Hex Head, 3/8" UNC x 2 1/2"	2
37	HH-00340-001	Nut 3/8", Nylon Insert	4
38	HH-00293-069	Bolt, Hex Head 7/16" x 1"	6
38a	HH-00971-104	Carriage Bolt, 7/16" x 1"	2
39	HH-00340-002	Hex Nut 7/16" Nylon Insert	24
40	HH-00294-007	5/8" Nut	2
41	90165-B	Bottom Split Shaft Weldment	1
	90167-B	Bottom Split Shaft Extended Weldment	1
42	90162-B	Top Split Shaft (single motor)	1
	90170-B	Top Split Shaft (dual motor)	1
43	HH-00971-106	Carriage Bolt, 7/16 UNC x 1 1/2	16

Hydraulic Galvanized Sander AG6H, AG8H, AG10H			
	Part #	Description	Quantity
44	HH-00341-003	Flat washer 5/16"	2
46	RB-32992-04	Apron Chain Connecting Link	1
47	HH-00340-003	Nut, ½" Nylon Insert, Coarse	1
48	90040-N	Strap	4
49	HH-00341-006	Flat washer 1/2"	8
51	HH-00293-088	Bolt, Hex Head, ½" UNC X 1"	4
52	RB-38759	Mounting Stop Angle (Not Shown)	1
53	90154-A	Screen Hold Down	1
54	HH-00540-004	Nut, ½" Nylon Insert, Fine	3
55	HH-00972-091	Bolt, ½"-20 x 1 3/4" HHCS	1
56	HH-00460-002	Nut, ½" x 20 Hex Nut	3
58	HH-00340-901	1/4" Coarse Lock Nut	8
59	HH-00972-095	Bolt, ½"-20 x 2 1/2"	1
60	HH-00972-090	Bolt, ½"-20 x 1 ½" HHCS	1
61	RB-38770-18	Hydraulic Motor Adapter	1
62	90147-B	Cover Plate	1
63	90145-C	Mounting Plate	1
64	RM-32723	Hydraulic Motor	1
65	HH-00293-049	3/8-16x1" Bolt	1
66	HH-00340-001	3/8"-16 Nylon Insert Locknut	1
67	HH-00341-004	3/8" Flat Washer	2
68	HH-00293-003	¼"-20 x 5/8" HHCS Bolt	8
69	90168-A	Spinner Disc Fin	4
70	RM-32834	"U"- Joint, dual motor (not shown)	1
71	90169-A	Spinner bearing spacer-dual motor (not shown)	1

Hydraulic Galvanized Sander AG6H, AG8H, AG10H			
	Part #	Description	Quantity
72	90170-B	Top spinner shaft, for dual motor (not shown)	1
73	HH-01149-008	5/16" Eye Bolt	1
74	HH-00294-002	5/16" Nut	1
75	HH-01081-054	3/8"- 16x 2 ½ Grade 8 bolt	2
76	HH-00341-005	7/16" Flat Washer	8

Hydraulic Sander Optional Equipment Kits							
	Part Number	Description	90155-M Hydraulic sander kit comes with tank with one motor (hyd)	90156- M Hydraulic sander kit without tank with one motor (hyd)	90157-M Hydraulic sander kit, comes with tank, no control valve with one motor (hyd)	90158-M Hydraulic sander kit, comes with tank & dual motors (no control)	90160 –M Hydraulic sander kit, comes with dual motors, without tank
1	RM-32723	Hydraulic Motor	1	1	1	2	2
2	RC-32890	Hydraulic Tank System (With Flow Divider)	1	-	-	-	-
3	RC-32890-01	Hydraulic Tank System (No Flow Divider)	-	-	1	1	-
4	RB-38759	Mounting Stop Angle	1	1	1	1	1
5	HH-00293-049	Bolt 3/8" 16 x 1 HHCS	4	4	4	8	8
6	HH-00341-004	3/8 Flat washer	4	4	4	8	8
7	HH-00020-081	1/8D x 3/4 L Cotter Pin	1	1	1	1	1
8	HH-00789-003-14	3/16 14" Chain	1	1	1	1	1
9	HH-00291-043	1/4 x 1 1/2 Key Stock	1	1	3	1	2
10	RM-32834	U-Joint	-	-	-	1	1
11	90148-N	Belt A31	1	1	1	-	-
12	90090-N	Pulley 2.3"	2	2	2	-	-
13	HH-00457-007	5/16 Lockwasher	1	1	1	1	1
14	HH-00341-003	5/16 Flat washer	2	2	2	2	2
15	HH-00294-002	5/16-18 Hex Nut	1	1	1	1	1
16	90040-N	Sander Ratchet Strap	4	4	4	4	4
17	HH-00972-091	Bolt 1/2-20x1 3/4 HHCS	4	4	4	-	-
18	HH-00540-004	1/2-20 Nylon Nut	4	4	4	4	4
19	HH-00905-013	Spinner Bearing	2	2	2	2	2

Hydraulic Sander Optional Equipment Kits							
	Part Number	Description	90155-M Hydraulic sander kit comes with tank with one motor (hyd)	90156- M Hydraulic sander kit without tank with one motor (hyd)	90157-M Hydraulic sander kit, comes with tank, no control valve with one motor (hyd)	90158-M Hydraulic sander kit, comes with tank & dual motors (no control)	90160 –M Hydraulic sander kit, comes with dual motors, without tank
20	HH-00340-001	3/8-16 Nylon Insert Nut	2	2	2	2	2
21	HH-00293-055	Bolt 3/8-16x2 ½ HHCS	2	2	2	2	2
22	RB-32996-G	Galvanized Sander Chute	1	1	1	1	1
23	RB-889-G	Galvanized Spinner Disc	1	1	1	1	1
24	RC-32854-02-G	Galvanized Hinge Pin (chute)	1	1	1	1	1
25	HH-00972-090	Bolt ½-20 x 1 ½ HHCS	4	4	4	4	4
26	HH-00457-001	½ Lockwasher	4	4	4	4	4
27	HH-00460-002	½-20 Hex Nut	4	4	4	4	4
28	RB-38770-18	Bushing, ID 1", OD 1.1/2 x 3: long	1	1	1	1	1
29	90169-A	½" Spacer	-	-	-	4	4
30	HH-00972-095	Bolt ½-20 x 2 ¾ HHCS	-	-	-	4	4
31	90162-B	Top split shaft	1	1	1	-	-
32	90170-B	Top split shaft (dual hydraulic motor)	-	-	-	1	1
33	HH-00291-100	¼" x 1.3/8" key stock	-	-	-	-	4
34	HH-00457-004	(WL53) 3/8 lock washer	4	4	4	4	4