

Galvanized Gas Spreader

Models AG6, AG8, AG10
10.5 HP Briggs and Stratton
11 HP Honda

Warning:

Do not exceed GVWR or GAWR with spreader and load. Overloading could result in an accident or damage.

Read this manual and engine owner's manual before installing or operating the spreader.

Sander Warranty

ARCTIC salt/sanding equipment is guaranteed to be free from defects in material or workmanship under normal use and service for 1 (one) year after the date of purchase (except engine – see below).

Arctic Equipment Manufacturing Corporation will replace or repair, at its election, without charge, any part which becomes defective within the period of time described above. Hydraulic motors, pumps, gear reducer, etc. are also covered under warranty for a period of 1 (one) year, with normal use.

Briggs & Stratton engine is covered for 90 (ninety) days under warranty after the date of purchase and Honda engine is covered for 2 (two) years after the date of purchase. Warranty and service of the engine is handled by Honda or Briggs & Stratton dealers.

What is not covered under this warranty is specified below.

In no event shall Arctic Equipment Manufacturing Corporation be liable for claims for loss of use or consequential damages.

This warranty is made only to the original purchaser. There is no other warranty expressed, implied, or statutory.

All parts returned to us, transportation charges prepaid, must be accompanied with a "Return Goods Authorization" number, obtained from the factory. In order to reduce down-time, we will, on your request, send the parts required and you will be billed under the usual terms. A credit will be issued to your account when the parts, in our examination, prove to be defective.

Warranty does not cover:

- Paint or surface coating deterioration, parts such as, drive chain, conveyor chain, belts, controller keypad, bushings, stripped keyways or splines on external shafts, nuts and bolts or tightening nuts and bolts which are considered normal maintenance.
- Problems caused by failure to follow instructions and failure to maintain the product as described in the owner's manual.
- Damage resulting from rust, corrosion, freezing or overheating; failure to maintain proper fluid/lubrication levels, using other than recommended grade and type of lubrication, failure to retighten fasteners, chains and belts.
 - Damage to the product that has been subject to misuse, neglect, accident, or improper installation (mounting), maintenance, care or storage.
- Repairs by an unauthorized person (dealer).
- Damage caused by parts not used in accordance with their intended purpose.
- Damage due to abrasion of wiring harnesses.
- Travel time incurred to and from dealers or suppliers, accommodations, meals, cost of tax, freight to/from dealers, storage charges, environmental charges, solvents, sealants, lubricants.
- Problems caused by accessories and parts that are not supplied by Arctic Equipment.

- Liability for damage to the property, or injury to, or death of any person arising out of the operation, maintenance or use of the covered product.

The customer can register their equipment through Arctic website <http://www.arcticsnowplows.com/warranty> .

Arctic Equipment Manufacturing Corporation reserves the right to change specification without prior notice.

Customer Responsibility

The loaded vehicle, including all after-market accessories, the salt/sanding equipment, passengers, and cargo, **MUST NOT** exceed the gross vehicle weight rating (GAWR), front gross axle weight rating (FGAWR), or rear gross axle weight rating (RGAWR) specified on the Safety Compliance Certification Label located in the driver's side door opening. **It is the operator's responsibility to verify that these ratings are not exceeded.**

To determine the Gross Axle Weights for your vehicle, including all after market accessories, the salt/sanding equipment, passengers, and cargo, take your loaded vehicle to a scale. Place the front wheels of the vehicle on the scale to get the Front Gross Axle Weights (FGAW). To get the Rear Gross Axle Weights (RGAW), place the back wheels of the vehicle on the scale.

Disclaimer Notice

Arctic Equipment Manufacturing Corporation (Arctic) does not assume liability for damage to your motor vehicle resulting from the attachment or use of an Arctic salt/sanding equipment. The purchaser assumes all vehicle risk associated with the attachment and operation of this salt/sanding equipment.

The added weight may impair the operation and control of your vehicle. Additional equipment may be necessary before installing salt/sanding equipment. Please consult your vehicle dealer prior to the purchase and installation of the salt/sanding equipment.

Ordering parts

Delays and errors can be eliminated if ordering instructions are followed correctly.

1. Place orders direct with Arctic Equipment Manufacturing or nearest dealer.
2. State company name, address, and postal/zip code.
3. Give exact model and serial number of the machine (stamped on the unit identification plate).
4. Furnish part number, description and quantities required.
5. Print or type order clearly.
6. Give specific shipping instructions.

Spreader equipped with gas engine

WARNING

- Empty and clean the hopper and wash off all external surfaces after each use.
- Do not overload vehicle. Check vehicle's load rating certification sticker for maximum vehicle capacity.
- Do not exceed GVWR or GAWR with spreader and load. Overloading could result in an accident or damage.
- Turn spreader OFF before filling, adjusting, cleaning, servicing or performing maintenance.
- Servicing the sander without special tools and knowledge could result in personal injury. See an authorized Arctic dealer for service.
- Driver to keep bystanders minimum of 25 feet away from operating spreader.
- Before operating the spreader, verify all safety guards are in place.
- Before servicing the spreader, wait for conveyor or spinner to stop, and then lock out power.
- Avoid touching hot surfaces such as the engine and exhaust pipe.
- Do not climb into or ride on spreader.
- Turn off engine and allow it to cool before filling gas tank.
- DO NOT smoke or use open flame within 25 feet of spreader.
- Allow spilled gas to evaporate completely before starting engine.
- Gasoline engine produces poisonous gases while running. DO NOT operate in an enclosed area.
- Gasoline engine has hot and moving parts that can cause injury.
- Use care when working with or near the gasoline engine and its parts.
- Inspect ratchet straps and tie down bolts before travelling. Parts that are loose, broken, missing or plainly worn must be tightened or replaced immediately.
- Shut off engine when not in use, even for short periods of time, to avoid damage to equipment or property.
- Do not leave unused material in hopper. Material can freeze or solidify, causing unit to not work properly. Empty and clean after each use.
- To remove the sander, the unit must be empty. Do not stand close to the sander when it is being lifted. Keep a safe distance away.

Material Density

(lb per cubic yd.)

Fine Salt – Dry 1400

Coarse Salt – Dry 1300

Coarse Sand – Dry 2800

Coarse Sand – Wet 3300

Operation

These models are powered by a 10.5 H.P. Briggs & Stratton Engine or 11 HP Honda Engine. In order to provide a smooth transmission of power, the units are equipped with a heavy duty electrical clutch (picture 14). The gear box (speed reducer) output shaft is what actually drives

the conveyor. A single V-belt connects Engine and gear box, and the gear box with the spinner shaft (picture 6, 14 & 15).

The amount of sand and/or salt that is discharged is dependant on two factors. One is the engine RPM which is controlled by a throttle. An increase in engine RPM not only increases the discharge rate but the width of spread pattern as well. The other factor that affects the discharge rate, is the gate opening. Obviously, as the size of the opening increases so will the discharge rate. A cab mounted switch activates the electric throttle, starter and clutch.

Spreader Installation

The AG6 spreader is designed for installation in a 6'8" pickup truck bed. The AG8 is designed for installation in an 8' pickup truck bed. The AG10 spreader is designed for 10' dump truck or flat deck truck. Follow the steps below to install your unit in your vehicle.

- a) Slide spreader into position and secure with the ratchet straps into the cargo tie downs of the truck (pictures # 3 and #4)
- b) Bolt mounting angle bracket to spreader, then bolt it to the back of the truck using ½" bolt. (Picture #2)
- c) Install the sand chute using the required pivoting/fastening components. (Picture #12)
- d) Assemble the spinner assembly (split shafts), as shown in the assembly drawing in this manual, using the appropriate components. (Picture #5, 11 and 12)
- e) Position the spinner disc at the desired height and tighten set screws.

You may change the spinner disc height. Using the hole in the spinner disc hub as a guide, drill a hole through the shaft, for the mounting bolt. Cut off any excess length from the shaft and install the spinner disc.

- f) Position spinner shaft so it is sitting true (vertical and horizontal) with enough tension on the spinner belt. (Picture #5 & 6).
- g) Check that belts are aligned on the pulleys (pictures #6, 14, 15) and adjust (if necessary).
- h) Apply grease to: split shaft assembly nipples (picture #5), Spinner shaft bearings (picture #11), drive bearing (picture #7 & 12), idler bearings (picture #8).
Note: Liberally spread grease on the apron chain tensioning bolts (picture #8) to allow for easy tightening at a later date.
- i) Check and add Oil before Starting and Running (motors are shipped with a minimal amount of oil in them) Briggs and Stratton Require SAE 30, Honda requires 5W30.
- j) Protect wiring harness from rubbing on sharp / hot surfaces. Use loom and zip ties where ever possible (picture #2 & 9).

k) For wiring information see page with wiring instructions.

l) Optional - Refer to Hitch Mounted Spinner Shaft Guard installation instructions to further protect your sander from damage.

Clutch Pre-run setup

Clutches must be burnished before operation. We recommend the clutches be engaged/disengaged a few times to break them in before being placed under load.

1. Run the engine at 50% throttle.
 2. Engage and disengage the clutch 25 times 10 seconds ON and 10 seconds OFF.
 3. Run the engine at 75% throttle,
 4. Engage and disengage the clutch 25 times 10 seconds ON and 10 seconds OFF.
- It is recommended 15-20 ft-lbs of torque on pulley assembly screws

Burnishing procedure **must be done on a brand new unit before it is loaded with material.**

Never perform the burnishing procedure while drive is loaded.

Starting Up

Check oil level. Oil must be added prior to operation. (Briggs and Stratton requires SAE 30, Honda calls for 5W-30)

Reasonable precautions should be taken to avoid overloads in the early stage of running.

Temperature rise on the initial run will be higher than the temperature eventually reached after the gear is fully run in.

Maintenance

Shut off power before inspection. The oil level, in the worm gear unit should be checked at least once a month. (To check oil level, undo set screw located at the three o'clock position in Picture #1. Oil should be seen just below this level)

To maintain free ventilation of the unit, the breather hole in the filler plug (air-vent on top of unit Picture #1) should be kept clear at all times. Inspect regularly the set screw and reducer mounting bolts for tightness as loose fasteners can cause misalignment and excessive wear.

Changing Lubricant

- Every year gear box should be drained, flushed and refilled with proper oil.
- Never mix two different types of oil. Be sure to drain and wash before using another type of oil.

Selection Of Lubricant

Our gearboxes are normally filled up with oil of S.A.E. grade 80W90. Where a wide temperature range is expected, the synthetic oil MOBIL SHC 634 is recommended. Synthetic lubricants permit extended life time between drains. This is due to the increased resistance to thermal degradation or oxidation.

Conveyor Chain Lubrication

When you receive your new spreader, it is not necessary to lubricate the chain. However, when you store the machine at the end of the season, it is crucial to lubricate it properly to prevent chain links from seizing. One way is to remove the chain and store it in a lubricant.

Electric System

When you install the spreader, it is very important to put dielectric grease in every connection. Also, during the season, make sure to inspect the connectors regularly and add dielectric grease when needed. Also, when the season is over, all connections need to be well cleaned and lubricated with dielectric grease to prevent corrosion and rust during the storage period.

Before Operating

- 1) Engine oil and speed reducer oil level.
- 2) Grease all lubrication points.
- 3) Ensure all belts are tight.
- 4) Ensure that the conveyor chain is dragging for one foot on the bottom return channel, of the spreader. (Do not over tighten the chain).
- 5) Ratchet straps are in good condition, and all bolts are tight.

Maintenance Inspection

Daily Inspection and Lubrication

- a) Check gearbox oil level. It should be filled to the oil filler plug (Picture #1).
- b) Check engine oil level with dipstick (also check gas).
- c) Lubricate the following grease nipples:
 - 1) One on each conveyor idler shaft bearing (Picture #8, Item #27 on Parts List)
 - 2) One on the drive shaft bearing (Picture # 7, Item #19 on Parts List)
 - 3) One on each (2) spinner shaft bearing (Picture #11, Item #12 on Parts List)

- 4) One on drive shaft coupling (Picture #13, Item #16 on Parts List)
- 5) One on split shaft coupling (Picture #5)

- d) It is advisable to clean the air filter element. It can be easily washed out and reused. At this time, it would be wise to check the drive belts for any appreciable wear.

- e) Apply dielectric grease in any electric connections periodically.

- f) Inspect ratchet straps and tie down bolts. Parts that are loose, broken, missing or plainly worn must be tightened or replaced immediately.

- g) After every use, empty and clean the hopper and wash off all external surfaces.

- h) Tighten conveyor chain if required till the point when the center path of the chain nearly touch the base, making an arc shaped path visible from side view, oil conveyor chain, if needed for smooth movement of the load.

- i) Remove any trapped or frozen substance that can cause obstruction to the movement of conveyor chain.



Yearly Inspection

- a) At the end of the operating season, the unit should be thoroughly cleaned and lubricated (see daily inspection and lubrication). The conveyor chain (picture #10) could be removed and stored in motor oil or grease. These preventative measures should prevent premature rusting of the unit. Grease bolts on the chain tighteners (picture #8).

- b) At this time or before the start of the next season, it is wise to check all drive components for appreciable wear. Any components which are questionable should be replaced now. Check that all bolts are tight and ratchet straps are in good condition. This short and simple check will avoid down time during the operating season.

- c) Change the gear box oil (Picture #1).

- d) Parts that are loose, broken, missing or plainly worn must be tightened or replaced immediately

TORQUE CHART (FT. LB.)		
SIZE	GRADE 5 BOLT 	GRADE 8 BOLT 
$\frac{1}{4}$ - 28	8	11
$\frac{5}{16}$ - 24	15	22
$\frac{3}{8}$ - 24	28	40
$\frac{7}{16}$ - 20	44	63
$\frac{1}{2}$ - 20	69	97
$\frac{5}{8}$ - 18	138	195
$\frac{3}{4}$ - 16	241	341
<u>Note:</u> Torque values are for plated bolts only		

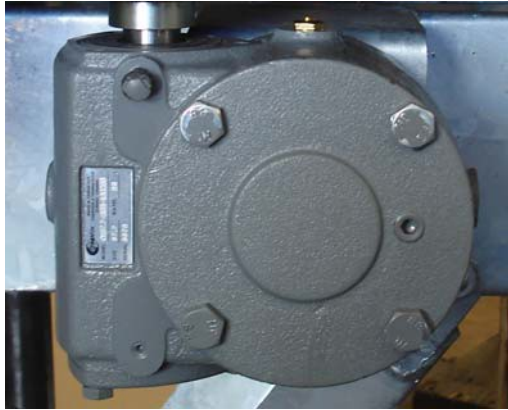

Picture #1



Picture #2



Picture #3



Picture #4



Picture #5



Picture #6



Picture #7



Picture #8



Picture #9



Picture #10



Picture #11

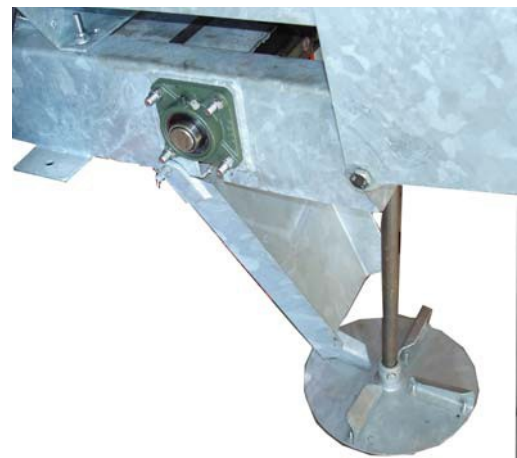

Picture #12

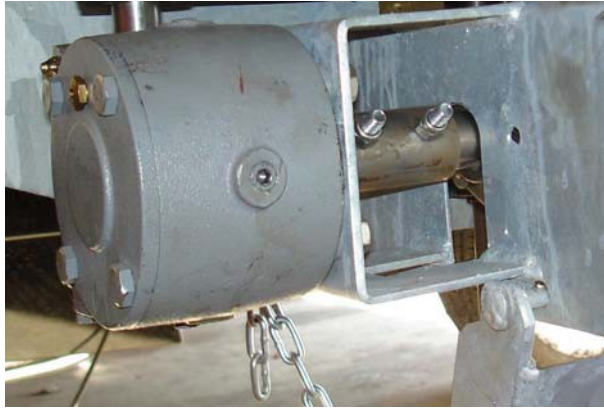

Picture # 13



Picture # 14



Optional Spinner Guard



Picture # 15

Installation of electrical throttle for Briggs & Stratton Engine

Electrical Throttle for B&S Engine RC-38880			
Item	Part#	Description	Qty.
1	1411907	Throttle motor	1
2	1411910	Throttle pin Assembly	1
3	HH-00013-074	#8-32 x 3/4" Pan Head Machine Screw	3
4	HH-00340-019	#8 Locknut	3
5	90069-A	Throttle mounting bracket	1

Note: Mounting bracket needs to be installed using engine mounting bolts.

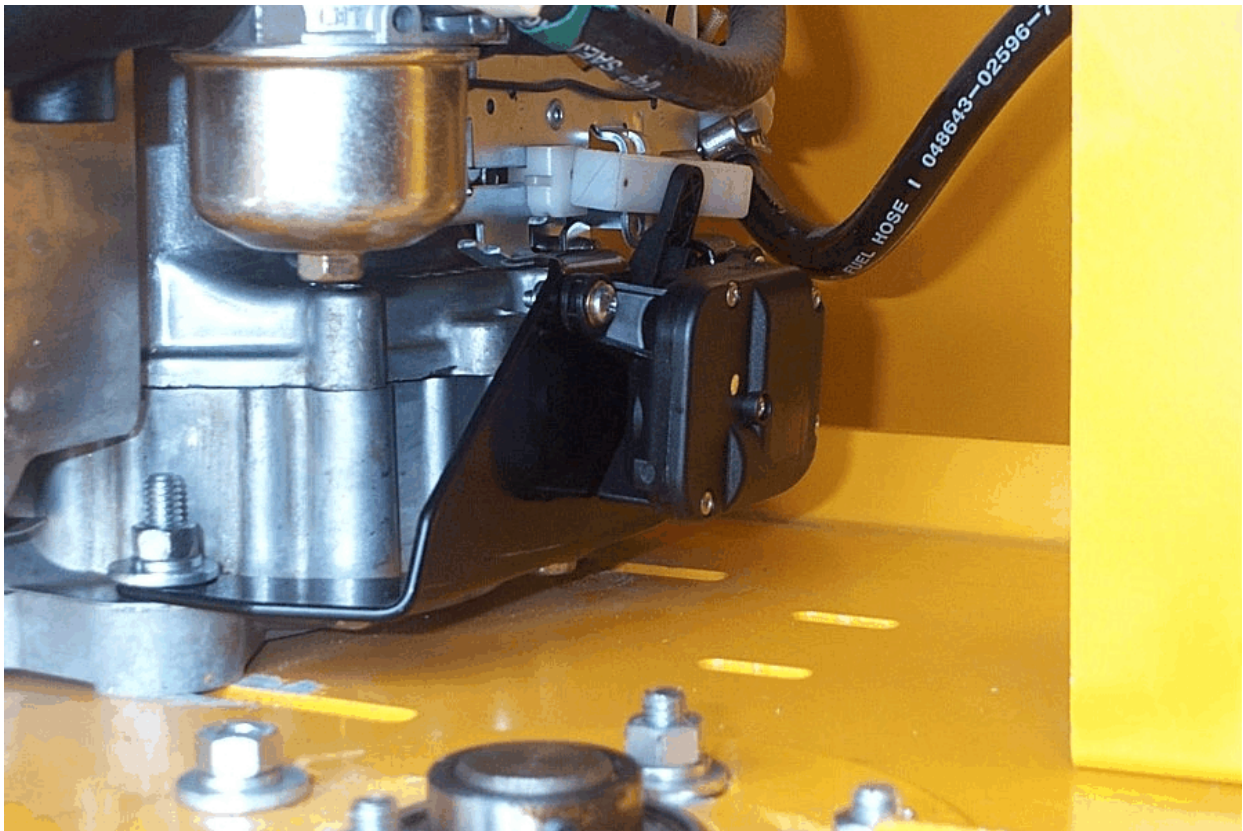

Electrical Throttle Kit for Honda Engine RC-38880-01

Item	Part#	Description	Qty.
1	1411907	Throttle motor	1
2	90086-A	Throttle mounting bracket	1
3	HH-00013-073	#8-32 x 5/8" Pan Head Machine Screw	4
4	HH-00340-019	#8 Locknut	4
5	90045-N	Retainer	1
6	90076-A	Harness	1
7	90046-M	Handle	1
8	90048-N	2/56 Screw	3
9	90049-N	2/56 Nut	3
10	90050-M	Extension Bracket	1

Installation of electrical throttle for Honda Engine

1. Install throttle motor (1) to the throttle mounting bracket (2) using four #8 screws and nuts (3)(4). (For correct orientation of the throttle motor (1) see pictures #1, #2, and #3)
2. Remove two bolts that hold gas tank. Install throttle mounting bracket (2) between engine body and gas tank. Secure throttle mounting bracket (2) and gas tank using existing tank bolts.
3. Using two 2/56 screws and nuts (8)(9) secure extension bracket (10) to the gas engine bracket (See picture#2).
4. Install the handle (7) on the throttle motor arm (1). Secure the handle (7) to the throttle motor arm using the retainer (5). (See picture #3)
5. Attach handle (7) to the extension bracket (10) using one 2/56 screw and nut (8)(9). (See picture #2)
6. One end of the harness (6) attach to the ground (engine bolt) and second attach to Honda engine light wire. (See picture #4)



Picture #1

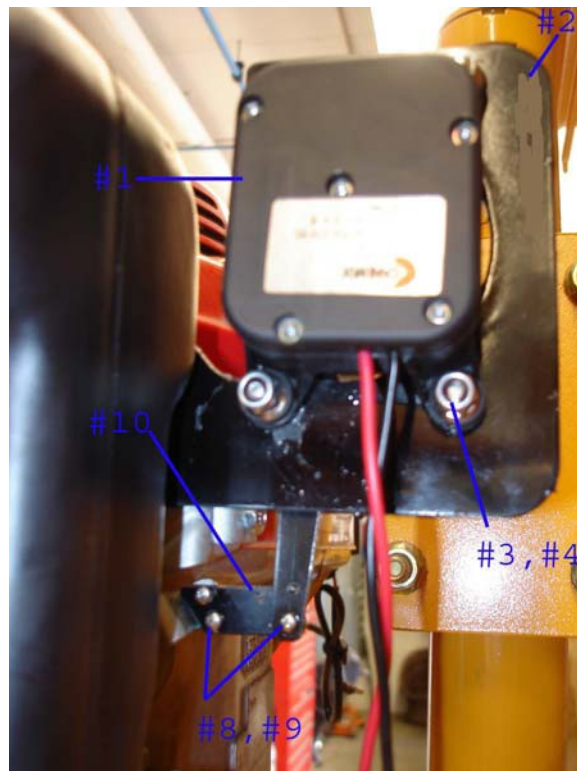

Picture #2

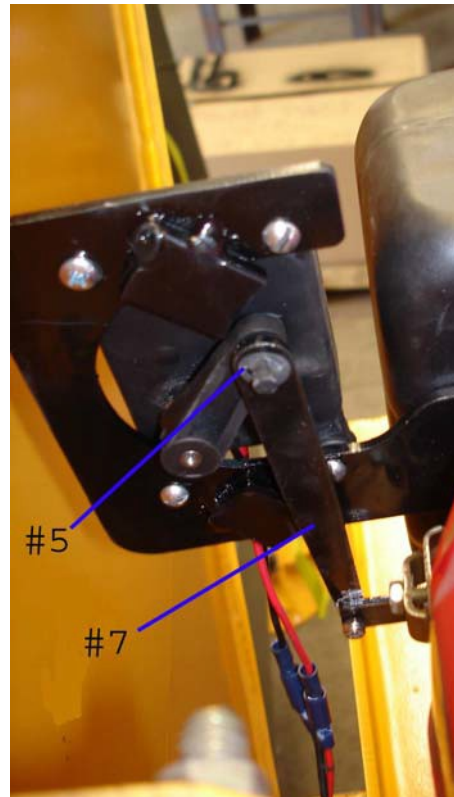

Picture #3



Picture #4

Galvanized Sander
AG6, AG8 & AG10
with gas engine

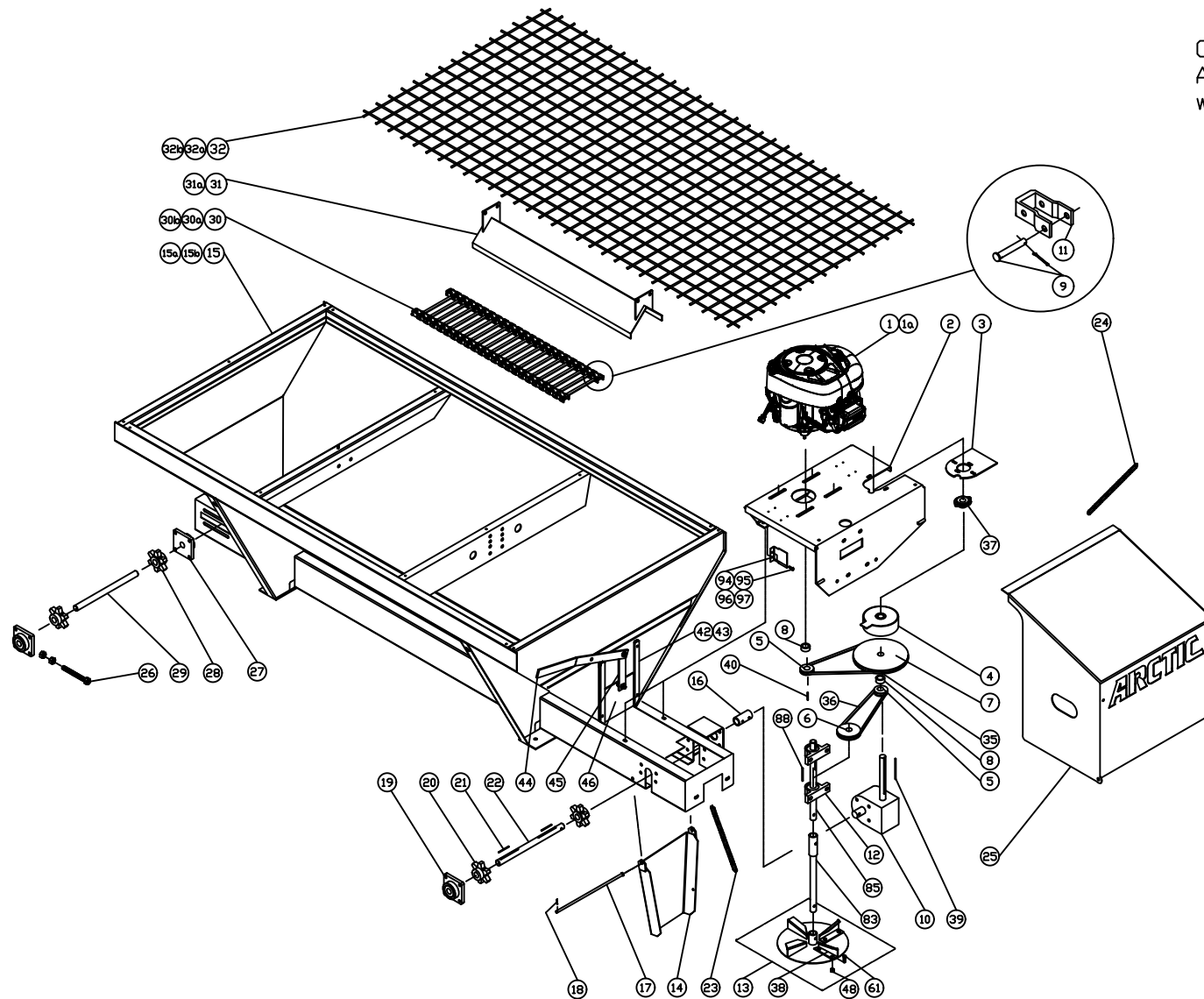

Galvanized Sander
AG6, AG8 & AG10
with gas engine

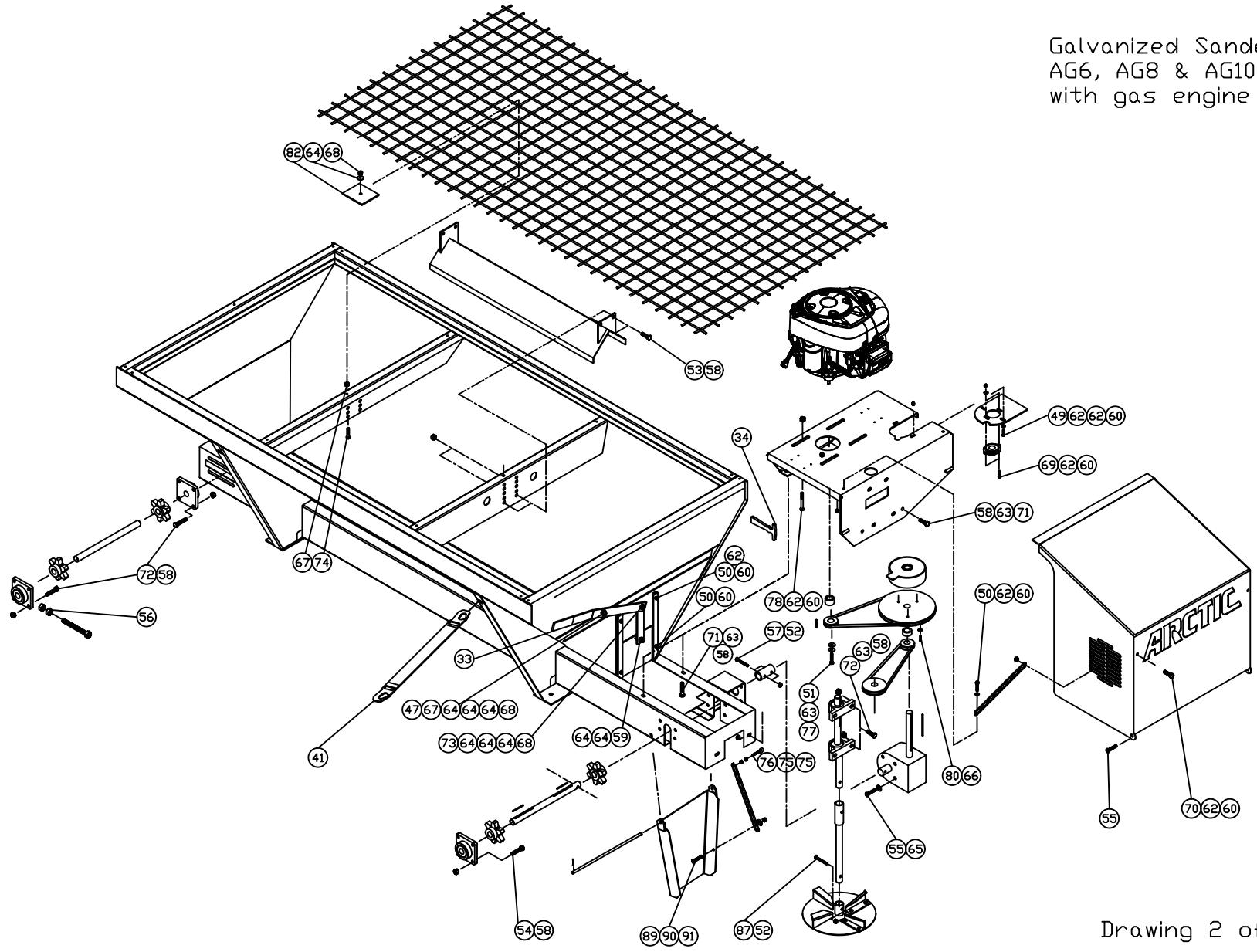

WIRING DIAGRAM FOR 8', 10' AND DUMP TRUCK SAND SPREADER

1. The control box 90020-A is to be installed under the dash.
2. Drill hole 1 1/2" in firewall of the truck to attach harness 90028-A to harness 90020-A.
The cable with 3 wires goes under the hood to be attached to the solenoid (installed under hood of the truck).
Second part of harness goes to the back of vehicle. A cable clip is provided at the end of harness so that it can be secured to the truck.
3. Attach the harness 90029-A to the harness 90028-A. Tie harness 90029-A to the sander. End of the harness is attached to the motor, the clutch and the throttle as shown on drawing.
4. Harnesses 90028-A and 90029-A have "dummy" plugs to be attached when harnesses are not attached to each other for weather protection.
5. Note: If electric throttle runs backwards switch wires 1 and 2 as shown.
6. Red wire on power cable 90030-A is to be attached to solenoid and black wire to be attached to the vehicle frame (ground). Second power cable 90031-A is attached to cable 90030-A, red wire is attached to motor and black wire is attached to engine mounting plate.

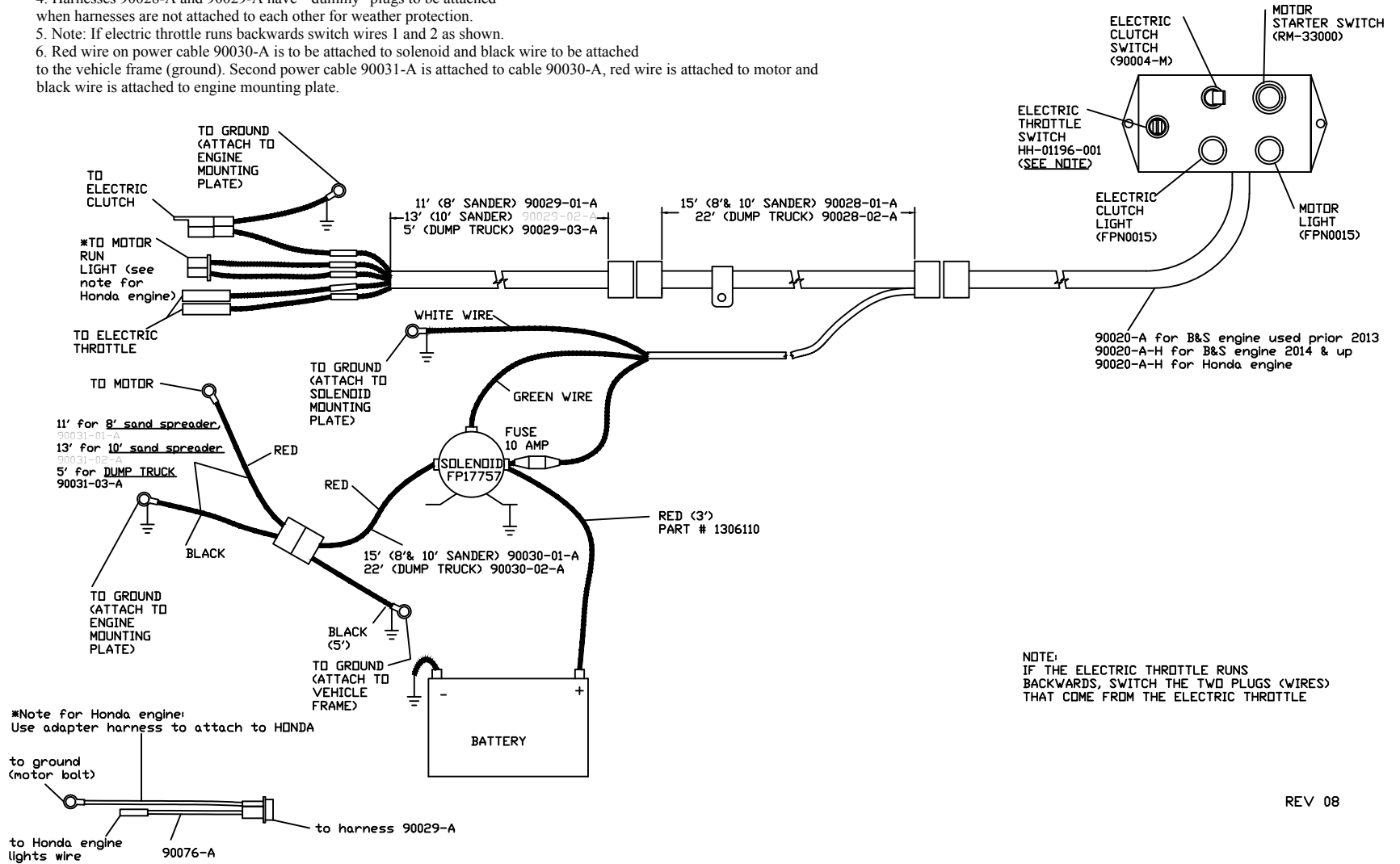

Top View

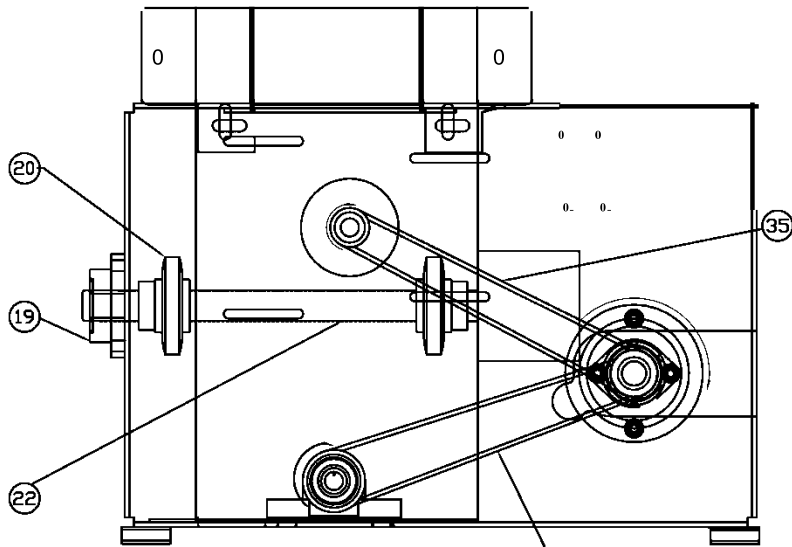

Drive detail for sander with gas engine

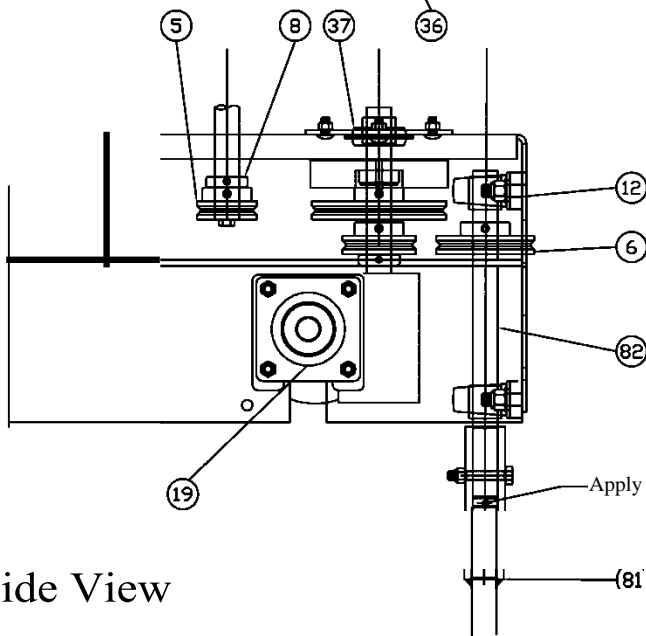

Side View

Back View

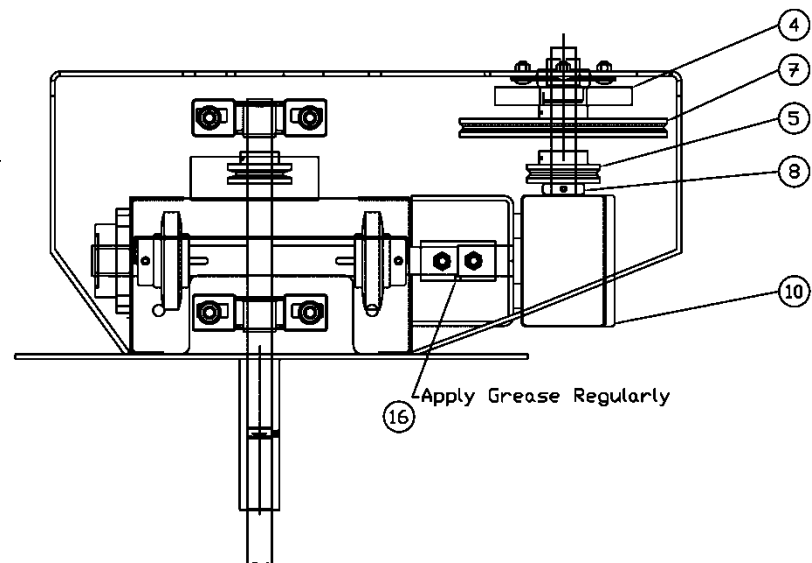

Galvanized Sander AG6, AG8, AG10 With Gas Engine R04			
	Part #	Description	Quantity
1	RM-33002-10.5HP	Gas Engine, 10.5 HP, Briggs & Stratton	1
1a	RM-33002-H	Gas Engine, 11HP, Honda	1
2	90117-C	Mounting Plate	1
3	90118-A	Top Bearing Plate	1
4	90089-M	Electric Clutch	1
5	90090-N	Pulley, 2.3" , Motor & Gearbox –Spinner Shaft	2
6	90091-N	Pulley, 3.5" , Spinner Shaft	1
7	90092-N	Pulley, 9.3" , Clutch	1
8	90140-N	Spacer, 0.50"	2
9	RB-32992-05	Chain Connecting Pin	1
10	90087-N	Gear Box 20:1	1
11	RB-32992-04	Chain Connecting Link	1
12	HH-00905-013	Spinner Bearing	2
13	RB-889	Spinner Disc	1
14	RB-32996	Chute	1
15	90093-D	Sander, 6', body weldment	1
15a	90094-D	Sander, 8', body weldment	1
15b	90095-D	Sander, 10', body weldment	1
16	90119-B	Drive Coupling	1
17	RC-32854-02	Hinge Pin for sander chute	1
18	HH-00020-081	Cotter Pin, 1/8" dia x 3/4" long	1
19	HH-00859-019	Drive Shaft Bearing, Four Bolt Flange	1
20	RB-872	Drive Sprocket	2
21	HH-00291-101	Key, 1/4" Square x 2 -3/4"	2
22	90120-B	Drive Shaft	1
23	HH-00789-003-14	Chain , 3/16" dia x 14" long	1
24	HH-00789-003-20	Chain , 3/16" dia x 20" long	2
25	90128-D	Hood	1
26	90131-A	Bolt weldment for idler bearing (chain tightener)	2
27	HH-00859-014	Idler Shaft Bearing, Four Bolt Flange	2
28	RB-874	Idler Sprocket	2
29	RB-876	Idler Shaft	1
30	RB-32992	Chain, AG6 only	1
30a	RB-32992-02	Chain, AG8 only	1
30b	RB-32992-03	Chain, AG10 only	1
31	90114-96-C	V Channel, AG8	1
31a	90114-120-C	V Channel, AG10	1
32	90133-N	Screen AG6	1
32a	90134-N	Screen AG 8	1
32b	90135-N	Screen AG10	1
33	90252-N	Rubber Grip for Gate Handle	

Galvanized Sander AG6, AG8, AG10 With Gas Engine R04			
	Part #	Description	Quantity
34	HH-00857-006	Hood Latch	2
34a	HH-00013-073	#8 x 5/8" Screw	4
34b	HH-00340-019	#8 Lock nut	4
35	90130-N	Belt, Gas Engine to Clutch, A42	1
36	90129-N	Belt, Gearbox to Spinner Shaft, A33	1
37	HH-00960-009	Bearing (to support gear box input shaft)	1
38	90168-A	Replaceable Spinner Disc Fin – part of RB-889	1
39	HH-00291-011	Gearbox input shaft Key 1/4" Square x 3.5"	1
40	HH-00291-102	Motor pulley Key 1/4" Square x 1.50"	1
41	90040-N	Strap	4
42	90124-B	Gate Guide, top plate	2
43	90123-B	Gate Guide, bottom plate	2
44	90126-B	Gate Arm	1
45	90125-A	Gate Middle Link	1
46	90122-A	Gate	1
47	55600-004	1/2"-20 UNF x 2" HHCS	1
48	HH-00293-003	1/4" -20 UNC x 5/8" HHCS	8
49	HH-00293-028	5/16"-18 UNC x 1" HHCS	2
50	HH-00293-029	5/16" -18 UNC x 1 1/4" HHCS	6
51	HH-01169-069	7/16"-20 UNF x 1" HHCS	1
52	HH-00293-055	3/8" -16 UNC x 2 1/2" HHCS	2
53	HH-00293-069	7/16"-14 UNC x 1" HHCS	4
54	HH-00293-072	7/16" -14 UNC x 1 3/4" HHCS	4
55	HH-00293-088	1/2"- 13 UNC x 1" HHCS	6
56	HH-00294-007	5/8" -11 UNC Nut	4
57	HH-00340-001	3/8"-16 UNC Lock Nut	2
58	HH-00340-002	7/16"-14 UNC Lock Nut	24
59	HH-00340-003	1/2"-13 UNC Lock Nut	1
60	HH-00340-017	5/16" – 18 UNC Lock Nut	16
61	HH-00340-901	1/4" – 20 UNC Lock Nut	8
62	HH-00341-003	5/16" Flat Washer	13
63	HH-00341-005	7/16" Flat Washer	9
64	HH-00341-006	1/2" Flat Washer	9
65	HH-00457-001	1/2" Lock Washer	4
66	HH-00342-002	5/16" Lock Washer (Internal Tooth Lock)	3
67	HH-00460-002	1/2" – 20 UNF Nut	2
68	HH-00540-004	1/2" – 20 UNF Lock Nut	3
69	HH-00971-043	5/16" -18 UNC x 1" Carriage Bolt	2
70	HH-00971-044	5/16" -18 UNC x 1.25" Carriage Bolt	2
71	HH-00971-104	7/16" -14 UNC x 1" Carriage Bolt	4
72	HH-00971-106	7/16" -14 UNC x 1.5" Carriage Bolt	12

Galvanized Sander AG6, AG8, AG10 With Gas Engine R04			
	Part #	Description	Quantity
73	HH-00972-090	½" -20 UNF x 1.5" HHCS	1
74	HH-00972-091	½" -20 UNF x 1.75" HHCS	1
75	HH-00294-002	5/16"-18 Hex Nut	2
76	HH-01149-008	5/16"-18 x 3.75" Eyebolt	1
77	HH-00457-011	7/16" Lock Washer	1
78	HH-00293-032	5/16"-18 UNC x 2" HHCS	4
79	HH-00972-028	5/16"-24 UNF x 1" HHCS (For Honda Only)	2
80	HH-00356-097	5/16"-18 UNC x 3/4" SHCS	3
81	RB-38759	Mounting Stop Angle (Not Shown)	1
82	90154-A	Plate, Poly, Screen Hold Down	1
83	90165-B	Bottom Split Spinner Shaft	1
84	90167-B	Bottom Split Spinner Shaft Extended	1
85	90162-B	Top Spinner Split Shaft	1
86	HH-00233-001	¼-28 Grease fitting	5
87	HH-01081-054	3/8 16x 2 ½ Grade 8 bolt	2
88	HH-00291-101	Spinner Shaft Pulley Key 1/4" Square x 2.75"	1
89	HH-00293-028	5/16" -18 UNC x 1"	1
90	HH-00341-003	5/16" Flat washer	1
91	HH-00340-017	5/16" -18 UNC Hex locknut	1
92	HH-00972-090	½"-20 UNF x1.5" HHCS	4
93	HH-00540-004	½"-20 UNF Lock Nut	4
94	90115-03-B	Plate, Sand Guide	2
95	HH-00294-003	3/8" Nut	4
96	HH-00293-049	3/8" x 1" Bolt	4
97	HH-00457-004	3/8" Lock Washer	4