

Hitch Mounted Electric Salter

HM8P Hitch Mount Salter 8 cu. ft.

Warning:

Do not exceed GVWR or GAWR with hitch mount Salter and load. Overloading could result in an accident or damage. Check vehicle (truck) owner's manual for maximum tongue weight capacity for your hitch mount receiver. Do not exceed hitch mount Salter (Salter) capacity. Read this manual before installing or operating the Salter

Hitch Mount Salter (Salter) Warranty

ARCTIC salting equipment is guaranteed to be free from defects in material or workmanship under normal use and service for 1 (one) year after the date of purchase. Arctic Equipment Manufacturing Corporation will replace or repair, at its election, without charge, any part which becomes defective within the period of time described above.

See specifications below what is not covered under warranty.

In no event shall Arctic Equipment Manufacturing Corporation (Arctic) be liable for claims for loss of use or consequential damages.

This warranty is made only to the original purchaser. There is no other warranty expressed, implied, or statutory.

All parts returned to us, transportation charges prepaid, must be accompanied with a "Return Goods Authorization" number, obtained from the factory. Arctic Equipment Manufacturing Corporation reserves the right to change specification without prior notice.

Specifics not considered under warranty

Certain types of damage can occur, which cannot be attributed to defects in material and/or warranty, but rather as the owner's responsibility.

These conditions include but are not limited to the following items. Damage resulting from:

1. Accident, abuse, or neglect.
2. Repairs by an unauthorized person.
3. Damage caused by improper mounting or conditions on units not mounted by factory.
4. Improper maintenance or storage of equipment.
5. Improper greasing of electrical components.

Disclaimer notice

Arctic Equipment Manufacturing Corporation (Arctic) does not assume liability for damage to your motor vehicle resulting from the attachment or use of our equipment. The purchaser assumes all vehicle risk associated with the attachment and operation of this equipment.

The added weight may impair the operation and control of your vehicle. Additional equipment may be necessary before installing Salter. Please consult your vehicle dealers prior to the purchase and installation of the salting equipment.

Safety and warnings

WARNING:

- Do not exceed the gross vehicle weight ratings (GVWR), front gross axle weight rating (FGAWR) or rear gross axle weight rating (RGAWR) with Salter and load. Overloading could result in an accident or damage. Do not exceed Hitch Mount Capacity on truck Hitch Mount. Check vehicle (truck) owner's manual for maximum tongue weight capacity for trucks hitch mount receiver. Do not exceed weight capacity of hitch mount Salter.

Hitch Mount Salter weight: HM8P – 155lb

Weight capacity for HM8P is 450 lb

It is strongly recommended to load spreader at the job site and to do dispense all of the materials at the job site.

Note: Arctic recommends using only bagged salt.

Before attempting any procedure in this book, read and understand all the safety information contained in this section. In addition, ensure all individuals working with you are also familiar with these safety precautions.

For your safety, warning and information decals have been placed on this product to remind the operator to take safety precautions. It is important that these decals are in place and are legible before operation begins. New decals can be obtained from Arctic Equipment Manufacturing or your local dealer.

Remember, it is the owner's responsibility for communicating information on the safe use and proper maintenance of this equipment. The careful operator is the best operator. Most accidents are caused by human error. Certain precautions must be observed to prevent the possibility of injury to operator or bystanders and/or damage to equipment.

- Driver to keep bystanders a minimum of 25 feet away when operating Salter.
- Servicing the Salter without special tools and knowledge could result in personal injury. See an authorized Arctic dealer for service.
- Before servicing the Salter, make sure power is disconnected and locked out.
- Do not climb into or ride on Salter.
- Do not allow hands, hair, or clothing to get near any moving parts such as spinner, auger etc.

- Do not wear loose clothing when working on the vehicle. These things can catch on moving parts or cause an electrical short circuit that could result in personal injury. Do not wear wrist watches, rings or other jewellery when working on the vehicle or individual equipment.
- Do not allow unauthorized persons to operate this unit.
- Do not work on a vehicle without having a fully serviced fire extinguisher available. (Dry chemical unit specified for gasoline, chemical or electrical fires).
- Do not smoke while working on the vehicle. Gasoline and battery acid vapours are extremely flammable and explosive.
- Do not alter the Salter, or any part without written approval of Arctic Equipment Manufacturing Corporation.
- Do not leave unused material in hopper. Material can freeze or solidify, causing unit to not work properly. Empty and clean after each use.**
- Inspect the Salter periodically for defects. Parts that are loose, broken, missing, or plainly worn must be tightened or replaced immediately.
- Check the job site for terrain hazards, obstructions, and people. Check surrounding area for hazardous obstacles before operating this unit.
- Wear safety goggles when working on the vehicle to protect your eyes from battery acid, gasoline, and dust or dirt from flying off of moving engine parts.
- Be aware of and avoid contact with hot surfaces such as engine, radiator, and hoses.
- Wear safety glasses with side shields when striking metal against metal. Failure to heed could result in injury to the eye(s) or other parts of the body.
- Be sure that the Salter is properly attached before moving the vehicle.

Specification

- ½ HP, 20-amp electric motor 12 Volt D/C
- In Cab Variable Speed Controller is used for precise spreading. It features on/off/auto switch for both the controller & vibrator, blast button and a conveyor speed dial.
- Variable height mounting receiver allows for maximum clearance
- The motor is mounted and protected on both sides by ¼” steel plating.
- Wheels mounted to aid in removal, installation, and storage (use only with empty Salter)

- Quiet electric-drive system
- Low maintenance, direct drive system eliminates unnecessary belts and pulleys.

Spreader Installation

Warning! The Salter is a large and heavy unit that should be installed with the help of an assistant. Please read and understand all instructions prior to starting the job.

The Electric Hitch Mount spreader is designed for installation on most vehicles that are capable of having a class III and class IV hitch receiver hitch. Prior to installation, be certain that the vehicle receiver is in good working order and is fastened to the vehicle securely. Be sure to check vehicle (truck) owner's manual for maximum tongue weight capacity for trucks hitch mount receiver. Do not exceed Hitch Mount Capacity on truck Hitch Mount.

Follow the steps below to install the unit on your vehicle.

- a) Remove the Salter and all components from packaging and familiarize yourself with them.
- b) Clean and remove any debris or build up in the vehicle receiver. It may be helpful to apply grease inside of the receiver to aid in installation / removal.
- c) Locate and mount the hitch plate to the sander body with four ½" bolts and nuts. (The tube on the hitch plate is offset to allow for height options). Tighten bolts.
- d) With the help of an assistant, lift the Salter up and slide the tube into the receiver on the vehicle. Align the holes, insert the pin and secure with the locking pin.
- e) On each side of the Salter at the top, there is a hole for straps to minimize Salter movement. Take the ratchet straps and hook one end to the hole. The other end will go to the cargo hold downs inside box or the stake pocket. Tighten evenly until snug.
- f) The Salter when installed blocks the license plate. It should be removed and mounted on the sander.
- g) Remember! When the Salter is installed, it will stick out an extra 2.5 feet away from the bumper and may not be visible over the tailgate when you are reversing. Use caution when reversing with Salter on truck.

Electrical Installation

- h) Lay the wiring harness out and start to route it from the back of the vehicle to the front coming up the length of the driver's side of the frame (back portion of the harness will have a two pronged rubber plug that can be attached in a location on the bumper that allows for easy access to plug and unplug unit and does not interfere with any other accessories) and coiling excess up between the firewall and Drivers side fender.
- i) Locate a safe spot without interference on the firewall on the driver's side to drill a 1" diameter hole for the wiring harness to go into the cab. Note: on some vehicles there may already be an access hole to utilize. If not, choose a location that is easy to reach and will not obstruct or contact anything else. Check to make sure it is a clear path for the drill to go through and create the hole.
- k) The harness will split off in 2 different directions. Route the end with the 4 wires with male terminals on the end into the cab via the 1" hole. Be careful of the sharp edges of the hole that they do not slice any of the wires as they are being passed through.
- l) Locate a spot inside the cab to mount the Variable Speed Controller. It should be mounted where it is both visible and within easy reach of the operator.
- m) Connect the wires to the corresponding ends on the controller (see wiring diagram).
- n) Route the other half of the harness to the battery and connect the red to positive and black to ground on the battery. Connect the plugs at the back of the truck to the Salter and test the unit.
- o) Using accessible options (frame holes, brackets) securely fasten the harness with zip ties making certain to avoid sharp, moving, or hot objects. It is best practice to avoid zip tying harnesses to fuel or brake lines. Note: If there is remaining slack wire in the harness, try to divide it evenly between front and back should a repair be required in the future.
- p) Make certain that the wires going into the cab are secured in a manner that will not interfere with or limit the driver's feet or range of movement.
- q) Continue zip tying all the way to the back of the truck. Try to keep the wires as straight and neatly arranged as possible. Use loom or silicone in areas that are rough or require extra protection.
- r) Seal the 1" diameter access hole in the firewall with silicone making sure that the wires are not rubbing against the edges of the hole.
- s) Apply dielectric grease to all the electrical connections and plugs. This should also be done on a regular basis to prolong use and prevent corrosion.

t) Attach licence plate light with supplied 48” wire to tailgate plug (not supplied).

Operating the Salter

Before using Salter, read and familiarize yourself with all functions of this Salter.

-The Salter works best if bagged rock salt is used. Rock salt is a coarse material that will flow better due to its size and lower moisture content.

It is strongly recommended to load spreader at the job site and to do dispense all of the materials at the job site.

To fill your Salter, vehicle should be in park and not running. Undo lid clamps and remove lid from Salter (also not running). Fill Salter only to the required level. Do not exceed Hitch Mount Capacity on truck Hitch Mount. Do not exceed weight capacity of hitch mount Salter. It is strongly recommended to load spreader at the job site and to do dispense all of the materials at the job site.

- With the vehicle running, start the unit by flipping the On/Off switch to “On”. There will be a momentary surge at full power and then it will settle back to the motor speed indicated on the knob. The flow and spread can be monitored and adjusted while in operation.
- To increase volume, drive slower
- For a wider spread, increase the speed of the spinner
- Do not exceed 20 km/h while spreading
- Use caution while spreading in populated areas; monitor spread to ensure overspray does not contact vegetation
- Turn unit off by flipping On/Off Switch to the “Off” position and go to next jobsite.
- Once the shift is done, empty out any unused Salt
- To remove unit from vehicle it must be empty. Undo ratchet straps. Unplug the unit, apply dielectric grease to both ends of the plug and install dummy plug to protect from elements.
- Undo safety clip and remove hitch pin from receiver.
- With the help of an assistant, grab the unit firmly with both hands and pull away from truck. When the hitch is almost out of the receiver, start to pivot the unit down towards the ground until the wheels contact. Once the weight of the Sander is transferred to the wheels, it can easily be transported to a secure area for storage.

Transporting Vehicle when the Salter is attached

- Do not exceed 70 km/h when driving with empty spreader.
- Do not transport with the Salter filled up with salt. The weight of a filled Salter will increase braking distance and will impair vehicle handling. Transporting with the Salter filled with salt will tend to pack material and cause problems when beginning to spread material.

- Inspect Salter attaching hardware for wear or damage and be sure that Salter is properly secure before transporting. Ensure safety clip is on hitch pin and check that ratchet straps are secure.

Storage / Maintenance

When unit is stored between storms, or put away for the off-season months, use the following guidelines to help extend the life of the Salter:

- a) When unit is removed from the vehicle, it should be thoroughly cleaned and lubricated. Wash hopper out, clean spinner disc and shaft. Apply a film of grease or lubricant to the shaft and disc as well as the receiver and hitch.
- b) At this time, it is wise to check all components for appreciable wear. Any components which are questionable should be replaced now. This short and simple check will avoid down time during the operating season.
- c) Store unit in a clean, dry place. It can be safely stored upside down with the lid removed and raised up off the ground (on a skid or some 2 x 4's) so moisture does not settle inside.

Salt Spreader Controller (90254-H) System Overview 2020& After

The Salt Spreader controller is an electronic module powered off the ignition circuit +12Vdc and supplying the heavy motor current from the Battery +12 Vdc. The Salt Spreader controller and Motor(s) will only function with the ignition key in the ON state. The Salt Spreader controller is connected to the Salt Spreader hopper and associated motors via a custom wire harness that is designed to handle the high motor currents. The controller is to be mounted under the vehicle dash using the U bracketry and mounting hardware that is provided in the kit. The kit includes a 6-way connector and associated wire harness.

Once the Spreader switch located on the controller front cover is turned to the ON position, the Salt Spreader Motor will automatically be activated with 5 Blasts. The intent of this automatic operation is to check the Spreader Motor and confirm that it is functioning properly. At this time the Spreader and Vibrator operations are ready for employment.

The Spreader and Vibrator functions are controlled by selecting and activating the corresponding switch.

Salt spreader controller operation

The Salt Spreader controller will provide the Spreader Motor with variable speed rotation and Vibration Motor as follows:

- | | |
|------------------------------|--|
| Spreader Motor I (ON) | Depress Spreader rocker switch to the I (ON upper) position. |
| Spreader Motor O (OFF) | Depress Spreader rocker switch to the O (OFF center) position. |
| Spreader Motor II (AUTO) | Depress Spreader rocker switch to the II (AUTO lower) position. The spreader motor will automatically stop when the operator has depressed the vehicle brake pedal for 5 seconds. The spreader will automatically start when the operator has released the vehicle brake pedal. |
| Spreader Motor Speed Adjust. | Rotate the Spreader speed dial clockwise to increase speed and rotate the dial counter clockwise to reduce the speed. The illuminated faceplate has a graduated indicator. When the speed dial is at fully counter clockwise position, the spreader will not rotate. When the speed dial is at the fully clock wise position, the spreader will rotate at its fastest speed. |

Spreader Motor I (BLAST)	Depress Blast rocker switch to the I (ON upper) position. Motor will rotate at the fastest speed. The Blast switch I position is momentary and will return to the O (OFF) Position as soon as the operator releases it. The blast function is enabled only when the spreader motor switch is on the I (ON) or II (AUTO) position.
Vibrator Motor I (ON)	Depress Vibrate rocker switch to the I (ON upper) position. The Vibrator switch I (ON upper) position is maintained and will remain in this position until the operator depresses the rocker switch to the O (OFF center) position. The vibrator function is enabled only when the spreader motor switch is on the I (ON upper) or II (AUTO lower) position.
Vibrator Motor O (OFF)	Depress Spreader rocker switch to the O (OFF center) position.
Vibrator Motor II (AUTO)	Depress Vibrator rocker switch to II (AUTO lower) position. The vibrator motor will automatically start and stop. The Vibrator switch II (AUTO lower) position is maintained and will remain in this position until the operator depresses the rocker switch to the O (OFF center) position. The vibrator motor will remain ON for 10 seconds then will turn off for 60 seconds. The vibrator will then repeat this cycle while the switch is in the II (AUTO lower) position. The vibrator function is enabled only when the spreader motor switch is on the I (ON upper) or II (AUTO lower) position.
WHITE Power Indicator	The controller face plate will illuminate WHITE once the Ignition switch has been activated and powers up the controller.
GREEN Speed Indicator	The controller face plate will gradually illuminate darker shades of GREEN as the speed dial is turned to the clockwise (faster) level and will return back to WHITE as the dial is turned counter clockwise toward the slow (OFF) speed.
AMBER Spreader II (AUTO)	The controller face plate will illuminate AMBER once the Indicator Spreader rocker switch has been selected to the II (AUTO) position.
PURPLE Vibrate indicator	The controller face plate will illuminate PURPLE once the Vibrator rocker switch has been selected to the I (ON) position.

The controller face plate will illuminate PURPLE when the Vibrator rocker switch has been selected to the II (AUTO) position. The face plate will illuminate only when the vibrator motor is being activated and is vibrating.

During the off period, the controller face plate will illuminate white.

BLUE Blast Indicator

The controller face plate will illuminate BLUE once the Blast rocker switch has been selected to the I (ON) position.

RED Fault Indicator

The controller face plate will illuminate RED if a fault condition occurs with the spreader motor.

Safety features

- Spreader Motor over current shutdown. In the event that the spreader motor consumes more than 40 Amps of current, the controller will detect and shutdown the spreader motor. The controller face plate will illuminate, and flash RED. Resetting is accomplished by turning the Spreader rocker switch to the O (OFF) position then back to the I (ON) or II (AUTO) position. If the condition has not been cleared the process will repeat itself.
- There are two fuses located at the rear of the controller housing. These are automotive ATO fuses. A 10A fuse protects the Vibrator motor. A 30A fuse protects the Spreader motor. In the event that the fuse has opened circuited, replacement of the fuse will be required in order to restore the operation. Fuse replacement is facilitated with a pair of needle nosed pliers.

Convenience features

- Upon depressing the Spreader Motor rocker switch to the I (ON) or II (AUTO) position, the Spreader Motor will be energized to rotate for 5 quick short blasts. The intention of this feature is to check the circuitry of the motor and confirm that it is electrically ready to operate. Furthermore the 5 short blasts are intended to clean and prepare the salt path way of the hopper.
- Upon depressing and selecting the Spreader Motor rocker switch to the II(AUTO) position, the Spreader Motor will automatically commence to rotate at the speed selected by the speed dial and while the operator does not have their foot applied to the vehicle brake pedal. Upon continuous depression of the vehicle brake pedal in excess of 5 seconds, the Spreader motor will be disabled stopping rotation

and salt spreading. Upon continuous release of the brake pedal for more than 5 seconds, the Spreader motor will once again be enabled commencing rotation and the spreading of salt. The process will repeat itself until the rocker switch has been depressed to the O (OFF) position or the I (ON) position which over rides the brake disable feature.

- Upon depressing and selecting the Vibrator Motor rocker switch to the II (AUTO) position, the Vibrator Motor will automatically commence to vibrate the hopper for 10 seconds then turn off for 60 seconds then repeat the cycle until the switch has been returned to the O (OFF) position.

Fault Diagnostic RED face plate

- The controller faceplate will illuminate RED.

Face plate background colours

WHITE: Controller Power ON.

AMBER: Spreader Power II (AUTO).

GREEN: Spreader Power I (ON) Variation in speed. Green = MAX speed.

Lighter shades of green relate to the slower speed dial setting.

White = O off. Amber = O in II (AUTO). PURPLE:

Vibrator Motor Power I (ON).

BLUE: Spreader Motor Blast Power I (ON).

RED: Fault diagnostic.

Connection

The picture below shows the connection of the power in and out for the motor. Red wire is for the power in from battery and white wire is power out to the motor.

Both wires will use ¼ inch female disconnect on both ends.



HM Salter controller (90254-H) wire functions

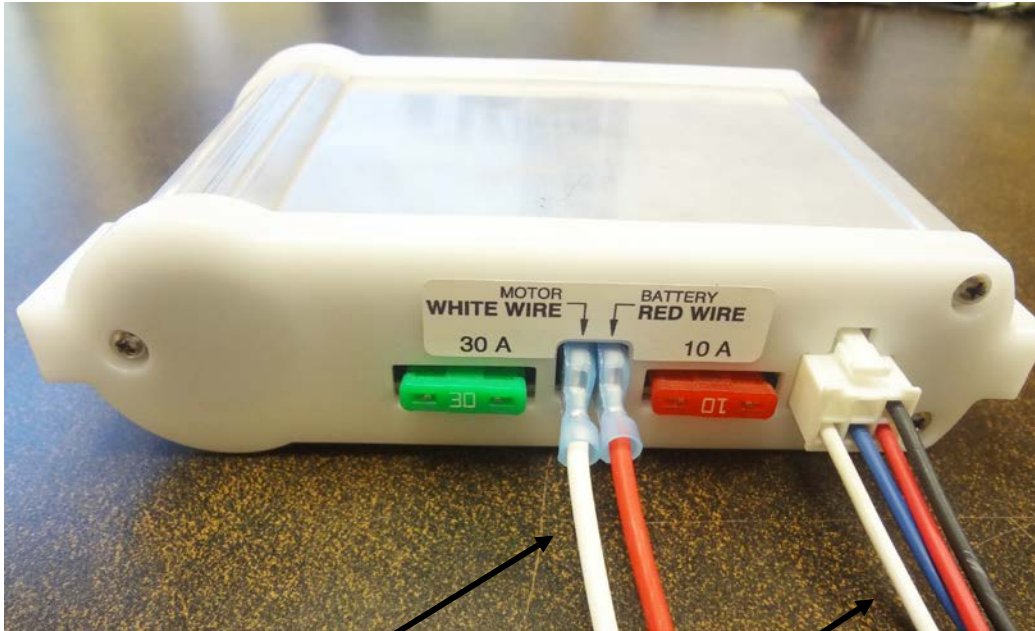

Two wires coming out individually

- Red goes to Red wire on harness
- White goes to white wire on harness

Four Wires coming out of the white plug

- Red goes to vehicle Ignition
- Black goes to vehicle's battery ground (-)
- White goes to vibrator (if equipped)
- Blue goes to the vehicle's brake light

- 10 Amp fuse to protect vibrator motor
- 30 Amp fuse to protect salter motor

2020 & After

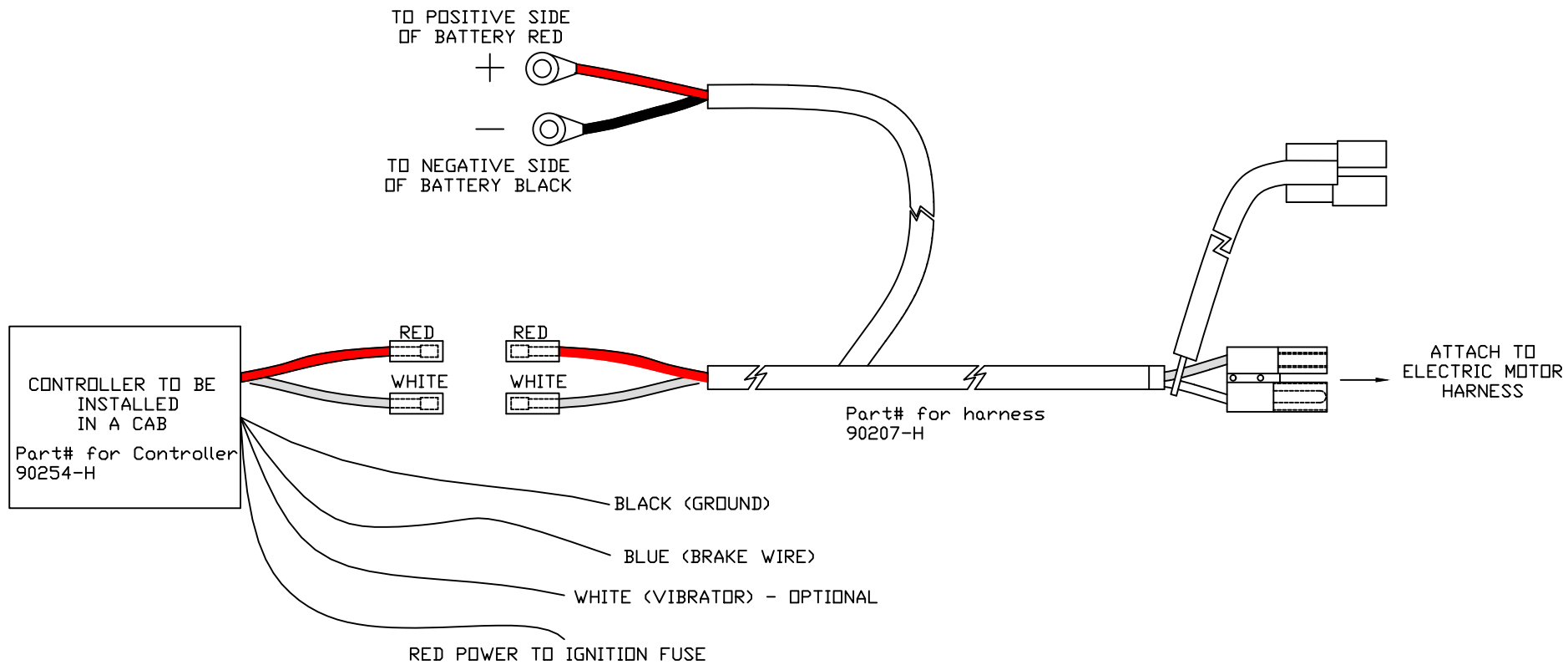

Prior 2020

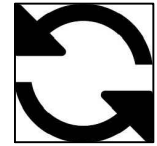

Part# for Controller
90254-N

A spinner should always rotate in counterclockwise direction.

If a spinner rotates in clockwise direction, switch the position of white and brown wire on the controller.

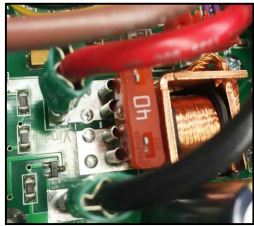

40 Amps fuse inside the controller

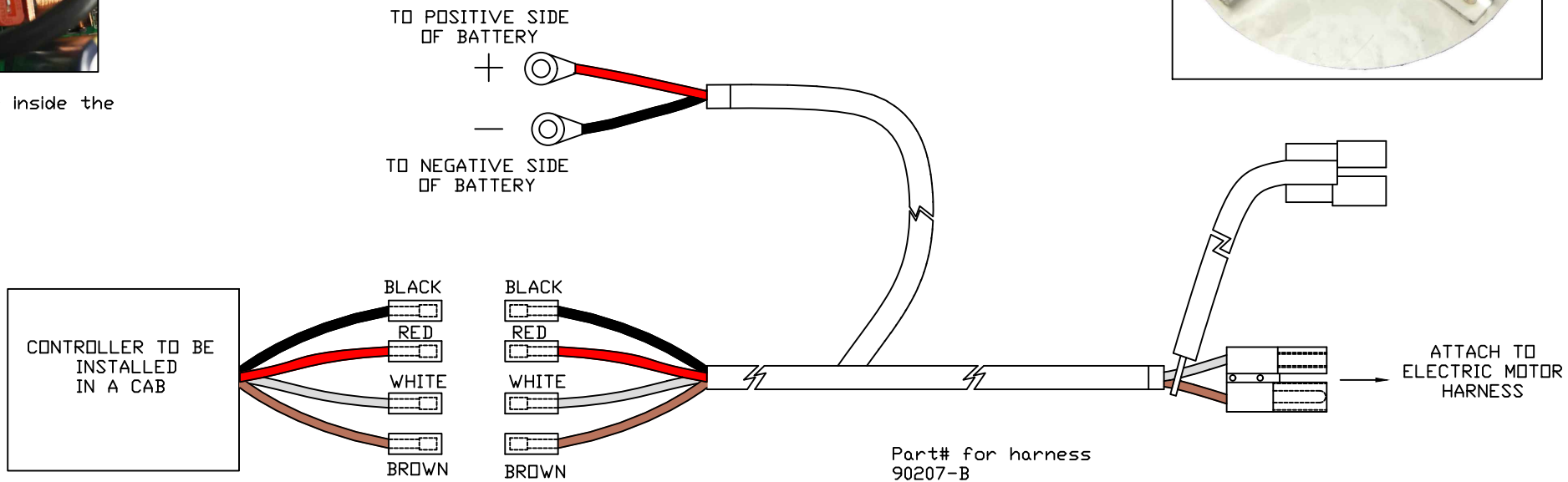

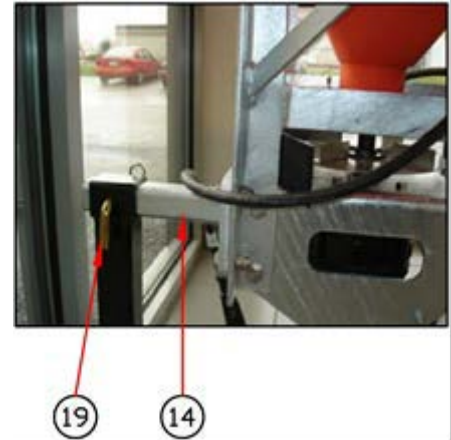
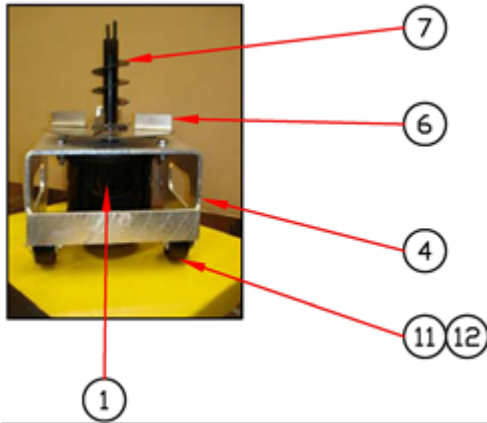

SERIAL # STICKER

Hitch Mount poly salter 8 cu.ft (HM8P)			
	Part #	Description	Quantity
1	90253-N	Motor	1
2	90254-N	Controller	1
3	90211-D	Frame	1
4	90230-B	Motor Plate	1
5	90224-A	Deflector	1
6	90225-B	Spinner Disc	1
7	90226-B	Auger	1
8	90240-N	U-Bolt	1
9	90209-D	6 cu ft Poly Hopper	1
10	90210-D	8 cu ft Poly Hopper	1
11	90238-N	Caster Wheel	2
12	90239-N	Axle with Grease fitting	2
13	90206-M	Lid Assembly	1
14	90221-B	Shank	1
15	90235-M	License Plate	1
16	90228-N	Ratchet Strap	2
17	90207-B	Harness	1
18	90229-N	Light	1
19	51830-B	Pin	1
20	90227-N	Hold Down	1

Hitch mount poly salter 8 cu.ft. HM8P)			
	Part #	Description	Quantity
1	90253-N	Motor	1
*2	90254-N	Controller	1
3	90211-D	Frame	1
4	90230-B	Motor Plate	1
5	90224-A	Deflector	1
6	90225-B	Spinner Disc	1
7	90226-B	Auger	1
8	90240-N	U-Bolt	1
9	90209-D	6 cu ft Poly Hopper	1
10	90210-D	8 cu ft Poly Hopper	1
11	90238-N	Caster Wheel	2
12	90239-N	Axle with Grease fitting	2
13	90206-M	Lid Assembly	1
14	90221-B	Shank	1
15	90235-M	License Plate	1
*16	90228-N	Ratchet Strap	2
*17	90207-B	Harness	1
*18	90229-N	Light	1
19	51830-B	Pin	1
20	90227-N	Hold Down	1
21	90242-N	5/16 x 1/4 Set Screw	1
22	HH-00300-051	3/8 x 1 1/2 Hex Head Screw Stainless Steel	4
23	HH-00271-006	3/8 Flat Washer Stainless Steel	4
24	HH-00086-001	3/8 Nut with Nylon Insert Stainless Steel	4
25	HH-00300-064	1/2 x 1 1/2 Hex Head Bolt Stainless Steel	8
26	HH-00086-003	1/2 Nut with nylon Insert Stainless Steel	8
27	HH-00300-003	1/4 x 3/4 Hex Head Bolt Stainless Steel	5
28	HH-00086-016	1/4 Nut with Nylon Insert Stainless Steel	5
29	HH-00017-104	3/4 Cup Screw	1
30	HH-00300-027	5/16 x 1 Hex Head Bolt Stainless Steel	4
31	HH-00086-017	5/16 Nut with Nylon Insert Stainless Steel	4
32	53207-N	Nut, License Plate	2

*Items are not shown on the drawing.

Three point Hitch 90258-M

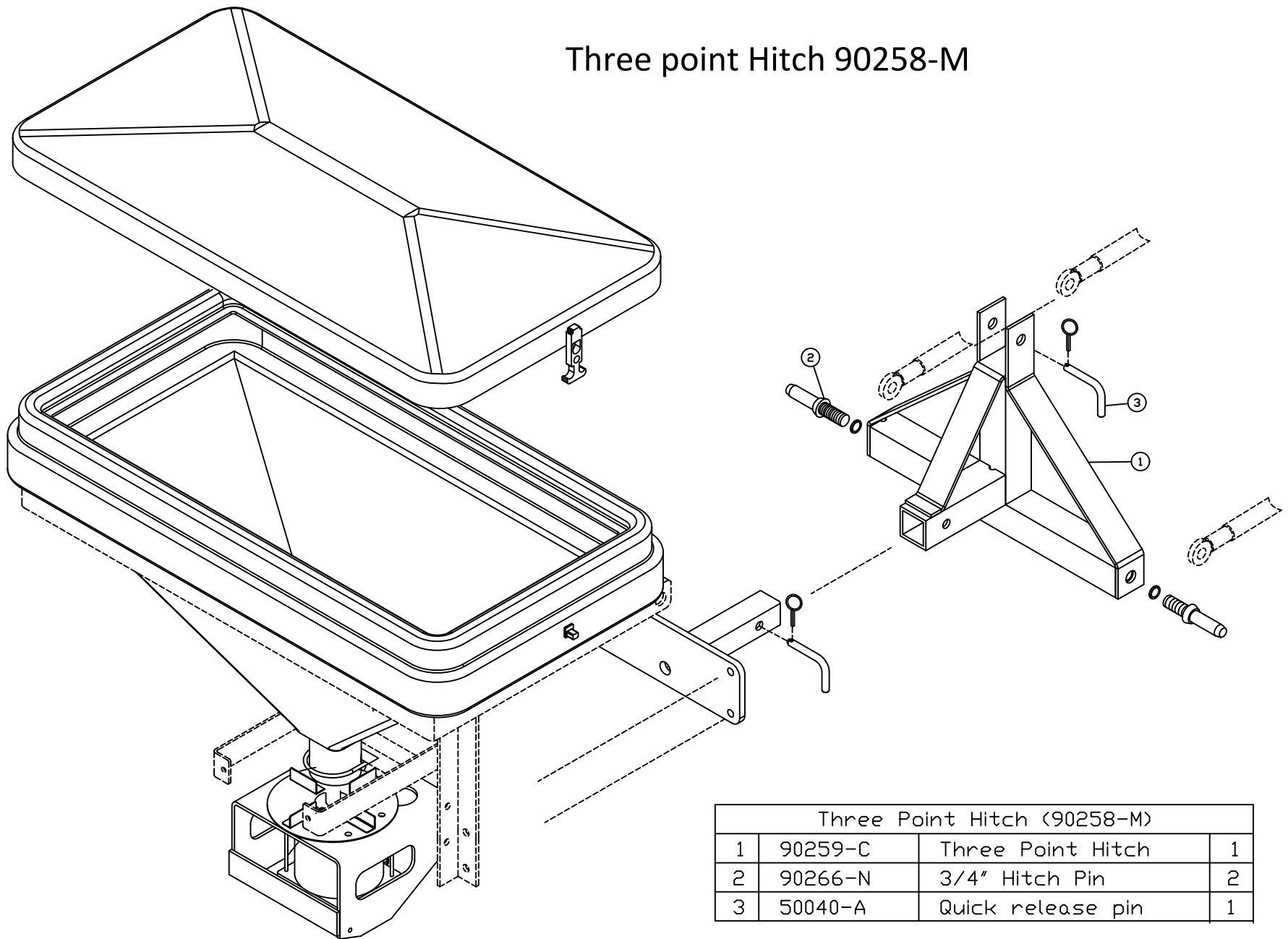

Three Point Hitch (90258-M)			
1	90259-C	Three Point Hitch	1
2	90266-N	3/4" Hitch Pin	2
3	50040-A	Quick release pin	1

Hitch Mount Swing Arm 90270-M

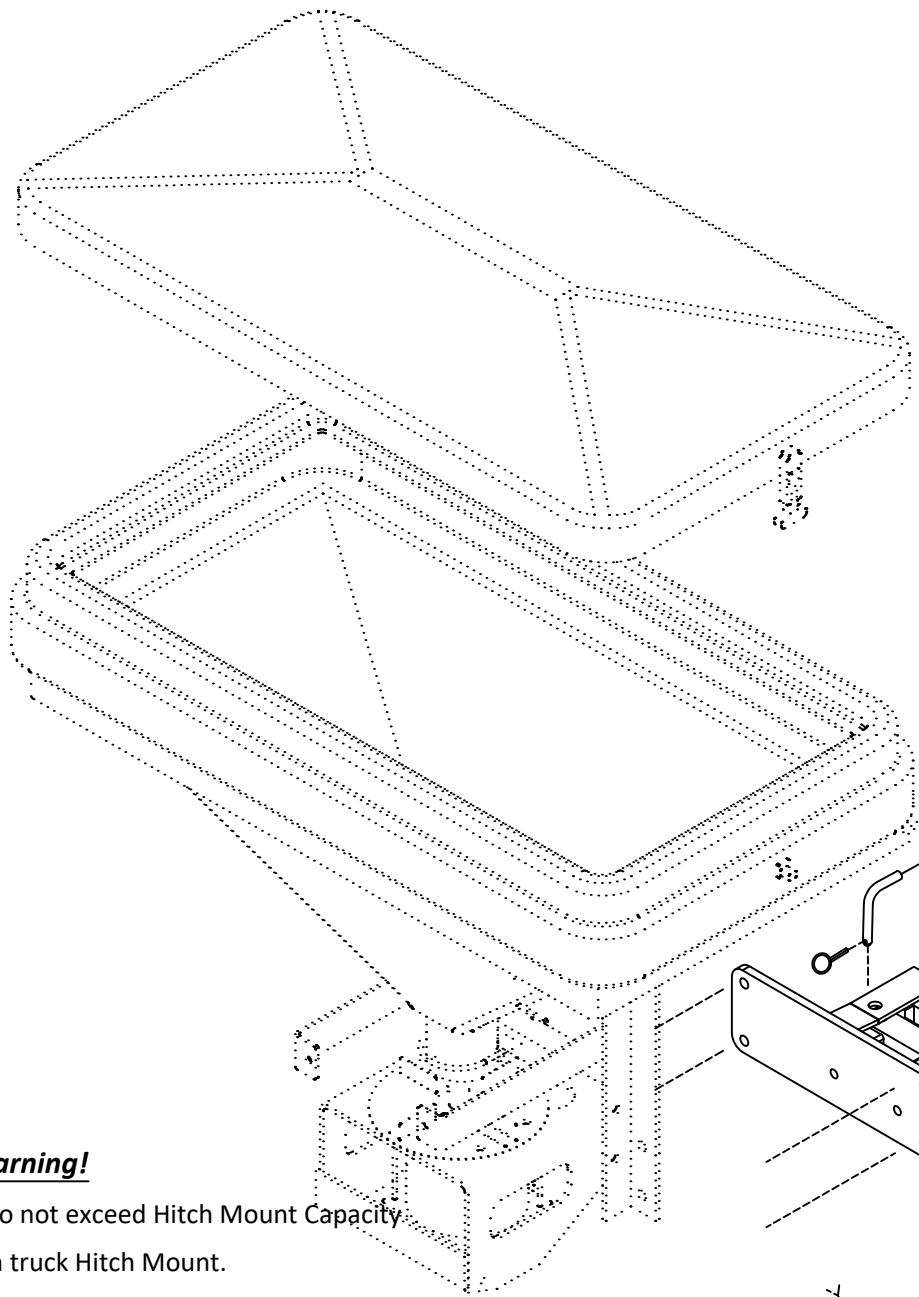

Installation

- Assemble a spreader swing arm (2) to a spreader hitch arm (1) with a bolt and a nut (3)(4) and tighten bolt parts (apply grease into the pivot joint to prevent corrosion).
- Collapse assembly and install a hitch pin (5) with a clip to keep assembly from opening.
- Install Hitch Mount Salter to the mount spreader arm and secure using four ½" bolts and nuts.
- Insert Hitch Mount Salter into a vehicle receiver hitch, and insert a hitch pin and secure it with a clip.
- Install ratchet straps and secure Hitch Mount Salter.

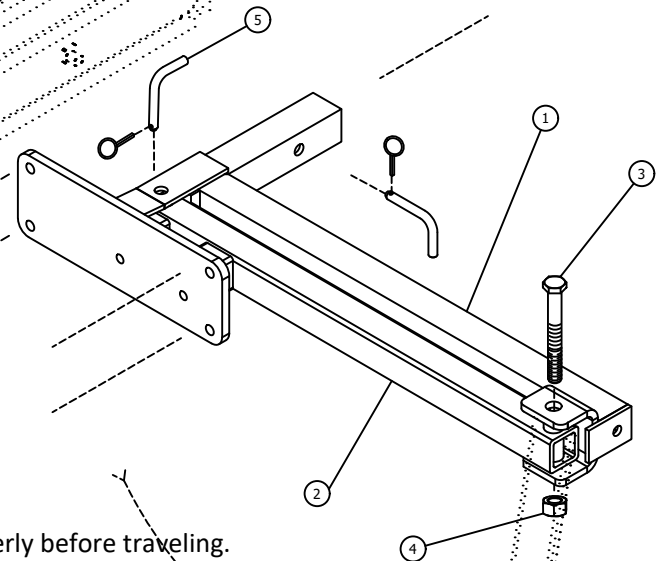

Warning!

- Do not exceed Hitch Mount Capacity on truck Hitch Mount.
- Swing Arm can be used only if a spreader is empty.
- All pins and ratchet straps **must be attached** and secured properly before traveling.
- A spreader must be loaded at the job site and dispense all of the materials at the job site.

Hitch Mount Swing Away 90270-M			
	Part #	Description	Quantity
1	90271-D	Spreader Hitch arm	1
2	90272-D	Spreader Swing Arm	1
3	HH-00972-156	¾ x 4 ½" Bolt	1
4	HH-00973-007	¾" Nut	1
5	51830-B	Hitch Pin	1

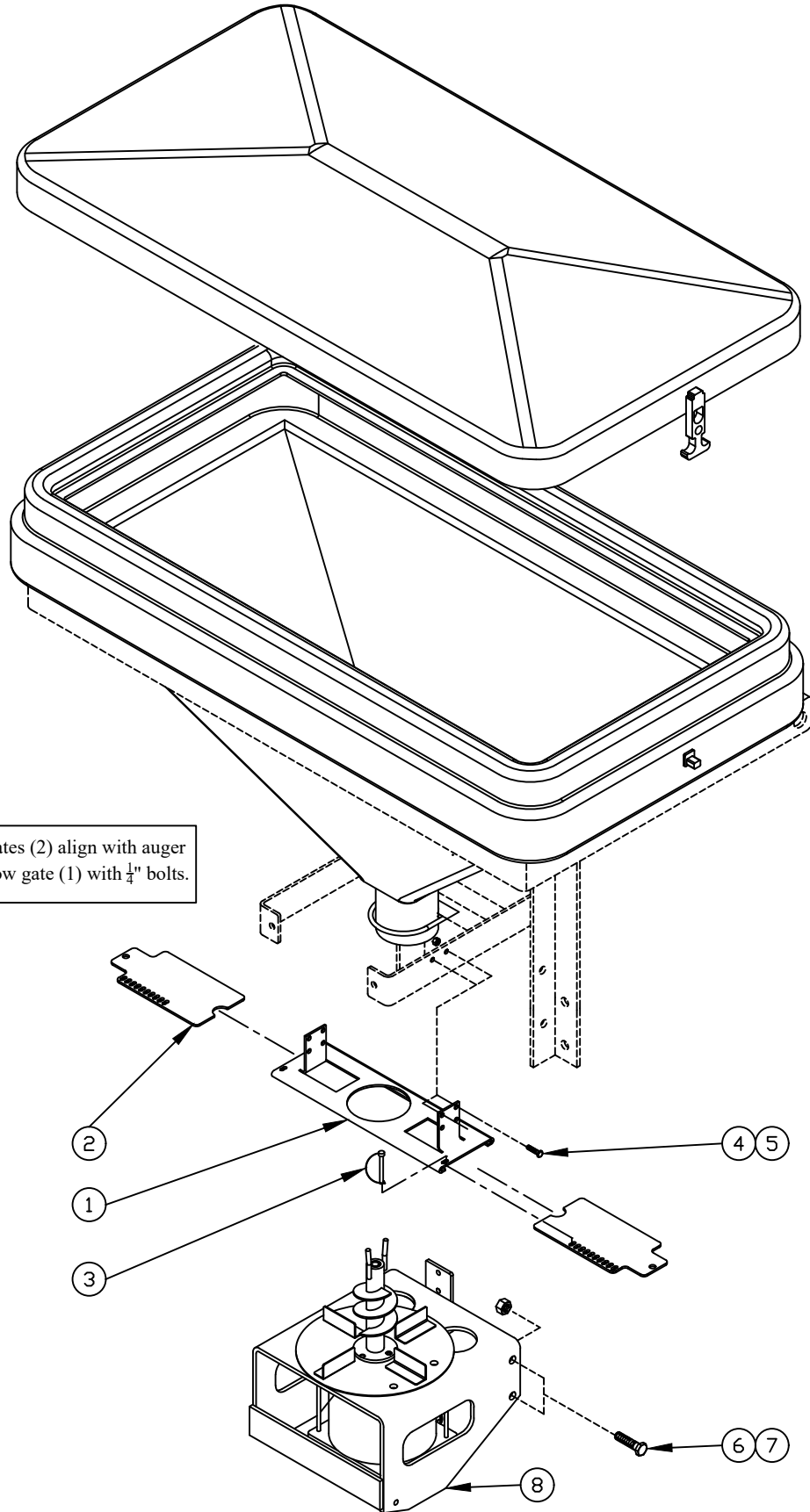

Assure that flow gate plates (2) align with auger shaft, before securing flow gate (1) with $\frac{1}{4}$ " bolts.

2

1

3

4 5

6 7

8

Flow Gate Kit 90267-M			
	Part #	Description	Quantity
1	90268-B	Flow Gate	1
2	90269-A	Flow Gate Plate	2
3	53183-01-N	Snapper Pin	2
4	HH-00086-016	¼ Hex Head Bolt Stainless Steel	4
5	HH-00300-003	¼ Nut with nylon Insert Stainless Steel	4
*6	HH-00300-064	½ x 1 ½ Hex Head Bolt Stainless Steel	4
*7	HH-00086-003	½ Nut with nylon Insert Stainless Steel	4

*Items #6 and #7 are not part of the Flow Gate Kit 90267-M.

1. Disconnect power to the motor. Remove Motor Mounting Plate (8) (remove four ½” bolts and nuts (6)(7))
2. Install a flow gate (1) against the bottom of the hopper and secure it with clamps.
3. Reinstall Motor Mounting Plate (8) using four ½” bolts and nuts (6)(7) (assuring that an auger is in centered inside of the hopper).
4. Insert Flow Gate Plates (2) in Flow Gate (1). (Note: Assure that Flow Gate Plates (2) align with an auger shaft).
5. Secure Flow Gate (1) using it by four ¼” bolts and nuts (4)(5).
6. Adjust Flow Gate Plates (2) on desired opening and secure it with Snapper Pin (3).

Salter Screen mounting kit 90298-M



Picture #1

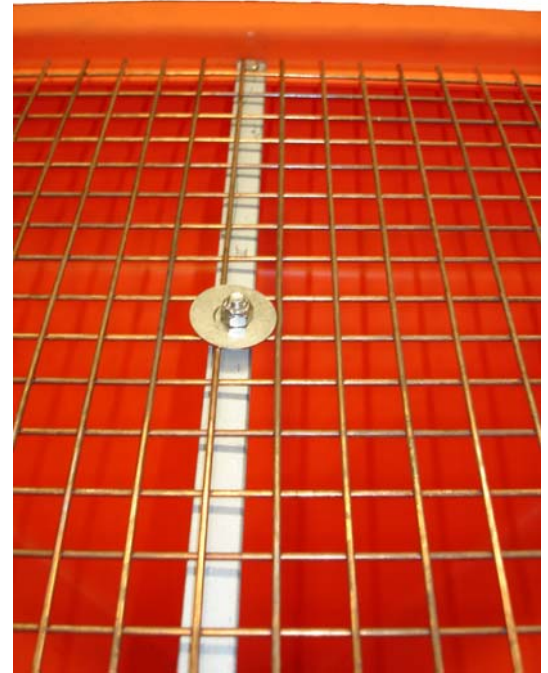

Picture #2

1. Place a screen on the top of a hopper. Find (mark) the center of a hopper, where a cross member bracket will be installed.
2. Remove a screen and install mounting bracket as shown on the picture #1. (Drill 2 x 1/4" holes in the hopper and secure it using 2 x 1/4" bolts, flat washer and nuts). Install 5/16" bolt and nut in the middle of the bracket.
3. Install a screen and secure it using 1.5" OD flat washer and 5/16" nut—picture #2.

90298-M HMP Screen Kit			
	ITEM	DESCRIPTION	QUANTITY
1	90300-B	Cross Member	1
2	90299-M	Screen	1
3	90293-N	Flat washer 1.5" dia	1
4	HH-00086-017	5/16 Nut	2
5	HH-00300-027	5/16 Bolt	1
6	HH-00300-003	1/4 Bolt	2
7	HH-00086-016	1/4-20 Nut	2
8	HH-00271-005	Flat washer	2

Inverted V – Galvanized (90142-M)

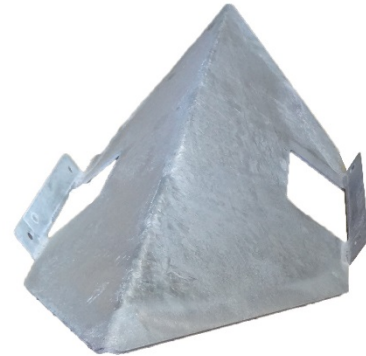

Side view of Inverted V



Top view of Inverted V

Work light (LED) kit for Sander

Part# 90315-M

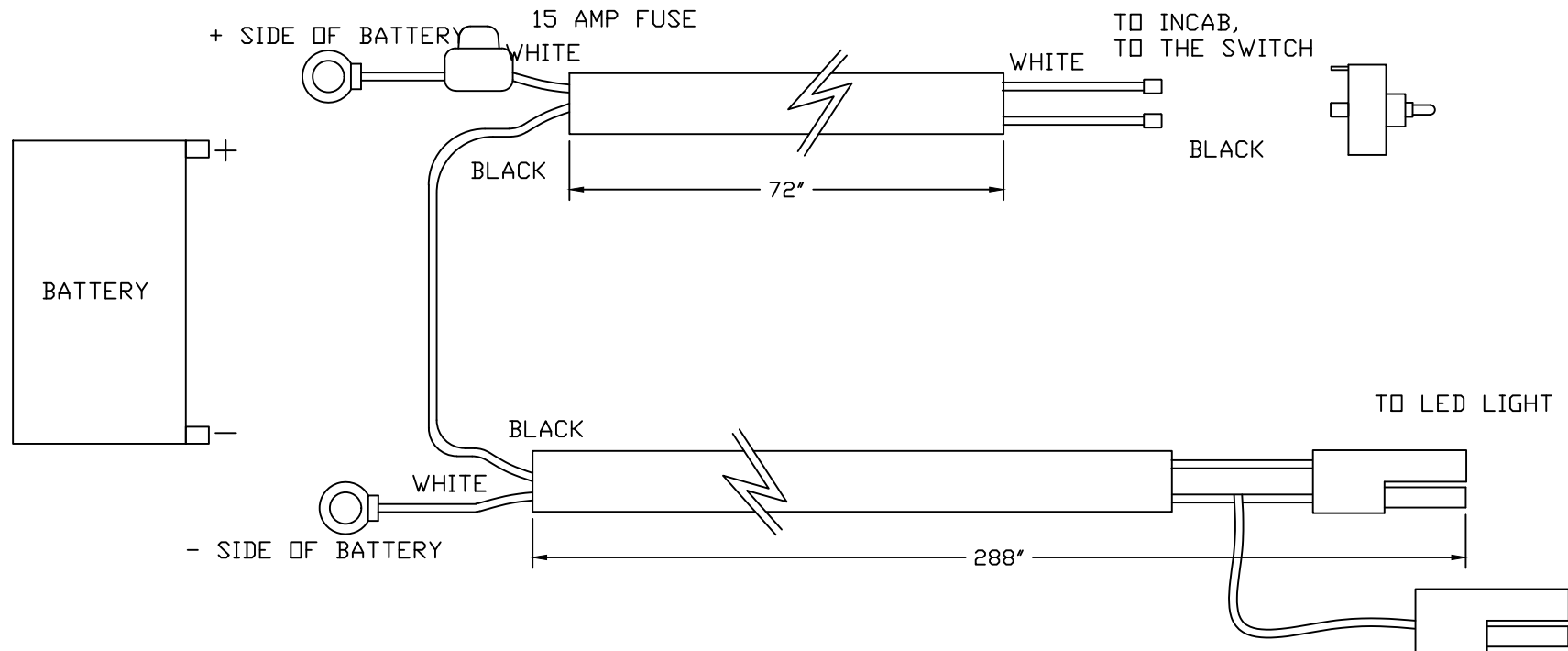

Work light kit 90315-M			
	Part#	Description	Quantity
1	90311-M	4 1/2" Round LED Work light, 1800 lumens	1
2	90004-M	On/Off switch	1
3	52018-M	Light Switch bracket	1
4	90292-B	Harness	1



Installation Instructions for work light kit:

1. Attach the battery connections from wire to the battery.
2. Mount switch inside the cab using switch bracket provided in the kit.
3. Run wires from harness inside the cab, connect them to the switch.
4. Mount the LED light in appropriate location shown above by drilling 5/16" holes, light can be mounted on either side of sander based on length of the harness.
4. Run the harness all the way to back of sander, plug the two-way trailer plug connectors to the LED light.

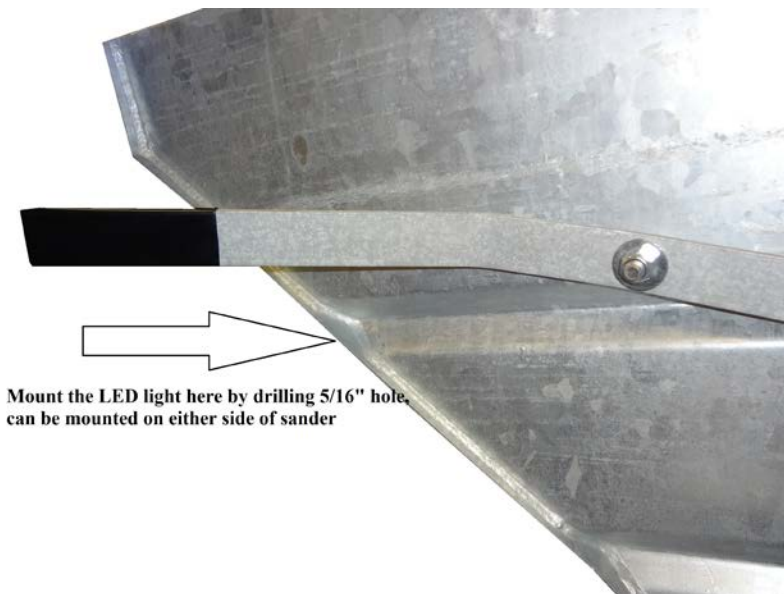

Arctic Equipment Manufacturing Corporation reserves the right under its product improvement policy to change construction or design details and furnish equipment when so altered without reference to illustrations or specifications used.

Vibrator Kit

Part # 90290-80-H

2020 & After

2020 & After

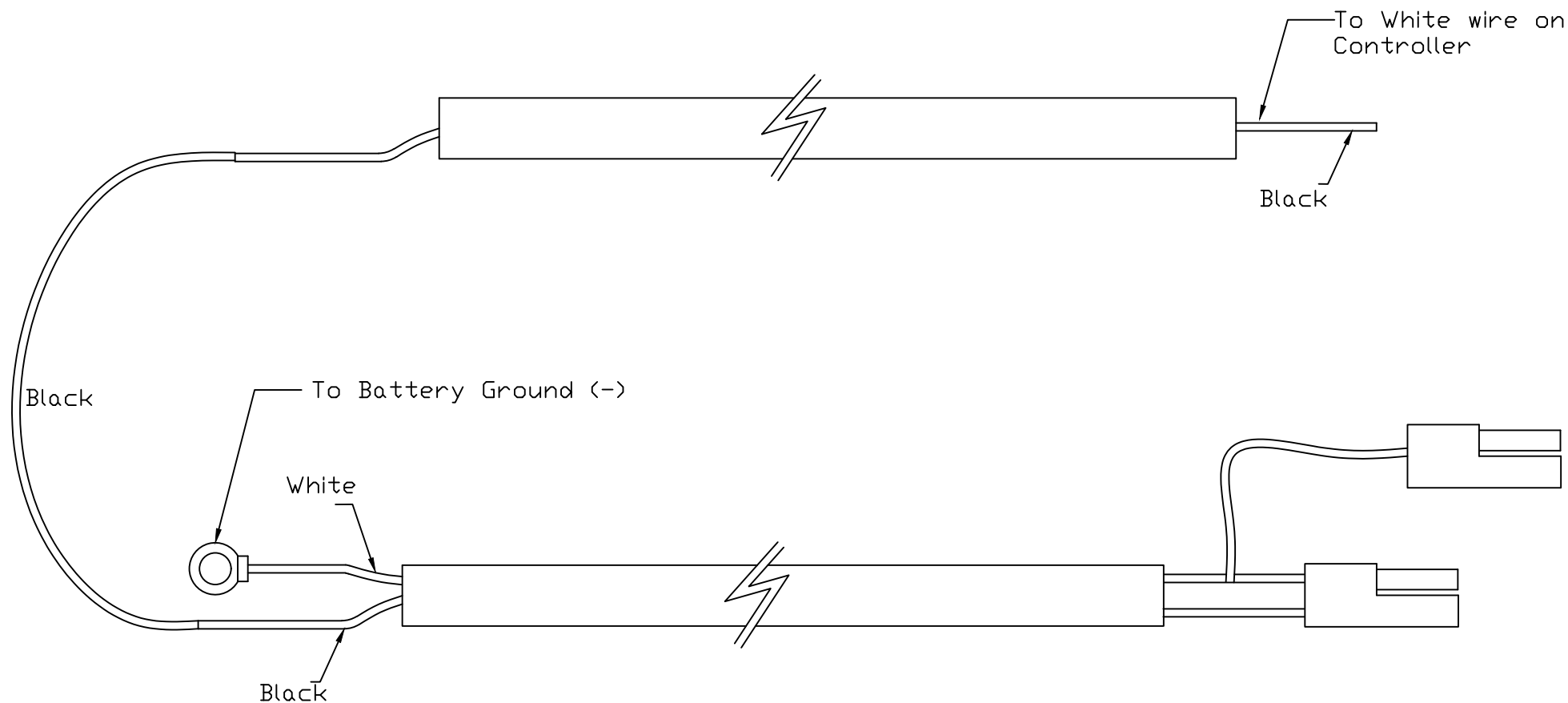

Note: Vibrator harness to be used with 90254-H Controller

Vibrator kit for a hitch mount poly salter 90290-80-H (2020 & After)			
	Part #	Description	Quantity
1	90290-80-N	Vibrator	1
2	90292-H	Harness	1
3	90257-A	Support Plate	1
4	HH-00300-051	3/8" x 1 1/2 Hex Head Screw Stainless Steel	4
5	90293-N	3/8" Flat Washer Stainless Steel	4
6	HH-00086-001	3/8" Nut with Nylon Insert Stainless Steel	4

Installation Instructions for hitch mount poly salter:

1. Locate the vibrator (1) as shown on the picture below, approximately 7" (+/- 1") from the line off the throat entry.
2. Mark the mounting holes on the hopper and drill 7/16" holes through.
3. Install the support plate (3) from the inside of hopper and secure it using 3/8 bolt, flat washer, and nut (4)(5)(6).
4. Disconnect vehicle electrical system from the battery. Install the harness as shown on the attached diagram.

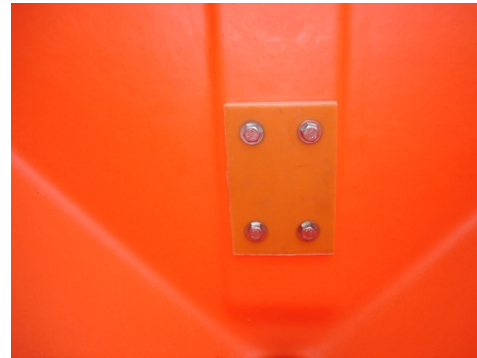

Warning: Vibration is a destructive force and it may damage sander and hopper body. You may use this vibrator at your own risk. In no event shall Arctic Equipment Manufacturing Corporation be liable for claims for loss of use or consequential damages.

Arctic Equipment Manufacturing Corporation reserves the right under its product improvement policy to change construction or design details and furnish equipment when so altered without reference to illustrations or specifications used.

Vibrator Kit

Part # 90290-80-M & 90291-200-M

Prior 2020

Prior 2020

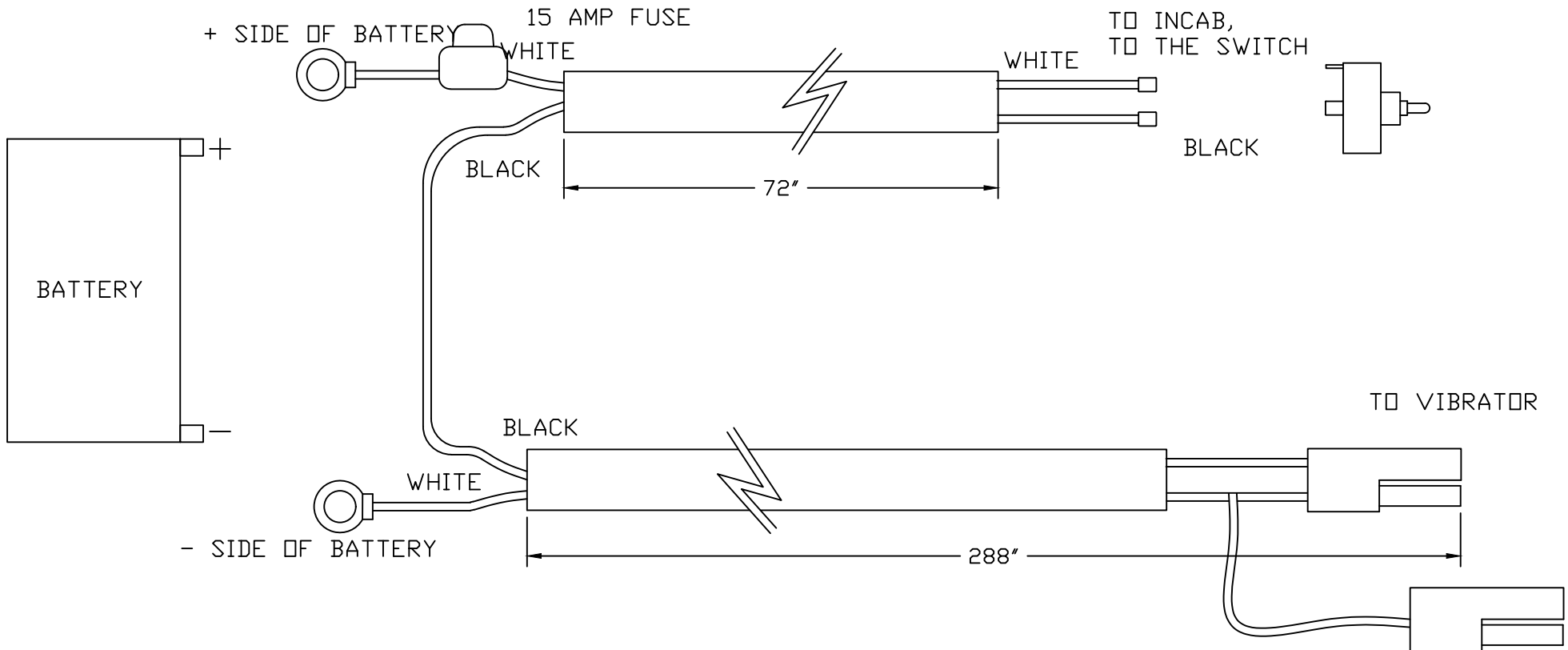

Note: Vibrator harness to be used with 90254-N Controller

Vibrator kit for a hitch mount poly salter 90290-80-M			
	<i>Part #</i>	<i>Description</i>	<i>Quantity</i>
1	90290-80-N	Vibrator	1
2	90292-B	Harness	1
3	90310-N	On/Off Switch	1
4	90257-A	Support Plate	1
5	HH-00300-051	3/8" x 1 1/2 Hex Head Screw Stainless Steel	4
6	90293-N	3/8" Flat Washer Stainless Steel	4
7	HH-00086-001	3/8" Nut with Nylon Insert Stainless Steel	4
8	52018-M	Bracket	1

Installation Instructions for hitch mount poly salter:

1. Locate the vibrator (1) as shown on the picture below, approximately 7" (+/- 1") from the line off the throat entry.
2. Mark the mounting holes on the hopper and drill 7/16" holes through.
3. Install the support plate (4) from the inside of hopper and secure it using 3/8bolt, flat washer and nut (5)(6)(7).
4. Disconnect vehicle electrical system from the battery. Install the harness, the switch (switch mounting bracket) as shown on the attached diagram.



Vibrator kit for a galvanized and a poly sander 90291-200-M			
	Part #	Description	Quantity
1	90291-200-N	Vibrator	1
2	90292-B	Harness	1
3	90310-N	On/Off Switch	1
4	90257-A	Support Plate	1
5	HH-00300-051	3/8" x 1 1/2 Hex Head Screw Stainless Steel	4
6	90293-N	3/8" Flat Washer Stainless Steel	4
7	HH-00086-001	3/8" Nut with Nylon Insert Stainless Steel	4
8	52018-M	Bracket	1

Installation Instructions for the galvanized and the poly sander:

1. Locate the vibrator (1) as shown on the picture below.
2. Mark the mounting holes on the hopper and drill 7/16" holes through.
3. Install the support plate (4) from the inside of poly hopper (it is not necessary to install that plate for the galvanized sander) and secure it using 3/8bolt, 3/8 flat washer and 3/8 nut (5)(6)(7).

Disconnect vehicle electrical system from the battery. Install the harness, the switch (switch mounting bracket) as shown on the attached diagram.



Warning: Vibration is a destructive force and it may damage sander and hopper body. You may use this vibrator at your own risk. In no event shall Arctic Equipment Manufacturing Corporation be liable for claims for loss of use or consequential damages.

Arctic Equipment Manufacturing Corporation reserves the right under its product improvement policy to change construction or design details and furnish equipment when so altered without reference to illustrations or specifications used.