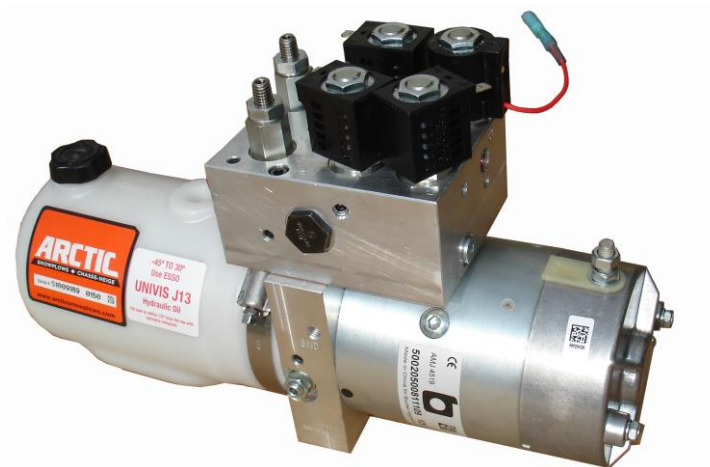

Table of Contents

Operating information.....	2
Hydraulic Operational Diagrams.....	7
Hydraulic Installations.....	11
53419-M Hydraulic Installation	16
Parts List (2011-2012).....	22
Parts List after 2012.....	25
Controller for Straight Blade.....	29
Troubleshooting flow chart.....	30

M3493 Operating Information



General Information about Power Unit M3493

General Information about Power Unit M3493

Warranty Identification

For purposes of warranty consideration, recording the serial number of the power unit is necessary. This serial number is displayed on the reservoir of the power unit.

Maintenance

Under normal operating conditions, the M3493 should not require servicing during the plowing season, provided post season maintenance has been carried out. It is recommended that after every season the hydraulic fluid to be changed. (For the first 3 years after purchase a preventive maintenance schedule must be performed in order to extend your warranty- please see your dealer for details) The replacement fluid is **UNIVIS J13 (HVI 13)** hydraulic fluid. Automatic transmission fluid is not recommended for this system and may lead to aeration of the oil in very cold weather conditions. Use of any fluid other than J13 will void warranty. The oil level in the reservoir is to be within ½" from the top surface (when lift cylinder is collapsed).

When draining the hydraulic fluid, the hoses at the cylinders should be disconnected and drained. With the hose disconnected, the cylinders should be collapsed to displace the oil out of the cylinder.

Periodically, and during post season maintenance, make sure the electrical connections are tight and free of corrosion. The terminals must be covered with grease for additional protection from corrosion.

Sometimes, in order to **release pressure in angling cylinders** it is necessary to follow these instructions: when blade is angled to the right (curb side), angle blade to the left (driver side) and as blade is angling press release button, than let go of both.

Electrical System

Frequently problems develop due to an undersized electrical charging and storage system. Generally, the heavier the usage, the heavier the system should be. For a moderately light duty, the battery should not be less than 70 ampere-hours and the alternator should charge at a rate of not less than 60 amperes. For heavy usage and in the case where a number of other devices are run off the battery simultaneously, heavier ratings are strongly recommended.

Electric Motor

The 8111 electric motor is two pole electromagnetic motor, consisting primarily of an armature/commutator, two field coils, four brushes in a brush holder set, and a tubular steel body with cast endcap.

The power unit with this motor is equipped with the 03 pump. This combination of pump and motor offers optimum performance.

Hydraulic Pump

The hydraulic pump converts mechanical energy transmitted by the prime mover (in this case a 12 volt DC electric motor) into hydraulic energy. The hydraulic energy is due to flow (kinetic energy) and pressure (potential energy). The rate of energy output is expressed in horsepower.

At the inlet, as the gears unmesh, the volume in the cavity increases thereby causing fluid to enter. This fluid is then carried between the gears and the housing to the other side of the gears into the outlet cavity. At this point the gear teeth mesh. The outlet cavity volume decreases, causing fluid to flow into the system. Note that without a load, the pressure at the outlet port is nil.

The pressure at the outlet of the pump is due to external loads placed on the system. These loads can be transmitted through cylinders and linear actuators as well as hydraulic motors and rotary actuators. In practice, system components by virtue of orifice and line sizes, offer some resistance to the flow of fluid. This translates into pressure at the outlet of the pump.

Valve Information

Pressure Relief Valve

The pressure relief valve consists of a ball, a retaining spring and a seat. The ball is exposed to the pressure in the outlet line from the pump. This pressure acting on the exposed area of the ball causes a force on the retaining spring. When the pressure is such that the force on the ball exceeds the force in the spring (due to a preset amount of precompression) the ball lifts off the seat and the fluid from the outlet of the pump is allowed to flow back to the reservoir. The "standard relief valve setting" for the M3493 is 2000 psi.

Directional Valves

The M3493 circuit contains 4 directional valves identified as 'A', 'B', 'C' and 'D'. Valves 'A', 'C' and 'D' are 3 way, 2 position spool valves. Valve 'B' is a 2 way 2 position normally closed poppet valve.

A basic directional valve consists of a valve cartridge and a coil. Inside the cartridge valve, an armature is attached to the valve mechanism.

The coil consists of a wire wrapped around a spool. When power is applied to the coil (the coil is energized), the magnetic field created by coil pulls the armature into the coil. The armature shifts the valve mechanism into the energized position. When power is removed from the coil, a spring inside the valve cartridge pushes the armature and valve mechanism

to the de-energized position.

Directional Valve 'B'

Valve 'B' is a 2 way 2 position normally closed poppet valve which is used for lowering the plow. In the de-energized position, valve B acts as a check valve allowing pump flow to the lift cylinder but preventing return flow from the lift cylinder to the reservoir. Energizing valve B opens the valve and allows flow from the lift cylinder to the reservoir thereby lowering the plow. See figure 2. Note: the lift cylinder is connected to C3.

Directional Valves 'A', 'C' & 'D'

Directional Valves 'A', 'C' and 'D' are 3 way, 2 position spool valves. Directional Valve 'C' operates the lift cylinder on C3 port (See Figure 1). Directional Valves 'A' and 'D' operate the left and right angling cylinders. Valve 'A' operates the angling cylinder on the right side of vehicle on C2 port (See Figure 3). Valve 'D' operates the angling cylinder on the left side of vehicle on C1 port (See Figure 4).

In the de-energized position, the valves block flow from pump to the cylinder but allow return flow from the cylinder to the reservoir. In the energized position, flow from the pump to the cylinder is permitted but flow from the cylinder to the reservoir is not.

Note: When angling the plow, one cylinder is extending and the other is retracting therefore one cylinder is receiving oil from the pump and the other is returning oil to the reservoir. Valves 'A' and 'D' must work together.

Cross over relief valve

The cross over relief valves are provided to protect the valves and manifold from the pressure spikes created when the plow strikes an object. The cross over relief valves are similar in construction to a regular direct acting relief valve.

Cross over valves when activated, bleed fluid from C1 to C2 or vice versa. In this manner both the angling cylinders, the plow frame and the truck frame are offered some protection from the normal impact forces associated with plowing. Striking a fixed object while plowing at high speeds will damage the cylinders and perhaps the plow. The cross over relief valves are adjustable and are normally set at about 2500 psi.

Pilot Operated (PO) Check Valve

A dual pilot operated check valve (PO Check Valve) is provided on ports C1 and C2 to hold the plow at the desired angle. Without the PO Check valves, leakage through directional valves 'A' and 'D' would allow the plow to drift.

Without pilot pressure, a pilot operated check valve (PO check valve) allows flow in

only one direction. In the free flow direction, oil flowing through the valve lifts the poppet of the seat. In the opposite direction, returning oil pushes the poppet against the seat thereby blocking flow. When pressure is applied to the pilot piston, the poppet is lifted off the seat and flow in both directions is permitted. When angling, pilot pressure is provided for the check valve returning oil to the reservoir. For example; when valve 'D' is energized pump flows oil to C1. Oil is allowed to return oil through the check valve to the reservoir because the pressure on C1 is acting on the pilot piston of the C2 PO Check Valve.

Control Switch

The M3493 uses four different control boxes: control box with rocker switches, touchpad control box, handheld controller and joystick control box. Each control box performs same functions: up, down, angle left and angle right.

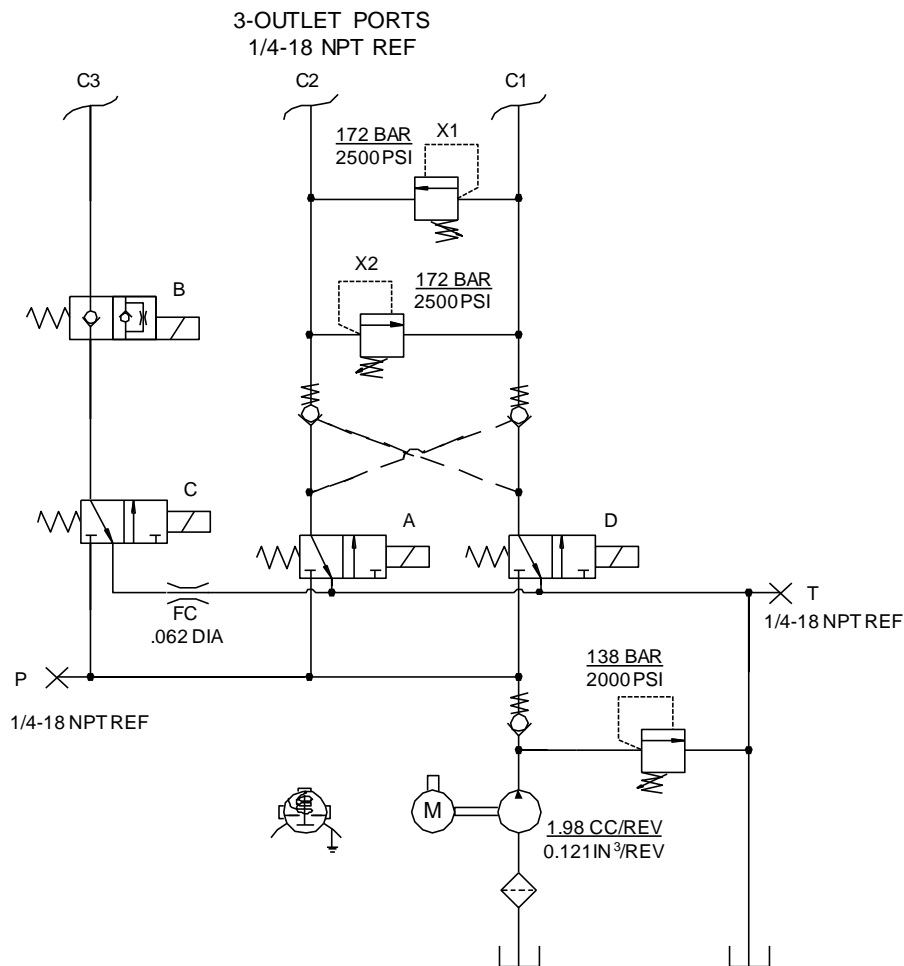

SCHEMATIC

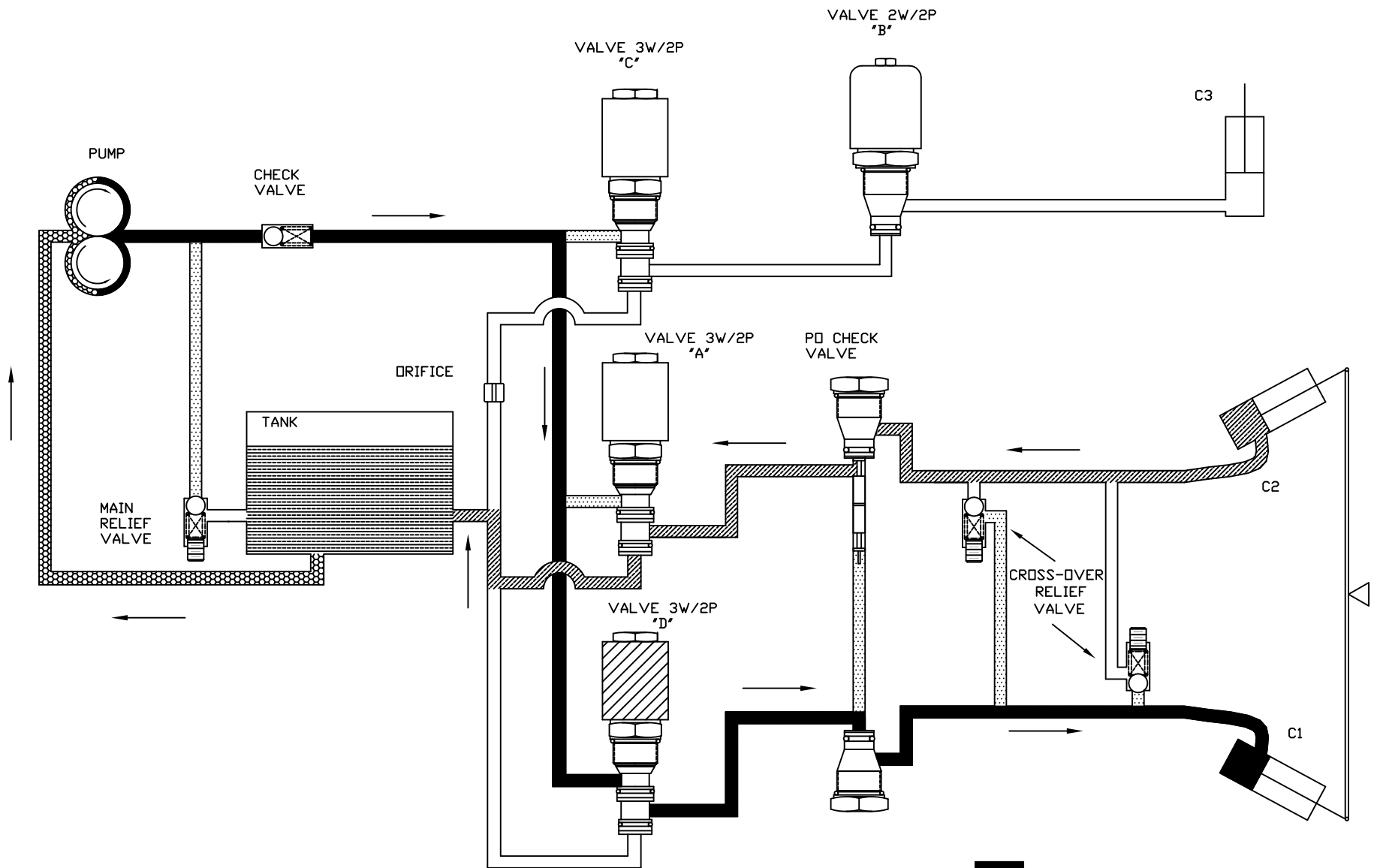

M3493
 EXTEND C1
 (ANGLE LEFT)
 FIGURE 4

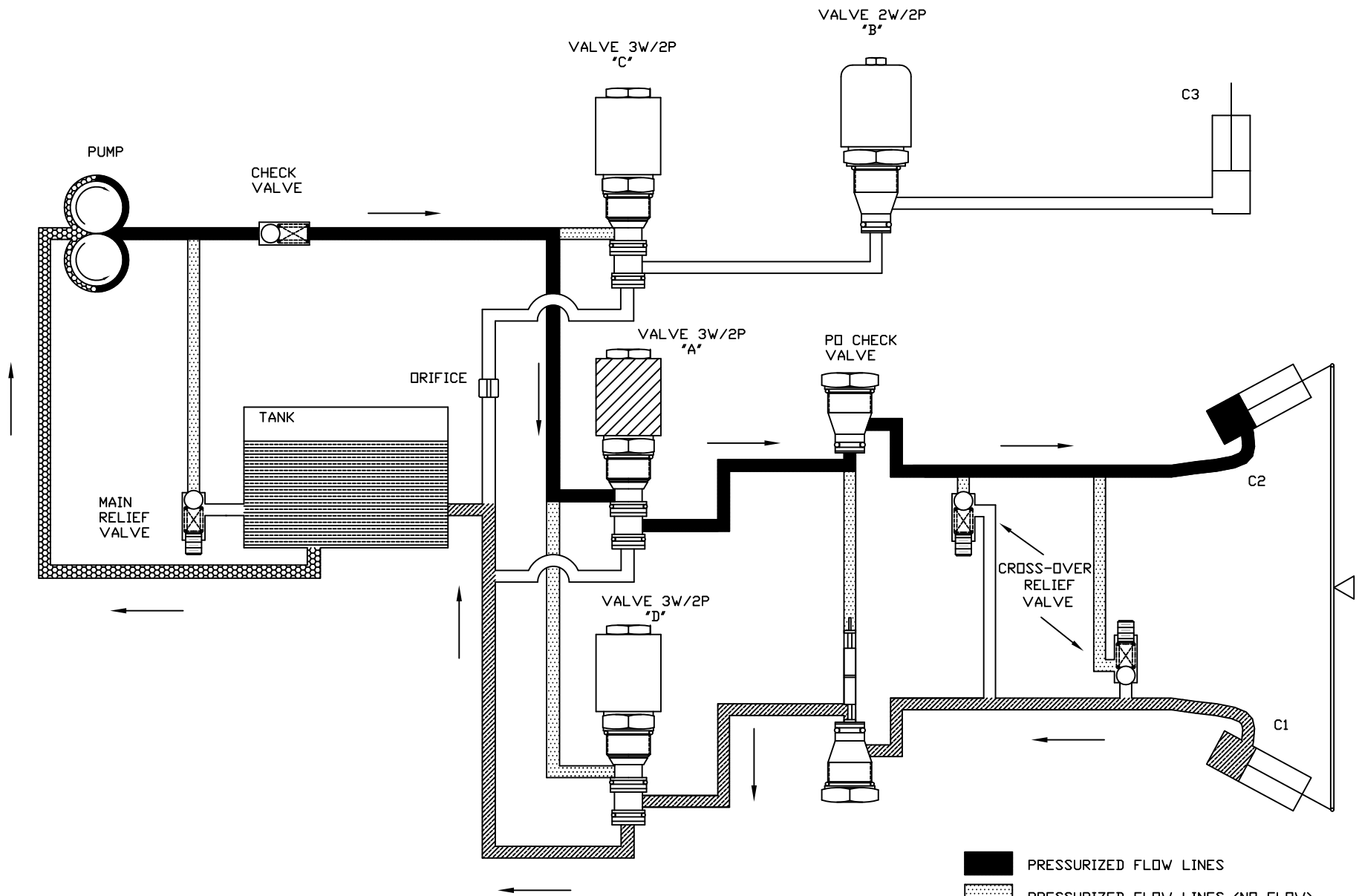

M3493
 EXTEND C2
 (ANGLE RIGHT)



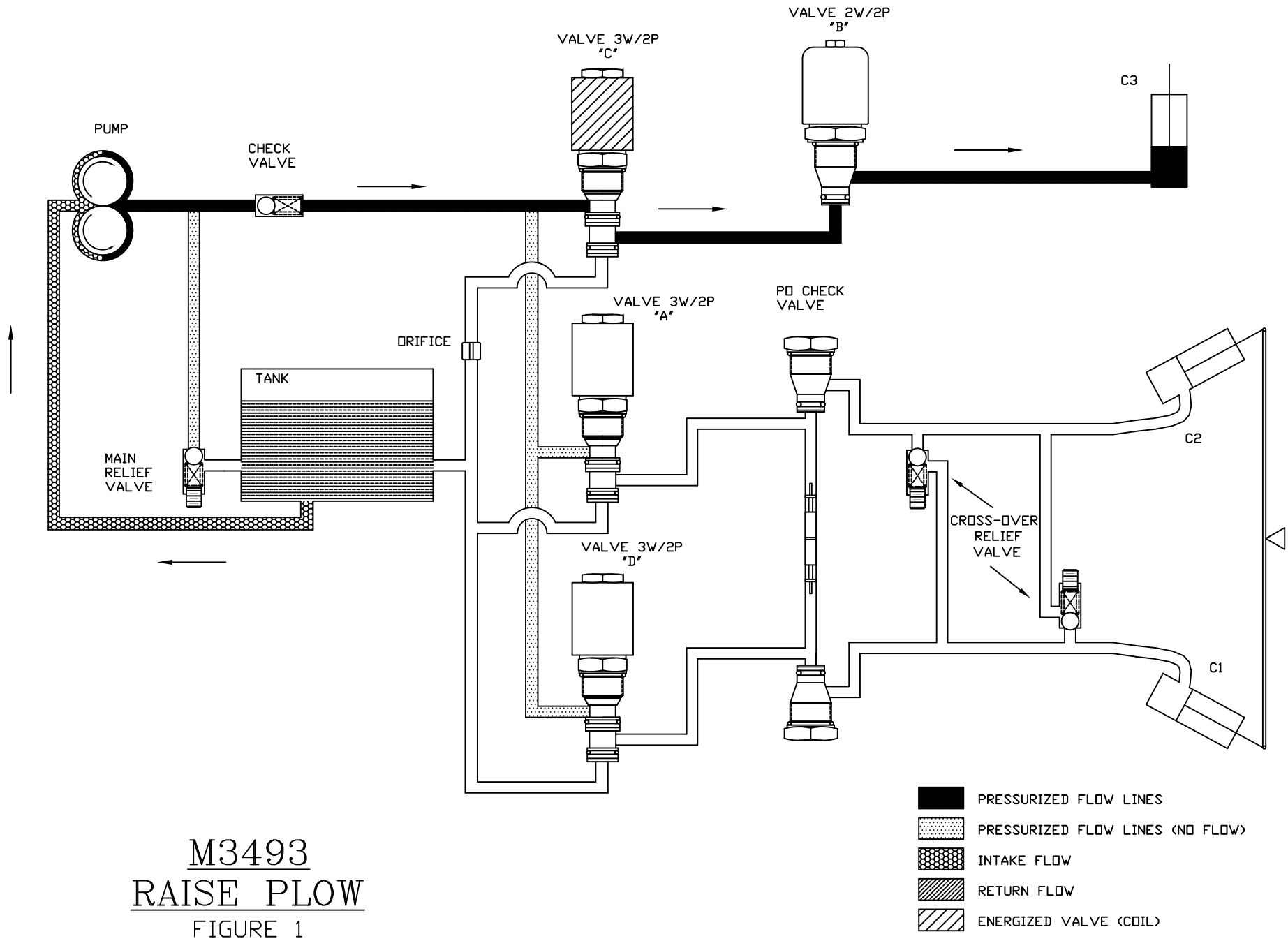

FIGURE 3

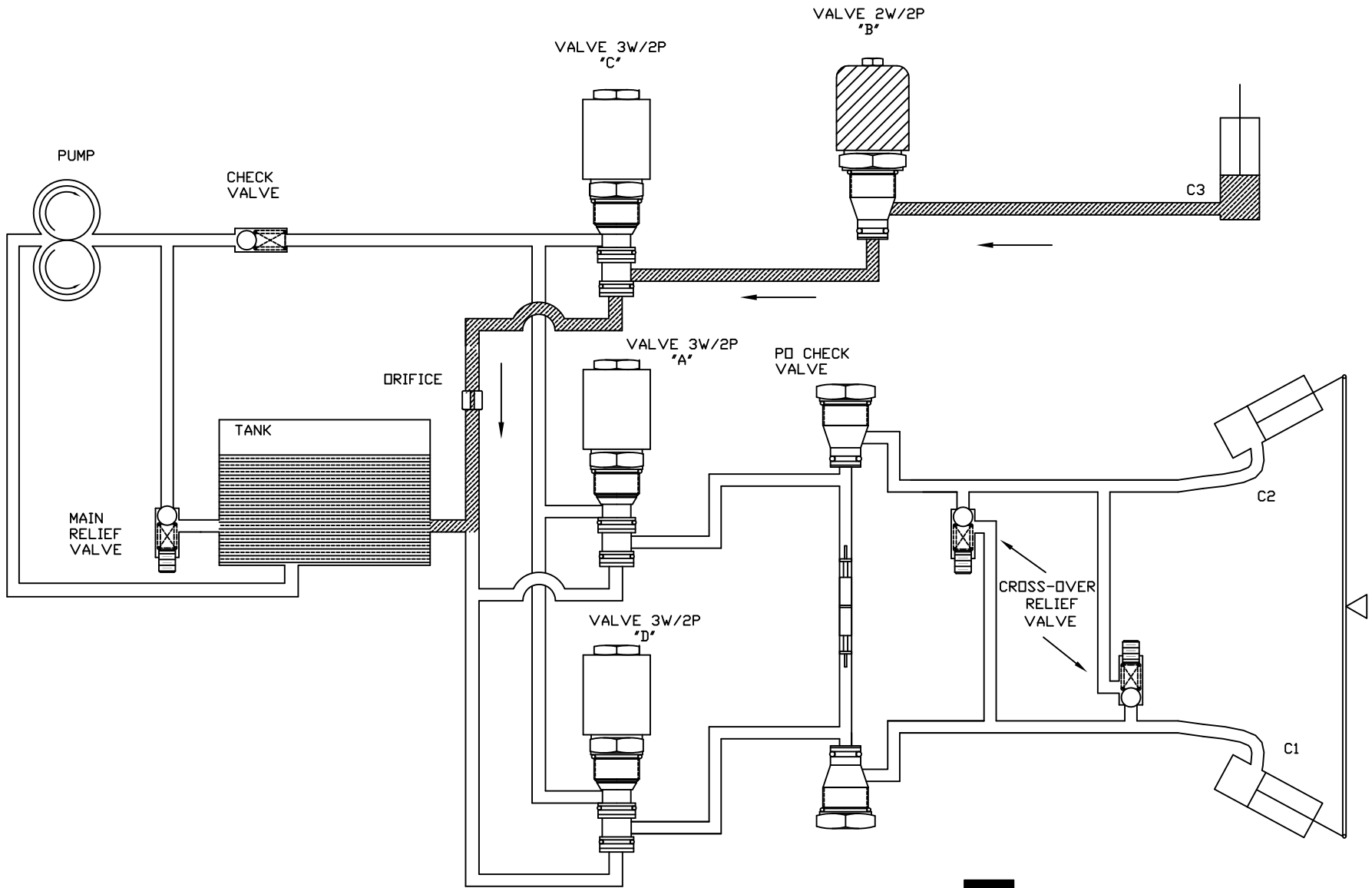

M3493
 RAISE PLOW
 FIGURE 1



M3493
 LOWER FLOW
 FIGURE 2

-  PRESSURIZED FLOW LINES
-  PRESSURIZED FLOW LINES (NO FLOW)
-  INTAKE FLOW
-  RETURN FLOW
-  ENERGIZED VALVE (COIL)

M3493 hydraulic installation instructions

(for electrical installation instructions check one piece harness 53617-M or multiplexing
installation 53618-M)
(it requires light kit 800084 or 800085 or 800086)

M3493 installation instructions

Warning:

- Top of battery needs to be protected. If positive side of battery is accidentally grounded person could be burnt or wiring system can be damaged, or battery gasses could explode causing injuries.
- Disconnect cable from negative battery terminal before starting installation.
- Always wear eye protection and protective clothing when working around hydraulic systems.
- Remove jewelry and objects that might conduct electricity while working on power units.
- Fluid under pressure can pierce the skin and enter the bloodstream causing death or serious injury.
- Hydraulic hoses and electrical cables (harnesses) must be tied and routed safely to avoid any damage and pinching (away from hot places, sharp objects etc.).

Note: Do not use Teflon tape on hydraulic fittings as it can easily jam valves and plug the filters in the system. **Use of fluid other than J13 will void warranty. Apply dielectric grease to all connections to prevent corrosion.**

Read also One piece harness installation / Multiplexing installation instructions before proceed with the installation below.

*For electrical installation read:
one piece harness installation 53617-M or multiplexing installation 53618-M / 53618-02-M.*

Hydraulic Installation:

1. Install hoses and fittings as per diagrams and pictures below.
2. Remove vent cap and fill reservoir with UNIVIS J13 (HVI 13) hydraulic oil. Do not use automatic transmission fluid in this system as it may lead to aeration of the oil in very cold weather conditions. Use of fluid other than J13 will void warranty.
3. Manually angle one section of the blade to one side (Curb side (CS)) before activating the power unit. Tighten hose – the fitting on the Curb Side cylinder.
The hose connection on the Driver Side cylinder must be loose (to let air out). Press the controller and angle the blade all the way to the Driver Side. Tighten hose – the fitting on the Driver Side cylinder. Fill up the reservoir, so that oil level is 1/2” from the top of the reservoir, and angle the blade to the curb side.
Move, operate, the blade up and down, left and right and refill it up as necessary.

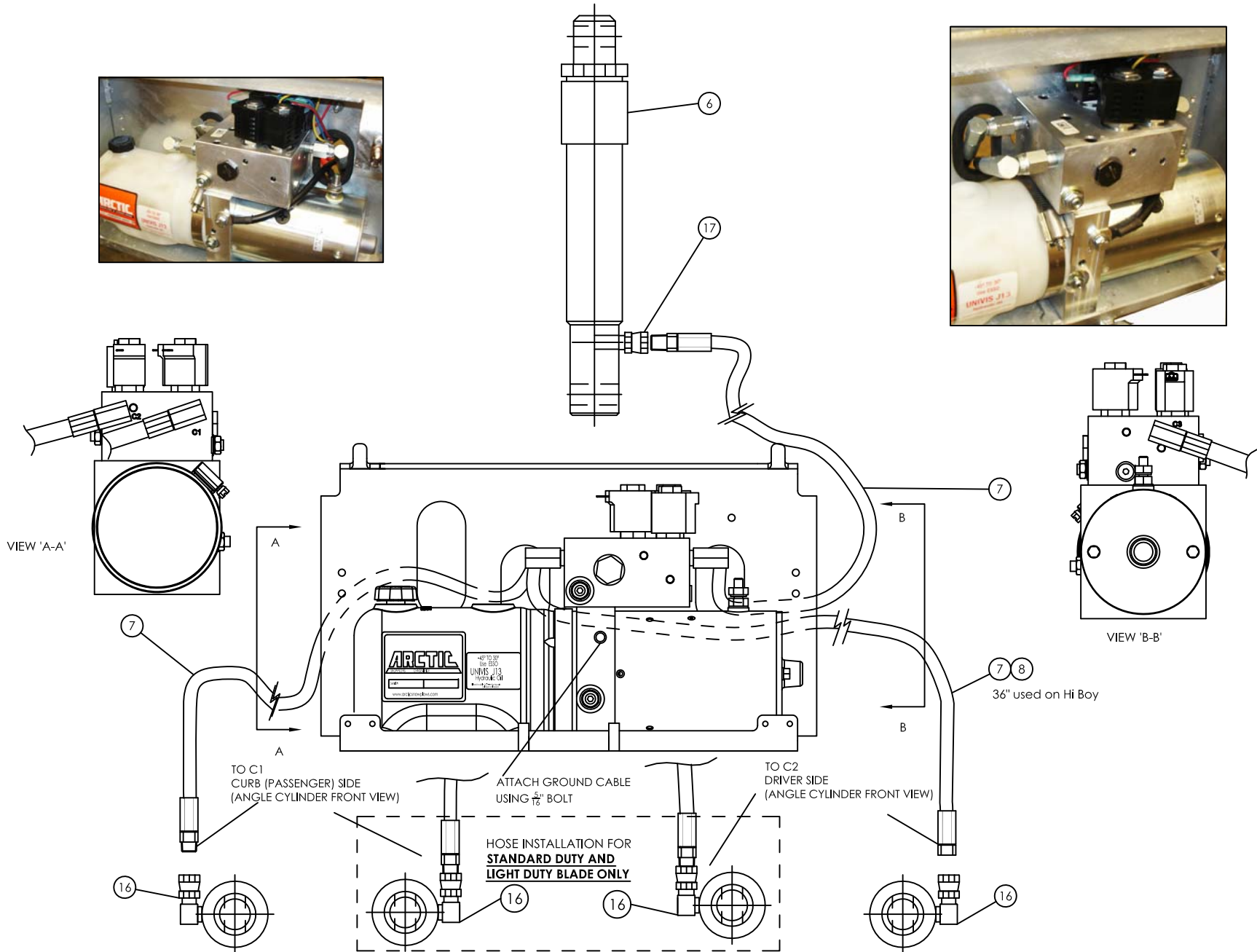
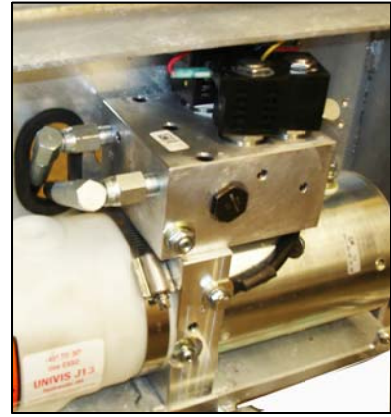

TO C1
CURB (PASSENGER) SIDE
(ANGLE CYLINDER FRONT VIEW)

ATTACH GROUND CABLE
USING 1/8" BOLT

TO C2
DRIVER SIDE
(ANGLE CYLINDER FRONT VIEW)

HOSE INSTALLATION FOR
STANDARD DUTY AND
LIGHT DUTY BLADE ONLY

36" used on Hi Boy

Power Unit Kit 53619-M, M3493 - Low Lift Frame (no harnesses)			
	Part#	Description	Quantity
1	M3493	M3493 Power Unit	1
2	53476-B	18" Cable Plug Assembly	1
3	53477-B	90" Ground Cable (Black)	1
4	53478-B	90" Power Cable (Red)	1
5	53420-C	Power Unit Cover	1
6	CS150-06.00-NRS	1.1/2"X6" Lift Cylinder	1
7	51904-M	29" Hose Assembly	3
8	53419-M-BB	Bolt Bag	1
9	51335-56-M	Battery Cable, 56"	1
10	51335-22-M	Battery Cable, 22"	1
11	53608-N	Circuit Breaker, Fuse 135 AMP	1
Bolt Bag, 53419-M-BB			
	Part#	Description	Quantity
12	52427-N	Red Terminal Protector	1
13	53560-A	Dummy Plug (Power & Ground)	1
14	52700-N	Grommet 1/8x2.1/8x2.7/8	2
15	490056-01	Dielectric Grease	1
16	HH-00790-002	90 Deg Swivel Elbow	2
17	HH-00794-003	1/4" Fitting	1
18	HH-00293-006	1/4-20x1 HHCS	1
19	HH-00294-001	1/4-20 Hex Nut	1
20	HH-00457-006	1/4 Lockwasher	1
21	HH-00293-049	3/8-16x1 HHCS	2
22	HH-00457-004	3/8 Lockwasher	2
23	HH-00293-026	5/16-18x3/4 HHCS	1
24	HH-00457-007	5/16 Lockwasher	1
25	HH-00341-004	3/8 Flatwasher	2
26	HH-00455-007	#8x3/4 Screw	4
Power Unit Kit 53620-M, M3493 - Hi Boy Lift Frame (no harnesses)			
	Part#	Description	Quantity
1	M3493	M3493 Power Unit	1
2	52870-C-GA	Pump Plate	1
3	52429-C	Cover	1
4	53476-B	18" Cable Plug Assembly	1
5	53477-B	90" Ground Cable (Black)	1
6	CS150-06.00-NRS	1.1/2"X6" Lift Cylinder	1
7	51904-M	29" Hose Assembly	2
8	51905-M	36" Hose Assembly	1
9	53478-B	90" Power Cable (Red)	1

10	52431-M-BB	Bolt Bag	1
11	51335-56-M	Battery Cable, 56"	1
12	51335-22-M	Battery Cable, 22"	1
13	53608-N	Circuit Breaker, Fuse 135 AMP	1
Bolt bag 52431-M-BB (M3593 Hi Boy)			
	Part#	Description	Quantity
14	52436-N	Grommet 1/4"X1.3/4x2.1/2	2
15	HH-00293-006	1/4-20x1 HHCS	1
16	HH-00790-002	90 Deg Swivel Elbow Fitting	2
17	HH-00794-003	1/4" Pipe To Pipe Fitting	1
18	HH-00340-017	5/16-18 Nyl. Ins.	4
19	HH-00341-004	3/8" Flatwasher	2
20	HH-00457-004	3/8" Lockwasher	2
21	HH-00294-001	1/4"-20 Hex Nut	1
22	HH-00457-006	1/4" Lockwasher	1
23	HH-00455-007	#8x3/4 SQ. DR. PAN	4
24	490056-01	1/2 Oz Tube Dielectric Grease	1
25	HH-00293-049	3/8-16x1 HHCS	2
26	HH-00971-043	5/16-18x1 Carriage	4
27	53560-A	Dummy Plug (Power & Ground)	1
28	52427-N	Red Terminal Protector	1
29	52700-01-N	Grommet 1/8 x 3 x 3.625	1
30	HH-00293-028	5/16"-18 x 1 HHCS	1
31	HH-00457-007	5/16" Lockwasher	1

Arctic Equipment Manufacturing Corporation reserves the right under its product improvement policy to change construction or design details and furnish equipment when so altered without reference to illustrations or specifications used.

M3493 Installation Instructions

53419-M

(multiple harness installation)

Warning

- Top of battery needs to be protected. If positive side of battery is accidentally grounded person could be burnt or wiring system can be damaged, or battery gasses could explode causing injuries.
- Disconnect cable from negative battery terminal before starting installation.
- Always wear eye protection and protective clothing when working around hydraulic systems.
- Remove jewelry and objects that might conduct electricity while working on power units.
- Fluid under pressure can pierce the skin and enter the bloodstream causing death or serious injury.
- Hydraulic hoses and electrical cables (harnesses) must be tied and routed safely to avoid any damage and pinching (away from hot places, sharp objects etc.).

Note: **Do not use Teflon tape** on hydraulic fittings as it can easily jam valves and plug the filters in the system. **Use of fluid other than J13 will void warranty. Apply dielectric grease to all connections to prevent corrosion.**

Read also Light installation instruction before proceed with installation bellow

1. Install red weather covers (4) on cable and plug assembly (2). Attach red lead to positive motor stud and black lead to pump base. Liberally coat connections with dielectric grease then slide cover over the eye on the end of the red cable.
2. Install power unit (1) with motor toward driver's side of truck (secure a power unit to the pump plate using 3/8" bolts on the back-use removable grade Loctite for these bolts also).
3. Route power unit harness through grommet in driver's side of mounting plate and secure using cable clamp (attached to power unit harness) and 1/4" x 1" bolt.
4. Mount solenoid (4) to metal surface in engine compartment, bending bracket if necessary. Be sure to locate the solenoid so that there is sufficient cable to reach to both the battery and the cable and plug assembly (2) on the power unit.
NOTE: Solenoid must be well grounded in order to function properly.
5. Slide weather cover (13) over power cable (5) and ground cable (6) and route through grille of truck leaving sufficient length to attach to the cable and plug assembly (2). Secure the red power cable (5) to the large terminal on the solenoid and the black ground cable (6) to the negative terminal on the battery.
6. Secure power cable (7) from other large terminal on solenoid to positive terminal on battery.
7. Plug intermediate harness (8) into power unit harness and follow battery cable routing toward firewall. Locate a pass through hole in the firewall near the driver's side of the truck. Route other end of intermediate harness (8) through the hole in firewall and attach control station.

NOTE: A smaller hole in the firewall can be used if the cable is fed into the engine compartment from the cab as the plug at the power unit end is smaller than at the control station end.

8. Attach white wire to ground, black wire to positive side of solenoid and brown wire to small terminal on top of the solenoid (4).

Note: Apply dielectric grease to all electrical connections. Assure that all electrical connections are attached and secured properly.

9. Neatly secure all excess cables and wires using tie straps. Silicone hole in firewall.

Note: Be sure all cables are properly protected from any sharp edges or hot or moving parts.

10. Install swivel elbows in ports, C1, C2 and C3 as shown on attached drawing.

11. Install two grommets as shown on the drawing.

12. Install hoses as shown on the drawing (secure hose to the pump plate).

13. Remove vent cap and fill reservoir with UNIVIS J13 (HVI 13) hydraulic oil. Do not use automatic transmission fluid in this system as it may lead to aeration of the oil in very cold weather conditions. Use of any fluid other than J13 will void warranty.

14. Manually angle one section of the blade to one side (Curb side (CS)) before activating the power unit. Tighten hose – the fitting on the Curb Side cylinder.

15. The hose connection on the Driver Side cylinder must be loose (to let air out). Press the controller and angle the blade all the way to the Driver Side. Tighten hose – the fitting on the Driver Side cylinder. Fill up the reservoir, so that oil level is 1/2” from the top of the reservoir, and angle the blade to the curb side.

16. Move, operate, the blade up and down, left and right and refill it up as necessary.

17. Apply die electric grease to all coil nuts and electrical connections to prevent corrosion and install power unit cover (9).

53419-M Power Unit Kit M3493 hose and fitting installation

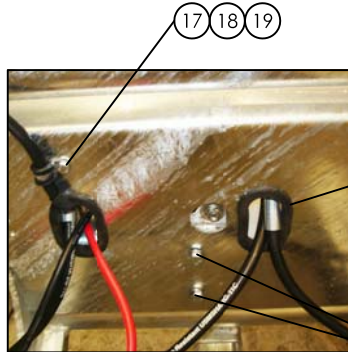

BACK VIEW

17 18 19
16
20 21
SECURE POWER UNIT
USING $\frac{3}{8}$ " BOLT AND
LOCKWASHER, APPLY
LOCTITE REMOVABLE GRADE

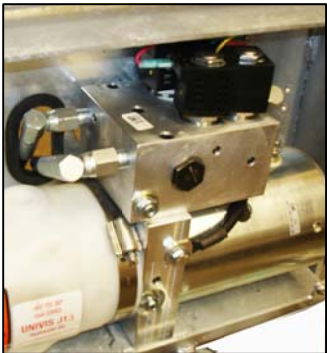

FRONT VIEW

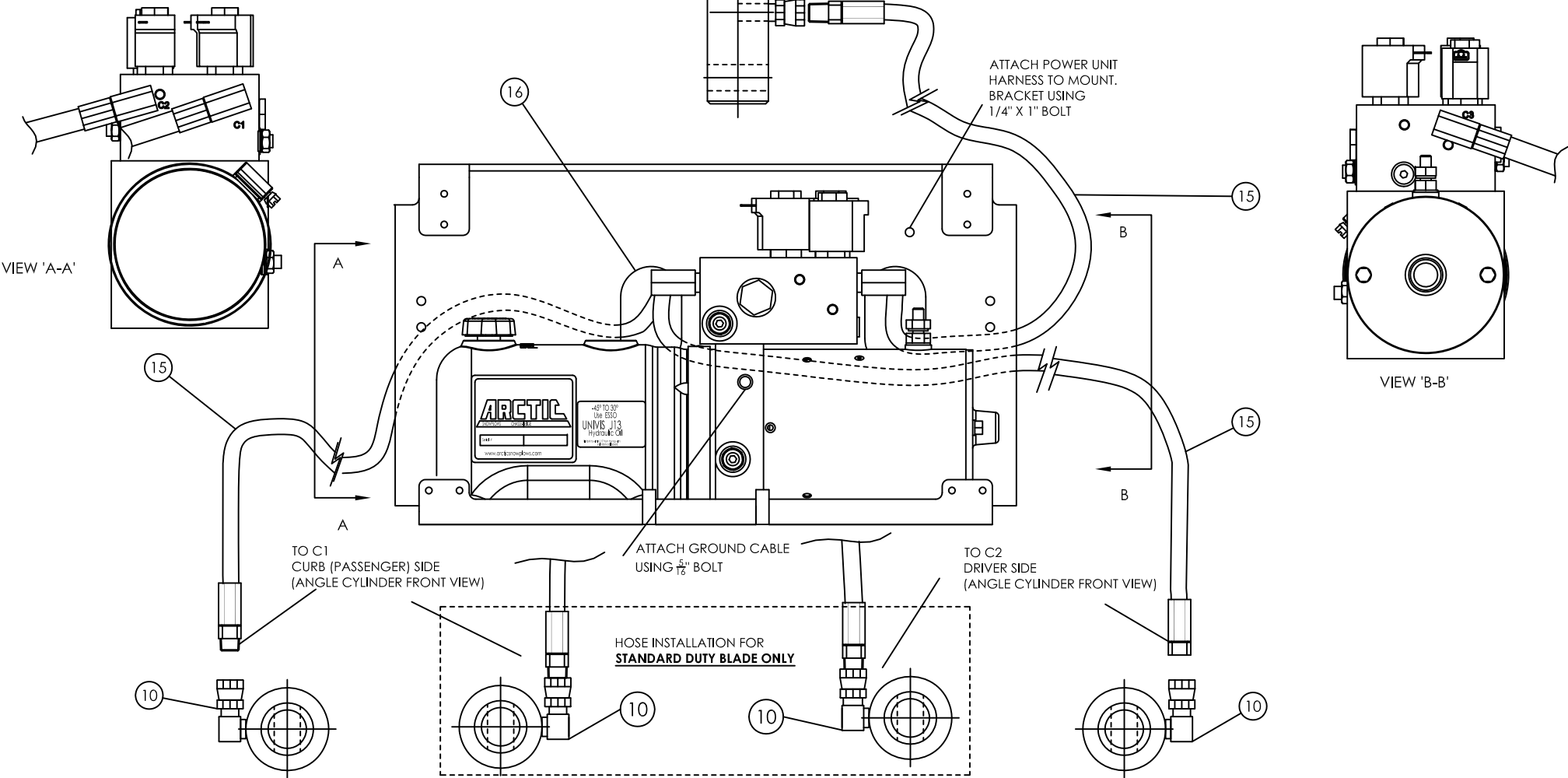

53419-M Power Unit Kit M3493 WIRING INSTALLATION

NOTES:
1) THE HARNESSES FPN0670 & FPN0457-SA ARE USED WITH ALL CONTROL BOXES: SWITCH TYPE FPN0455-SA (SHOWN).

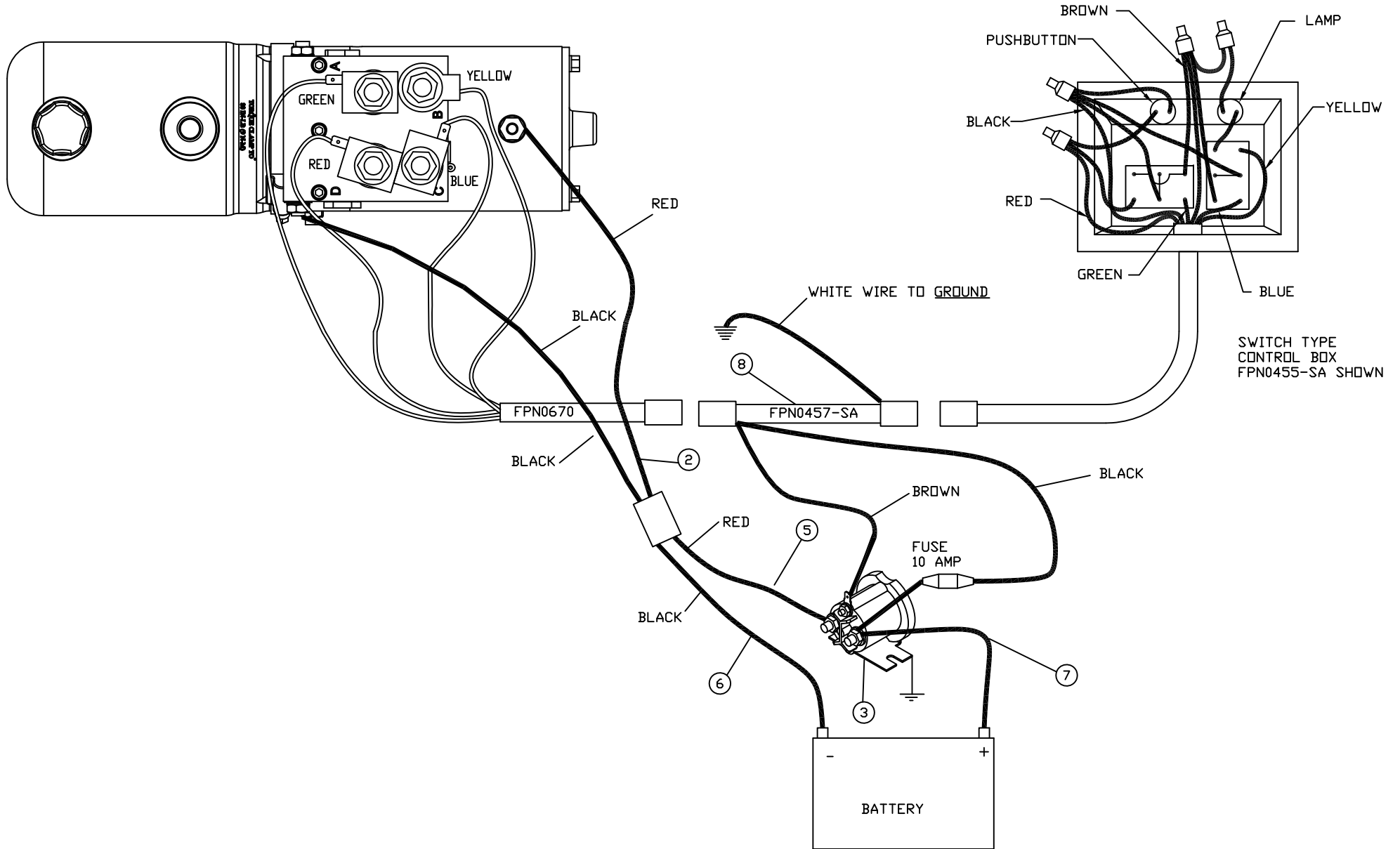

Power Unit Kit 53419-M			
Item	Part #	Description	Quantity
1	M3493	M3493 Power Unit	1
2	53476-B	Cable and Plug Assembly	1
3	FP17757	Solenoid	1
4	52427-N	Red Terminal Protector	1
5	53478-B	Power Cable 90"	1
6	53477-B	Ground Cable 90"	1
7	51335-22-M	22" Battery Power Cable	1
8	FPN0457-SA	Intermediate Harness	1
9	53420-C	Power Unit Cover	1
10	HH-00790-002	90 Deg Swivel Elbow	2
11	CS150-06.00-NRS	Lift Cylinder 1 1/2" x 6"	1
12	HH-00794-003	1/4" Pipe to Pipe Swivel	1
13	0203300	Weather cover for power and ground cable	1
14	52315-N	Dummy Plug for intermediate harness	1
15	51904-M	Hose Assembly 29"	3
16	52436-N	Grommet	2
17	HH-00293-006	1/4-20x1 HHCS	1
18	HH-00294-001	1/4-20 Hex nut	1
19	HH-00457-006	1/4 Lockwasher	1
20	HH-00293-049	3/8-16x1 HHCS	2
21	HH-00457-004	3/8 Lockwasher	2
22	HH-00293-026	5/16 x 3/4" HHCS	1
23	HH-00457-007	5/16 Lockwasher	1

Arctic Equipment Manufacturing Corporation reserves the right under its product improvement policy to change construction or design details and furnish equipment when so altered without reference to illustrations or specifications used.

M3493
Parts list(2011-2012)

POWER UNIT M3493
2011-2012

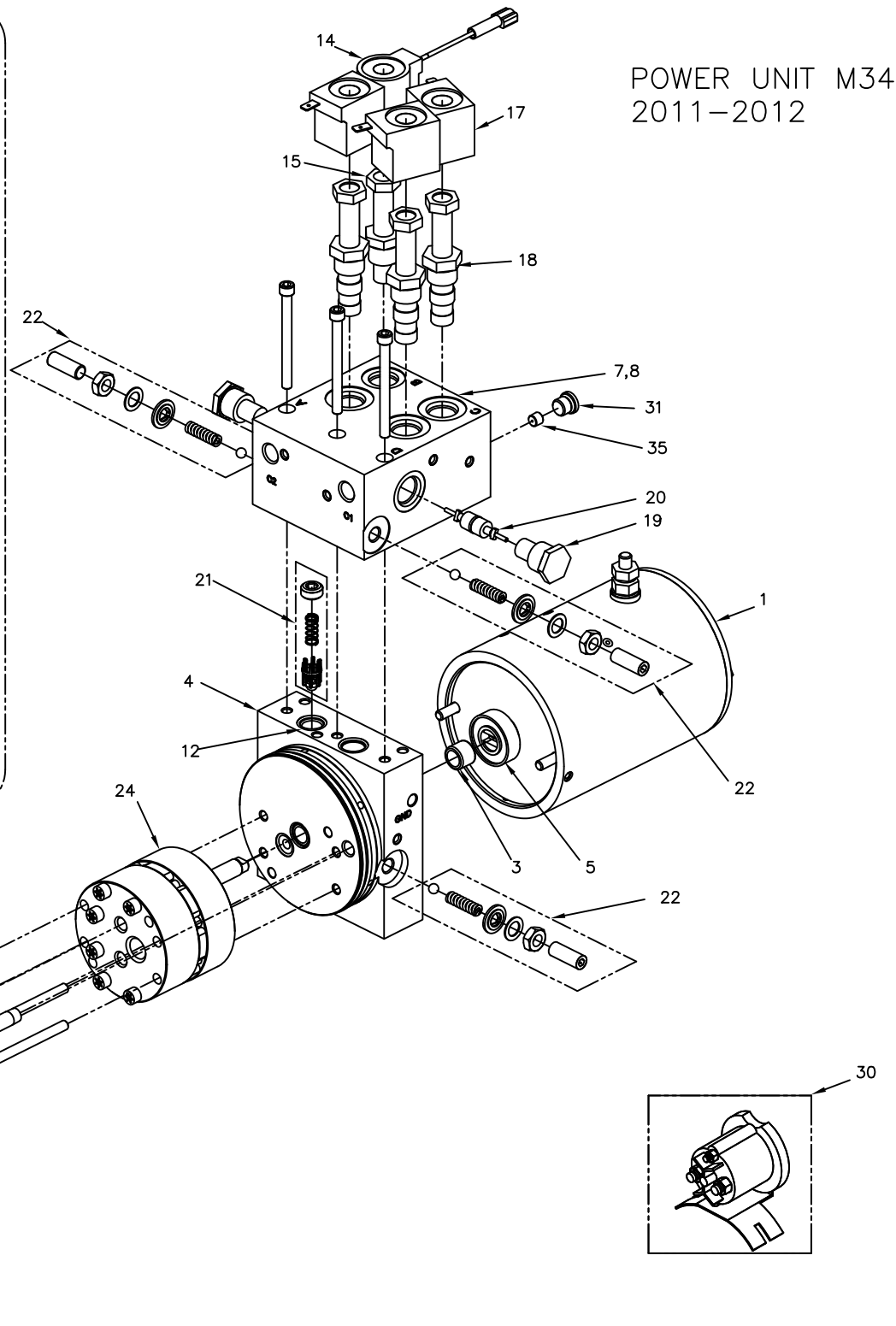
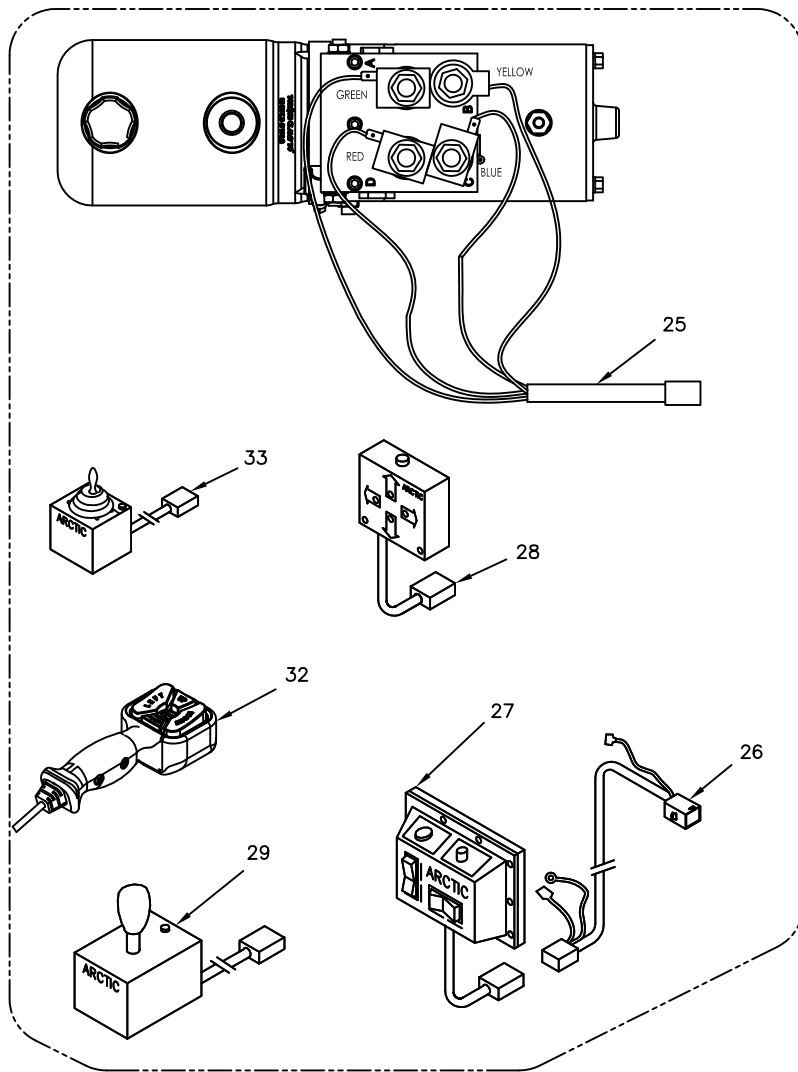

M3493 Power Unit Parts List for (2011-2012)			
	Part #	Description	Qty
1	FP8111	Motor, 12 VDC	1
2	FP2159	Pump Shaft Seal	1
3	FP7985	Needle Bearing (Pump Shaft to Pump Base)	1
4	FP21115	Pump base assembly, M3493	1
5	FP2318	Motor to Pump Base Bearing	1
6	FP6102	Reservoir	1
7	FP20752	Manifold assembly	1
8	FP20751	Manifold only	1
9	FP1209	Suction tube	1
10	FP13058	Return tube	1
11	FP1134	Suction filter	1
12	FP0118	O-ring, 5/8 x 3/4 x 1/16, -016	2
13	FP0490-D	Valve, #8 2W / 2P, valve assembly (14,15)	1
14	FP10861-D	Coil #8 2W / 2P,	1
15	FP10907-D	Valve, cartridge, 2W/2P	1
16	FP7249-D	Valve, #8, 3W / 2P, valve assembly (17,18)	3
17	FP18835-D	Coil, 12VDC, 3W/2P	1
18	FP0679-D	Valve cartridge, 3W / 2P	1
19	FP7217	Check Valve	2
20	FP7218	Piston	1
21	FP7526	Check valve kit	1
22	FP7527	Relief valve kit	1
23	FPN0572	Breather	1
24	FP12171-250-SA	Pump assembly kit	1
25	FPN0670	Harness valve section	1
26	FPN0457-SA	Harness center section	1
27	FPN0455-SA	Control station, rocker switch	1
28	FPN0478-SA	Control station, touch pad	1
29	52388-M	Large joystick	1
30	FP17757	Solenoid, switch	1
31	53220-N	30MS	1
32	53282-N	Handheld controller	1
33	53185-N	Small joystick	1
34	FP7900	Clamp	1
35	FP4371	Orifice	1

M3493

Parts list(2012+)

M3493 Power Unit Parts List (2012+)			
	Part #	Description	Qty
1	FP8111-I	Motor, 12 VDC	1
2	FP2159	Pump Shaft Seal	1
3	FP7985	Needle Bearing (Pump Shaft to Pump Base)	2
4	FP21115	Pump base assembly, M3493	1
5	FP2318	Bearing, Motor to Pump Base	1
6	FP6102	Reservoir, Plastic	1
7	FP21812	Manifold assembly	1
8	FP21811	Manifold only	1
9	FP1209	Suction tube	1
10	FP13058	Return tube	1
11	FP1134	Suction filter	1
12	FP0118	O-ring, 5/8 x 3/4 x 1/16, -016	2
13	FP0490-D	Valve, #8 2W / 2P, valve assembly (14,15)	1
14	FP10861-D	Coil #8 2W / 2P,	1
15	FP10907-D	Valve, cartridge, 2W/2P	1
16	FP7249-D	Valve, #8, 3W / 2P, valve assembly (17,18)	3
17	FP18835-D	Coil, 12VDC, 3W/2P	1
18	FP0679-D	Valve cartridge, 3W / 2P	1
19	FP7217	Check Valve	2
20	FP7218	Piston	1
21	FP7526	Check valve kit	1
22	FP7527	Relief valve kit	1
23	FPN0571	Breather	1
24	FPK12171-250-SA	Pump assembly kit	1
25	FPN0670	Harness valve section	1
26	FPN0457-SA	Harness center section	1
27	FPN0455-SA	Control station, rocker switch	1
28	FPN0478-SA	Control station, touch pad	1
29	52388-M	Large joystick	1
30	FP17757	Solenoid, switch	1
31	53220-N	Plug, SAE #4 (7/16")	1
32	53282-N	Handheld controller	1
33	53185-N	Small joystick	1
34	FP7900	Clamp (torque up to 80inlb)	1
35	FP2361	Orifice 1/16"	1
36	FP0120	O-ring, 1/2 x 5/8 x 1/16, -014	1
37	FP2352	O-ring, 3 3/4 x 4 x 1/8, -240	1
38	FP7732	Screw, spring retainer 9/16" -18	1
39	FP0130	Spring	1
40	FP18391	Poppet	1
41	FP13023	Cross over relief valve assembly	2
42	FP7899	Screw	1

M3493 Power Unit Parts List (2012+)

	Part #	Description	Qty
43	FP0386	Sealing nut	1
44	FP0147	Spring	1
45	FP1288	Plate	1
46	FP0379	Housing	1
47	FP0114	O-ring	1
48	FP0012	Ball	1
49	FP0378	Seat	1

HANDHELD CONTROL for STRAIGHT BLADE

1. Turn the ON/OFF switch on the control to the ON position. The control keypad will glow green, indicating the control is on.

NOTE: The ON/OFF switch can be used as an emergency stop when required.

2. Press the DOWN button for 1.3 seconds to engage the FLOAT mode. The FLOAT indicator light, located in the center of the keypad (logo), will change from green to red. To cancel the FLOAT mode, momentarily press the UP button.

FLOAT mode will automatically cancel after 17 minutes, and the FLOAT indicator light will turn back to green. To restart FLOAT mode, repeat step 2.

Blade Operation Time Outs

All control functions automatically time out (shut off) after a period of time. This helps reduce wear on the pump motor and prevent unnecessary battery drain.

All functions will time out after 8.0 seconds.

Automatic Shutdown

After being idle for approx. 22 minutes, the control will automatically turn off and the indicator light located at the center of the keypad (logo) will blink from red to green. To restart the control, turn the control OFF (ON/OFF switch) and then back ON.

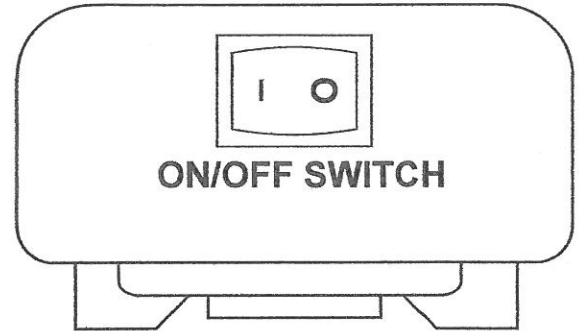

(LOCATED ON TOP OF HANDHELD CONTROL)

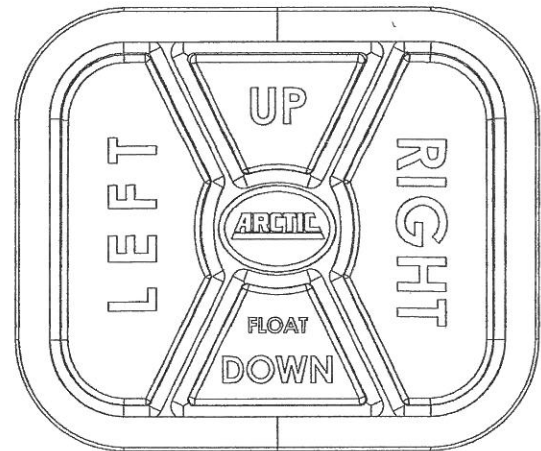

KEYPAD



WARNING

TO PREVENT
ACCIDENTAL ACTIVATION
OF PLOW, TURN PLOW
OFF WHEN NOT IN USE

Troubleshooting flow chart for power unit M3493

Safety and warnings

Servicing the snowplow (hydraulic power system, hoses, hydraulic cylinders, controllers, wiring harnesses, lights, blade frame, blade moldboard, A-frame, quadrant, lift frame and vehicle undercarriage) without special tools and knowledge could result in personal injury. See an authorized Arctic dealer for service.

- Fluid under pressure can pierce the skin and enter the bloodstream resulting in serious injury or death.
- Eye protection and protective clothing must be worn when working on any portion of the snowplow.
- Remove any jewellery (rings, bracelets, watches, necklaces) that could conduct electricity while working with electrical system.
- Lifted blade should be securely propped or immobilized while working on it or any other suspended part so it cannot fall.
- Do not operate blade when anyone is within a 10 foot radius of it.
- Use of any fluid other than J13 will void warranty

Tips

- Pump shaft can be turned freely (smoothly) using two fingers. If it can't be turned replace pump. Proper pump rotation is clockwise looking from the motor end.
- Use a screwdriver to check magnetism of solenoid coils. Place screwdriver on the nut securing the coil and have the switch operated. Strong magnetic attraction should be felt.
- Measure pump pressure at an angle hose (at full angle) it has to be 2000 psi (assuming that cross over relief valve setting is 2500 psi, if X-over relief valve setting is less than relief valve setting pressure gage will read lowest reading). The most accurate reading of system pressure is reading pressure on lift cylinder. When testing or making adjustments on the relief valve the system must be "dead headed" (cylinder at full stroke or in a position where cylinder movement is zero).
- AMP draw of motor should be measured at maximum raise or maximum angle when motor is running at 2000 psi.
- Use volt meter or test light to test for power in a harness or continuity in a switch. A test light is simply a light bulb which has one end connected by a wire to an alligator clip and the other end connected to a metal probe. It is used to check the electrical circuit when the battery is connected to the system. The alligator clip is grounded and the light glows when the probe comes in contact with a "live" electrical component.
- Do not screw cartridge valves into cavity too fast; use a back and forth motion and have O-rings well lubricated.

-Clean all parts thoroughly before assembly and lubricate with clean oil.

-Do not use Teflon tape on hydraulic connections as it can easily jam the valves and plug the filters in the system, use pipe sealant. Never apply pipe sealant at the end of fitting, always 2- 3 threads back.

-X-over pressure could be set using hand (hydraulic) pump. Example: If you want to set the pressure at x-over X1 insert hand pump hose in the C1 port together with pressure gauge. Loosen the jam nut and turn adjusting screw clockwise a turn or two and watch the gauge; if it goes up, continue to turn the screw until the required setting is reached. Retighten the jam nut. To set X-over X2 repeat the same steps as setting X1.

To adjust relief valve:

-Loosen jam nut counter-clockwise. Turn screw clockwise to increase pressure or turn screw counter-clockwise to decrease pressure. Tighten jam nut clockwise to 50in.lb. torque. Check system pressure after jam nut is tight. Readjust pressure if screw is moved during tightening of jam nut.

Specification:

-Max Amp Draw 220 AMP (AMP draw of motor should be measured at maximum raise or maximum angle when motor is running at pressure setting at 2000 psi).

Note: Do not operate motor continuously for more than 30 sec.

-Relief valve setting 2000 psi.

-X-over relief valve setting 2500 psi.

-Troubleshooting tips

- Motor does not operate.

- Motor operates continuously

- Snow plow does not raise.

- Snow plow raises up very slowly.

- Snow plow will not lower.

- Snow plow leaks down.

- Snow plow angles before going up when up switch is pressed.

- Snow plow when is fully angled going up when angle switch is pressed.

- Snow plow does not angle to right.

- Snow plow does not angle to left.

Note: Quick couplers are an optional item. If unit is not equipped with quick couplers, disregard troubleshooting steps involving them.

For Multiplexing issues please contact Arctic Equipment.

MOTOR DOES NOT OPERATE M3493

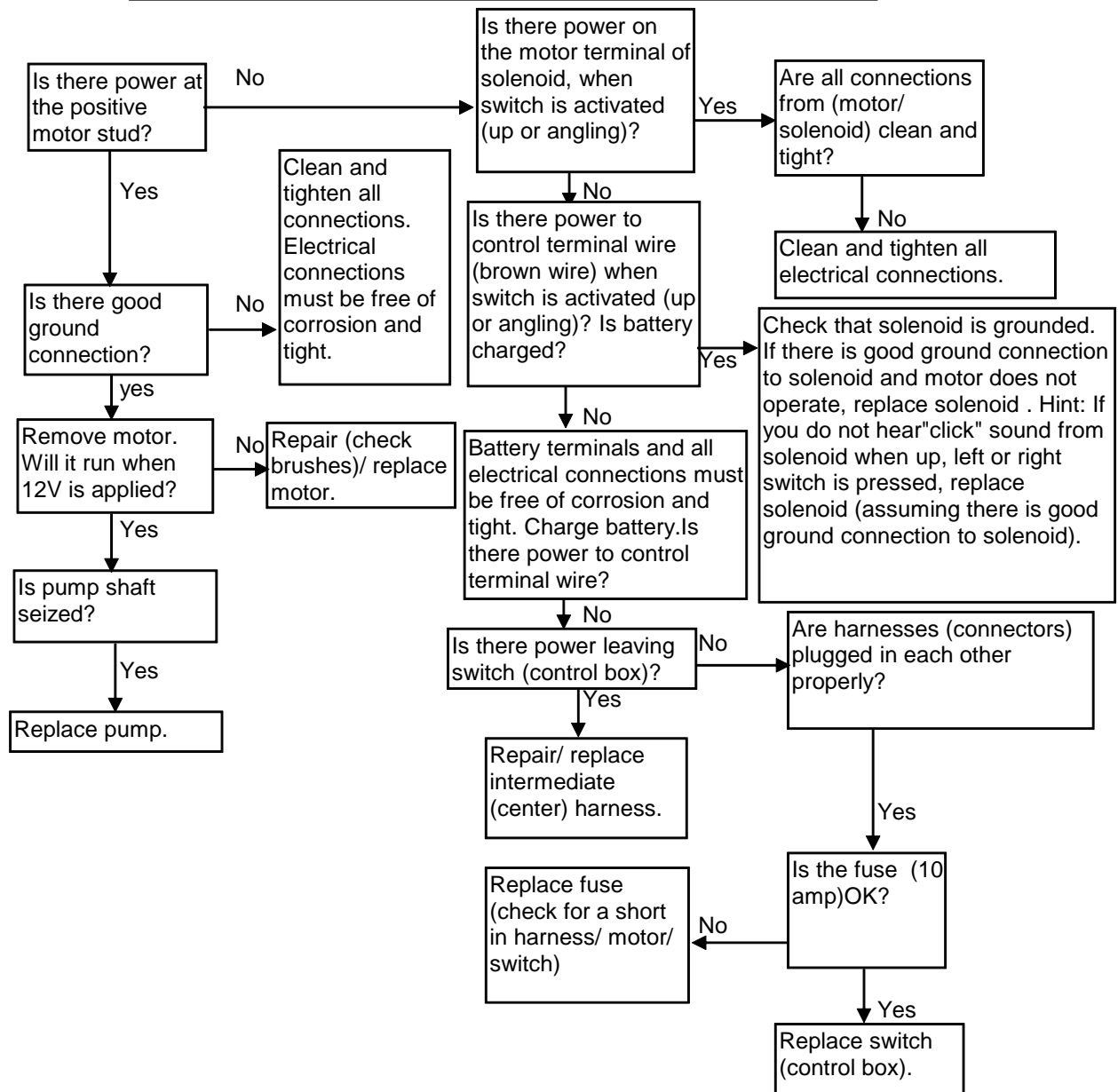

MOTOR OPERATES CONTINUOUSLY M3593

If motor operates continuously, change solenoid.

SNOW PLOW DOES NOT RAISE M3493

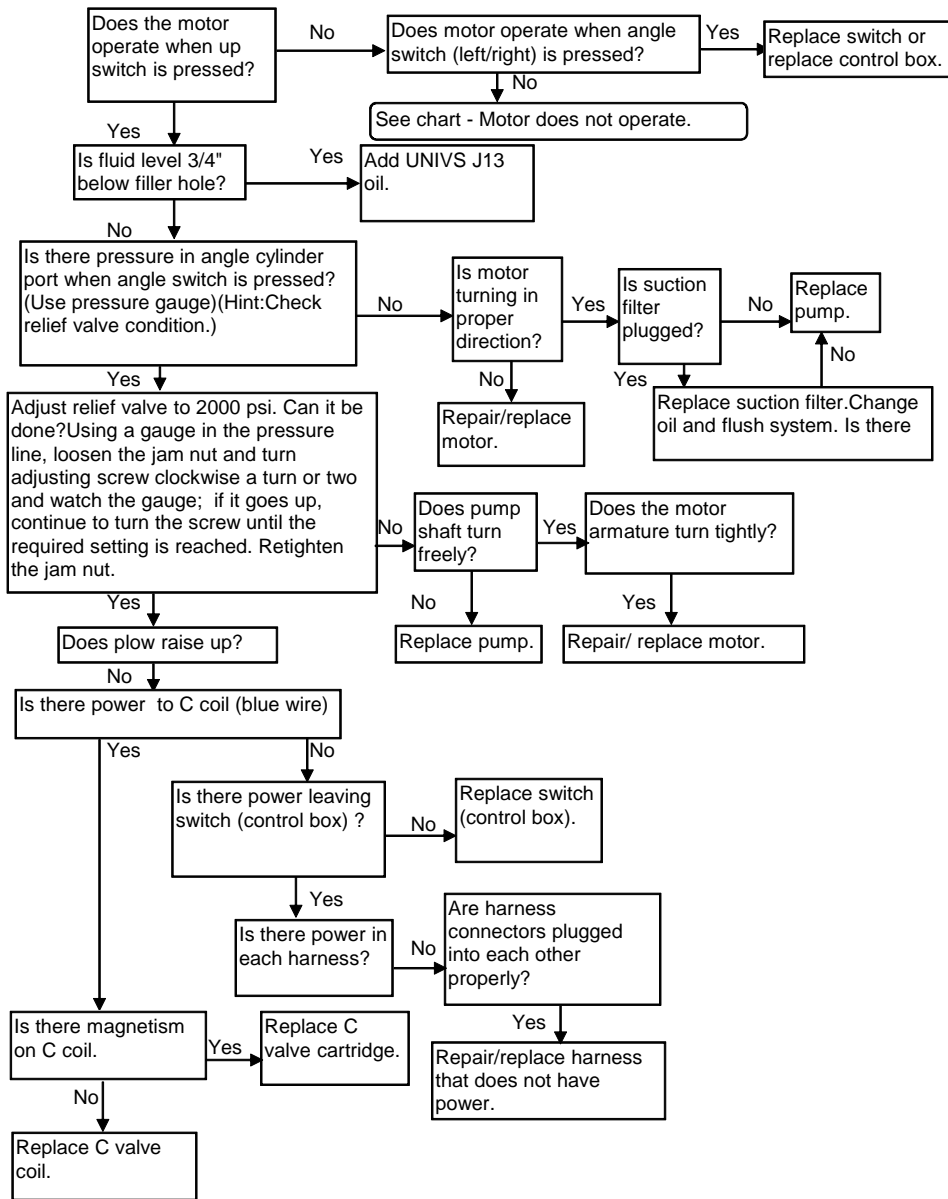

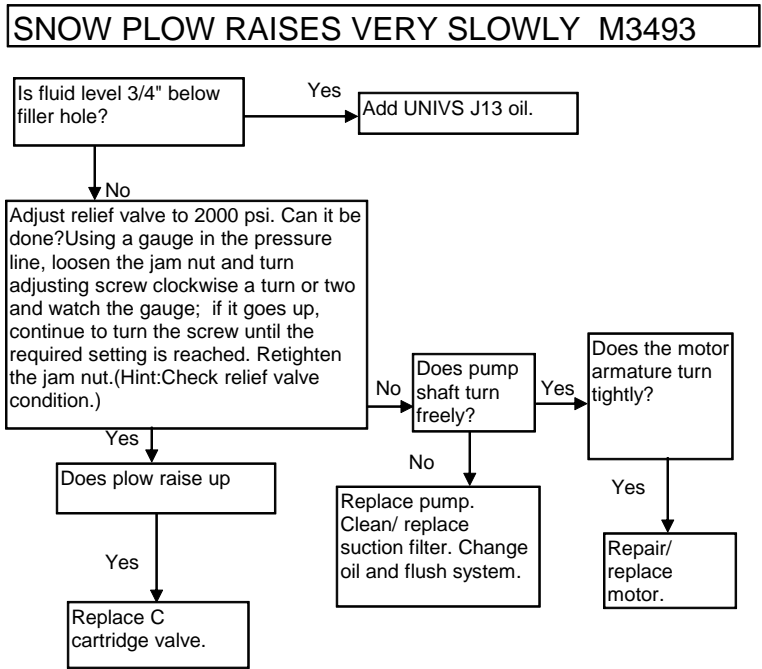

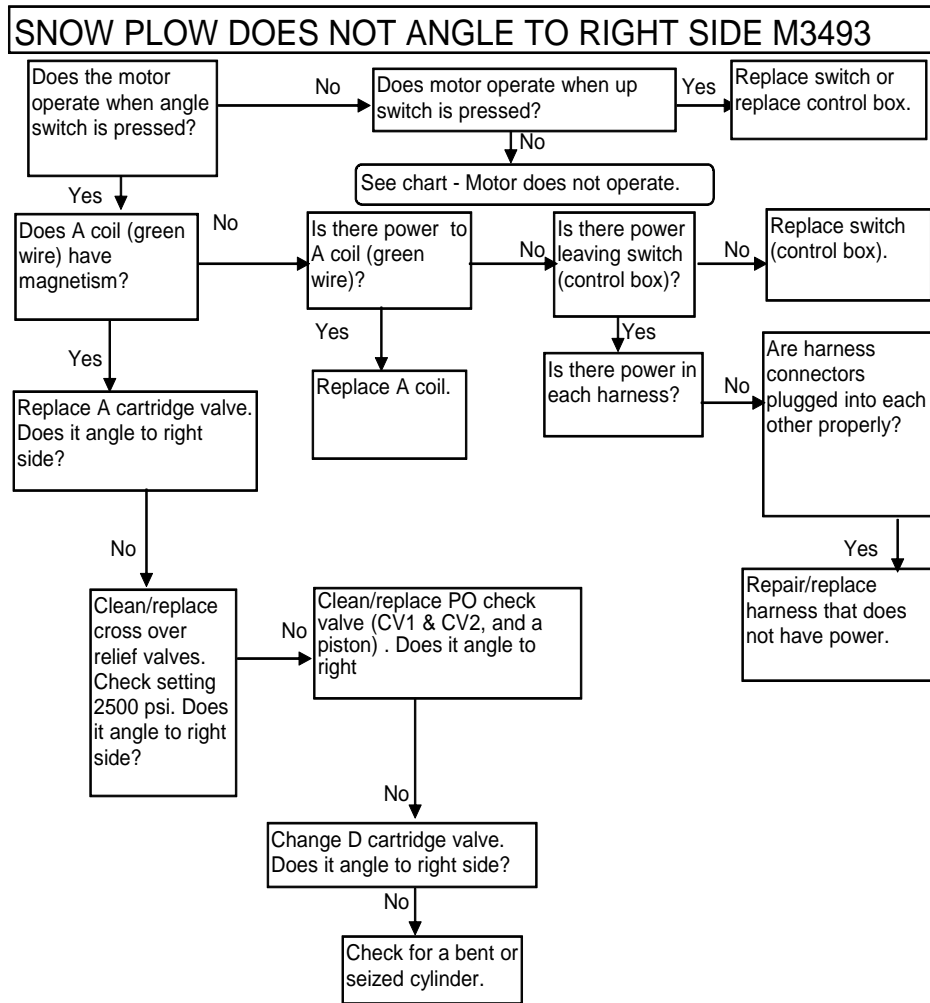

Note: Before start troubleshooting check that plow moves up and down. If plow does not move up and down see "plow does not raise".

SNOW PLOW DOES NOT ANGLE TO LEFT SIDE M3493

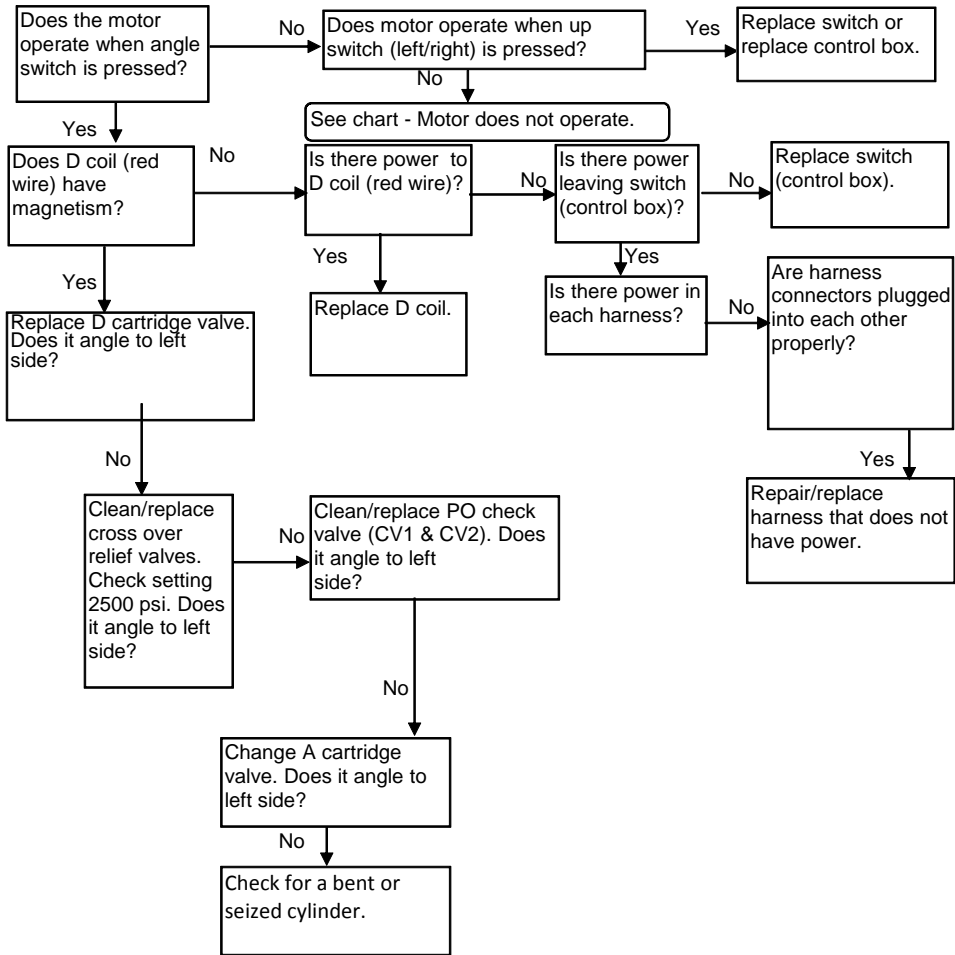

Note: Before start troubleshooting check that plow moves up and down. If plow does not move up and down see "plow does not raise".

PLOW DOES NOT HOLD ANGLE M3493

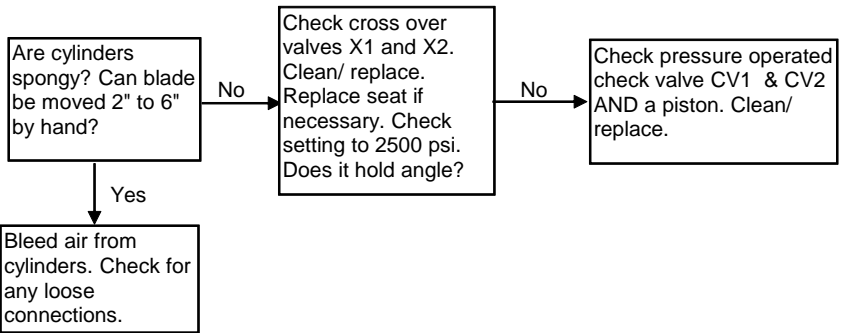

SNOW PLOW WILL NOT LOWER M3493

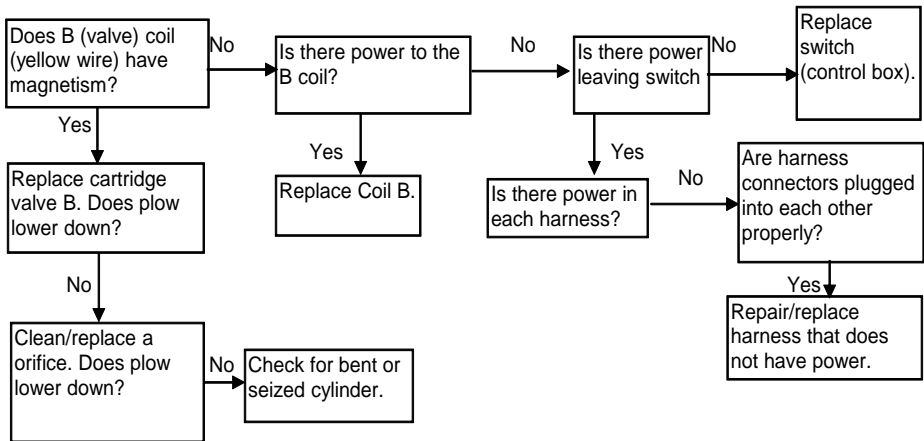

SNOW PLOW LEAKS DOWN M3493

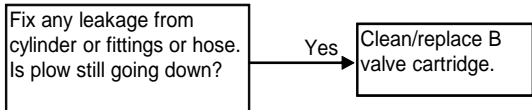

SNOW PLOW ANGLES BEFORE GOING UP WHEN UP SWITCH IS PRESSED M3493

If snow plow angles left before going up change D valve and if snow plow angles to right side change A valve.

SNOW PLOW WHEN FULLY ANGLED GOES UP (WHEN ANGLE SWITCH IS PRESSED) M3493

Change C Valve cartridge.

Arctic Equipment Manufacturing Corporation reserves the right under its product improvement policy to change construction or design details and furnish equipment when so altered without reference to illustrations or specifications used.