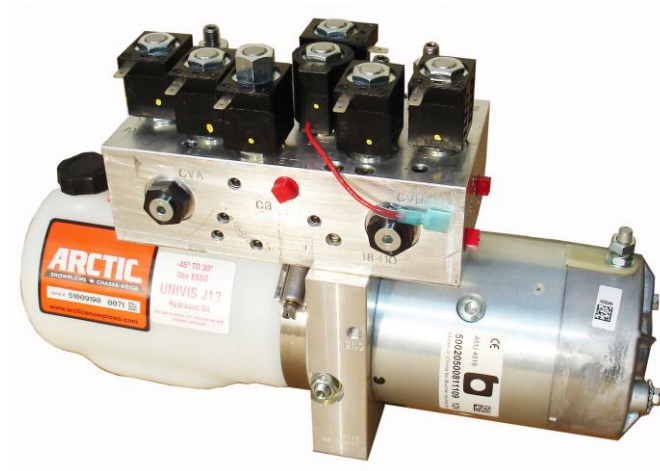

Table of Contents M3500V

Operating information.....2
Hydraulic Operational Diagrams.....7
Hydraulic Installation Instructions.....17
Installations Instructions prior to 2013.....21
Parts List prior to 2012.....28
M3500 V parts list after 2012.....34
Handheld Controller for V blade.....39
Troubleshooting flowchart for power unit.....40
Hydraulic Jack Installations.....57

M3500V

Operating Information



General Information about Power Unit M3500V

Warranty Identification

For purposes of warranty consideration, recording the serial number of the power unit is necessary. This serial number is displayed on a reservoir of the power unit.

Maintenance

Under normal operating conditions, the M3500V should not require servicing during the plowing season, provided post season maintenance has been carried out. Greasing electrical connection periodically is recommended to prevent corrosion.

It is recommended that after every season the hydraulic fluid to be changed. The replacement fluid recommended is **UNIVIS J13 (HVI 13)** hydraulic fluid. Automatic transmission fluid is not recommended for this system and may lead to aeration of the oil in very cold weather conditions. **Use of fluid other than J13 will void warranty.** The oil level in the reservoir is to be within 3/4" from the top surface (when lift cylinder is collapsed).

When draining the hydraulic fluid, the hoses at the cylinders should be disconnected and drained.

Electrical System

Frequently problems develop due to an undersized electrical charging and storage system. Generally, the heavier the usage, the heavier the system should be. For heavy usage and in the case where a number of other devices are run off the battery simultaneously, heavier ratings are strongly recommended.

Electric Motor

The 8111-I electric motor is a two pole electromagnetic motor, consisting primarily of an armature/commutator, two field coils, four brushes in a brush holder set, and a tubular steel body with cast endcap. Although the motor is grounded through the body, an additional grounding stud is provided on the motor body.

The power unit with this motor is equipped with the 05 gear pump. This combination of pump and motor offers optimum performance.

Hydraulic Pump

The hydraulic pump converts mechanical energy transmitted by the prime mover (in this case a 12 volt DC electric motor) into hydraulic energy. The hydraulic energy is due to flow (kinetic energy) and pressure (potential energy). The rate of energy output is expressed in horsepower.

At the inlet, as the gears un-mesh, the volume in the cavity increases thereby causing fluid to enter. This fluid is then carried between the gears and the housing to the other side of the gears

into the outlet cavity. At this point the gear teeth mesh. The outlet cavity volume decreases, causing fluid to flow into the system. Note that without a load, the pressure at the outlet port is nil.

The pressure at the outlet of the pump is due to external loads placed on the system. These loads can be transmitted through cylinders and linear actuators as well as hydraulic motors and rotary actuators. In practice, system components by virtue of orifice and line sizes, offer some resistance to the flow of fluid. This translates into pressure at the outlet of the pump.

Valve Information

Pressure Relief Valve

The pressure relief valve consists of a ball, a retaining spring and a seat. The ball is exposed to the pressure in the outlet line from the pump. This pressure acting on the exposed area of the ball, causes a force on the retaining spring. When the pressure is such that the force on the ball exceeds the force in the spring (due to a preset amount of precompression) the ball lifts off the seat and the fluid from the outlet of the pump is allowed to flow back to the reservoir. The “standard relief valve setting” for the M3500V is 1500 psi.

Directional Valves

The M3500V circuit contains 7 directional valves identified as ‘A1’, ‘A2’, ‘B’, ‘C’, ‘D1’, ‘D2’ and ‘E’.

Valves ‘A1’, ‘A2’, ‘C’, ‘D1’ and ‘D2’ are 3 way/ 2 position spool valves. Valve ‘B’ is a 2 way/ 2 position normally closed poppet valve and valve ‘E’ is 2 way/ 2 position normally open poppet valve. A basic directional valve consists of a valve cartridge and a coil. Inside the cartridge valve, an armature is attached to the valve mechanism.

The coil consists of a wire wrapped around a spool. When power is applied to the coil (the coil is energized), the magnetic field created by coil pulls the armature into the coil. The armature shifts the valve mechanism into the energized position. When power is removed from the coil, a spring inside the valve cartridge pushes the armature and valve mechanism to the de-energized position.

Directional Valve ‘B’

Valve ‘B’ is a 2 way/ 2 position normally closed poppet valve which is used for lowering the plow. In the de-energized position, valve B acts as a check valve allowing pump flow to the lift cylinder but preventing return flow from the lift cylinder to the reservoir. Energizing valve ‘B’ opens the valve and allows flow from the lift cylinder to the reservoir thereby lowering the plow. Note: the lift cylinder is connected to C3.

Directional Valves A1’, ‘A2’, ‘C’, ‘D1’, ‘D2’

Directional Valves ‘A1’, ‘A2’, ‘C’, ‘D1’ and ‘D2’ are 3 way/ 2 position spool valves. Directional Valve ‘C’ operates the lift cylinder on C3 port. Directional Valves ‘A1’, ‘A2’ and ‘D1’, ‘D2’ operate the left and right angling double acting cylinders.

Valves 'A1' and 'A2' operate the angling cylinder on the curb side of vehicle on C1 and C2 port. Valves 'D1' and 'D2' operate the angling cylinder on the driver side of vehicle on C4 and C5 port. In the de-energized position, the valves block flow from pump to the cylinder but allow return flow from the cylinder to the reservoir. In the energized position, flow from the pump to the cylinder is permitted but flow from the cylinder to the reservoir is not.

Directional Valve 'E'

Valve 'E' is a 2 way/ 2 position normally open poppet valve. In the de-energized position, valve 'E' allows flow that comes from C4 and C1 ports of the angling cylinders to the reservoir. When valve 'E' gets energized (it gets energized only when blade is to be angled to the left or to the right), the valve gets closed and allows flow from the angle cylinder port C1 to be directed to second angle cylinder port C4 and vice versa. Valve 'E' **must be energized (activated) ONLY** when plow is to be angled completely to the left or to the right (valve 'E' gets energized pressing trigger switch on the handle of the joystick).

Cross over relief valve

The cross over relief valves are provided to protect the valves and manifold from the pressure spikes created when the plow strikes an object. The cross over relief valves are similar in construction to a regular direct acting relief valve. Cross over valves when activated, bleed fluid from one port to another or to the reservoir. In this manner the angling cylinders, the plow frame, and the truck frame are offered some protection from the normal impact forces associated with plowing. Striking a fixed object while plowing at high speeds will damage the cylinders and perhaps the plow. The cross over relief valves are adjustable and are normally set at about 3,000 psi.

Pilot Operated (PO) Check Valve 'CVA' and 'CVD'

A dual pilot operated check valve (PO Check Valve) is provided on ports C1 and C2 and on ports C4 and C5 to hold the plow at the desired angle. Without the PO Check valves, leakage through directional valves 'A1', 'A2', 'D1' and 'D2' would allow the plow to drift.

Without pilot pressure, a pilot operated check valve (PO check valve) allows flow in only one direction. In the free flow direction, oil flowing through the valve lifts the poppet of the seat. In the opposite direction, returning oil pushes the poppet against the seat thereby blocking flow. When pressure is applied to the pilot piston, the poppet is lifted off the seat and flow in both directions is permitted.

Handheld Controller

The M3500V uses handheld control with following operations: raise, lower, angle right, angle left, vee, scoop, right blade section retracted, right blade section extended, left blade section retracted and left blade section extended.

Arctic Equipment Manufacturing Corporation reserves the right under its product improvement policy to change construction or design details and furnish equipment when so altered without reference to illustrations or specifications used.

LIFT CYLINDER
(EXTEND TO LIFT)

ANGLE CYLINDER
(DRIVER SIDE)

ANGLE CYLINDER
(CURB SIDE)

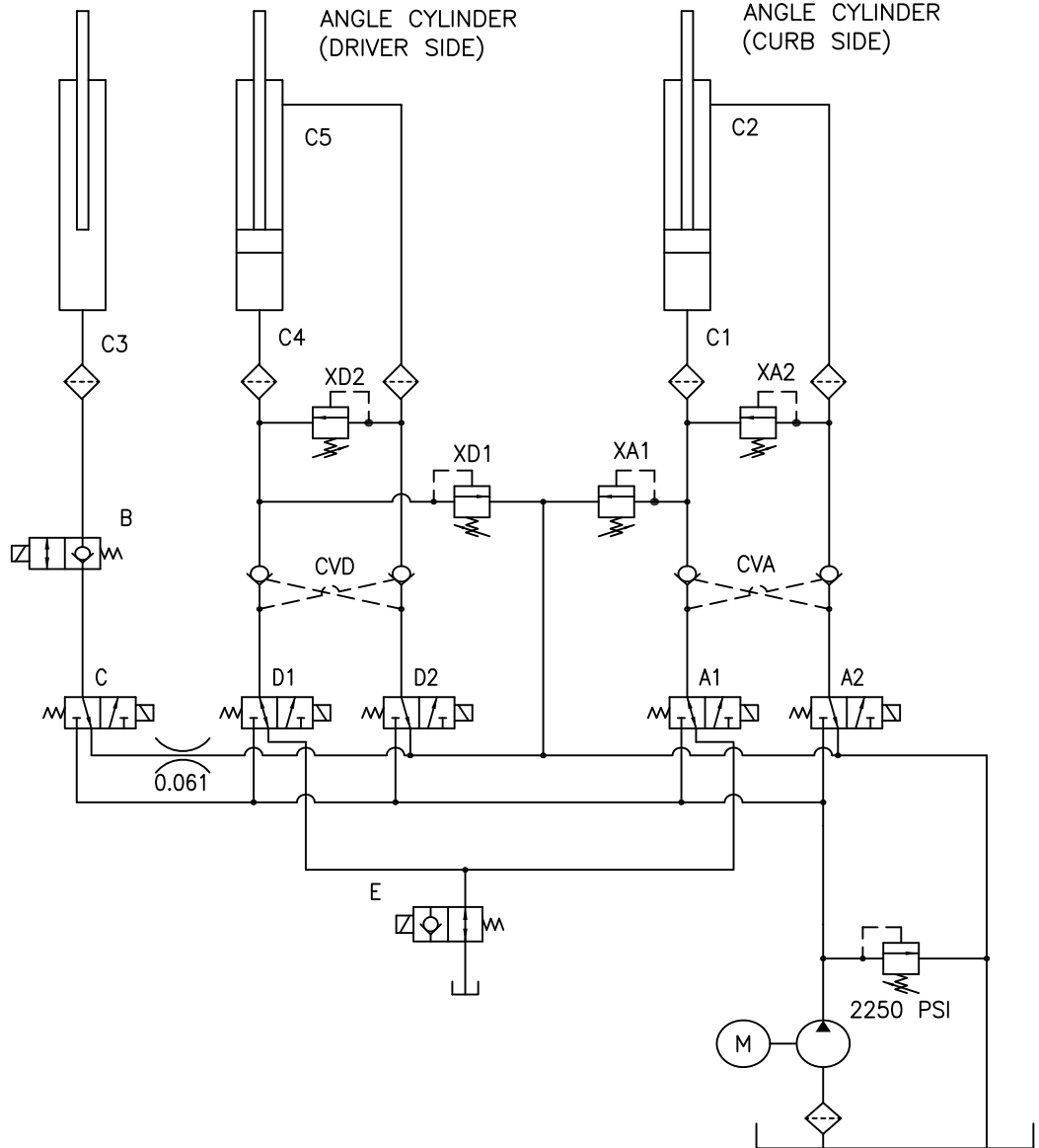

ELEC DEVICE	FUNCTION									
	RAISE	LOWER	ANGLE RIGHT	ANGLE LEFT	VEE	SCOOP	RIGHT RET	RIGHT EXT	LEFT RET	LEFT EXT
MOTOR	ON		ON	ON	ON	ON	ON	ON	ON	ON
D2				ON	ON				ON	
D1						ON				ON
A2			ON		ON		ON			
A1						ON		ON		
C	ON									
B		ON								
E			ON	ON						

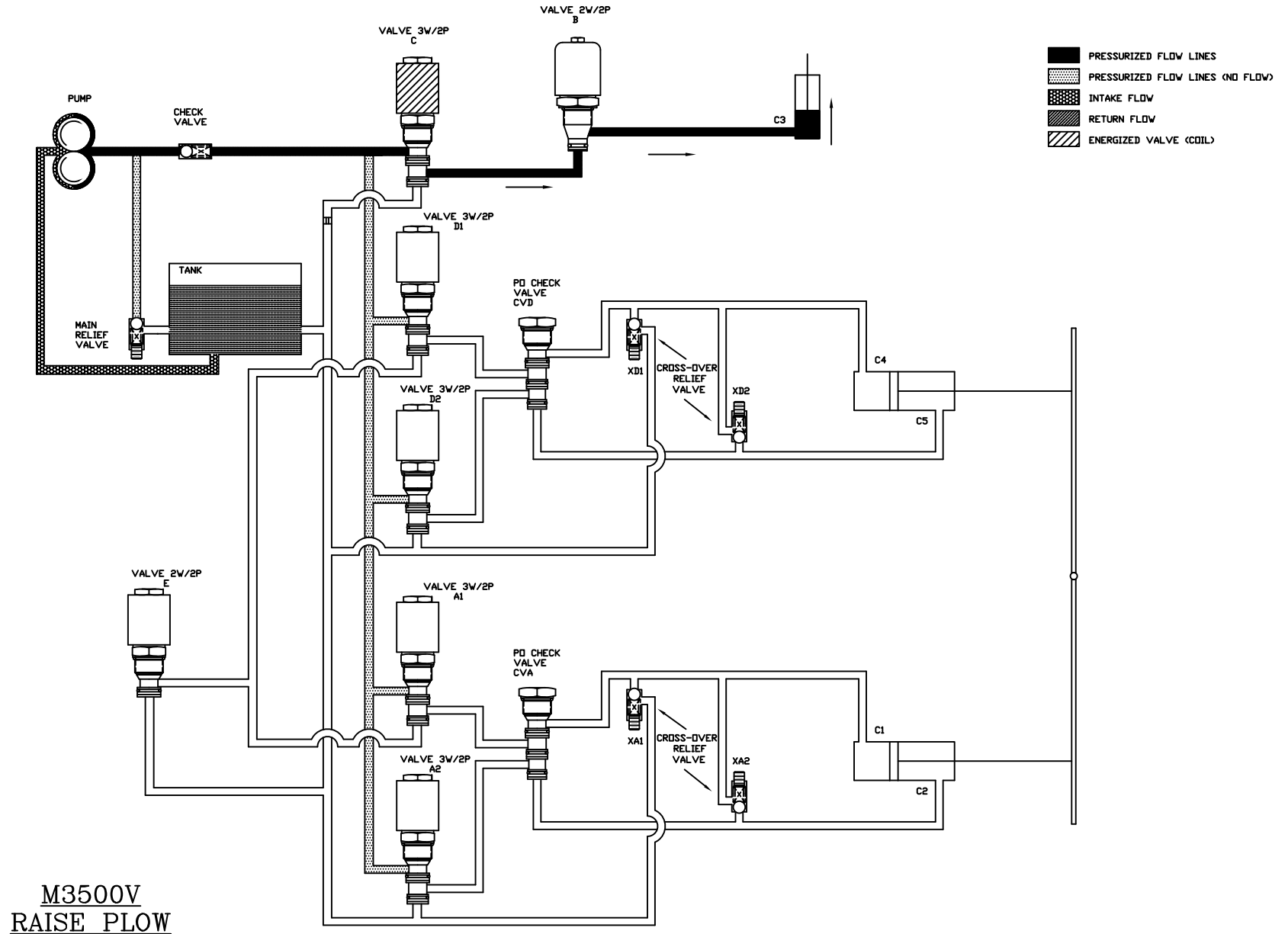

M3500V
RAISE PLOW

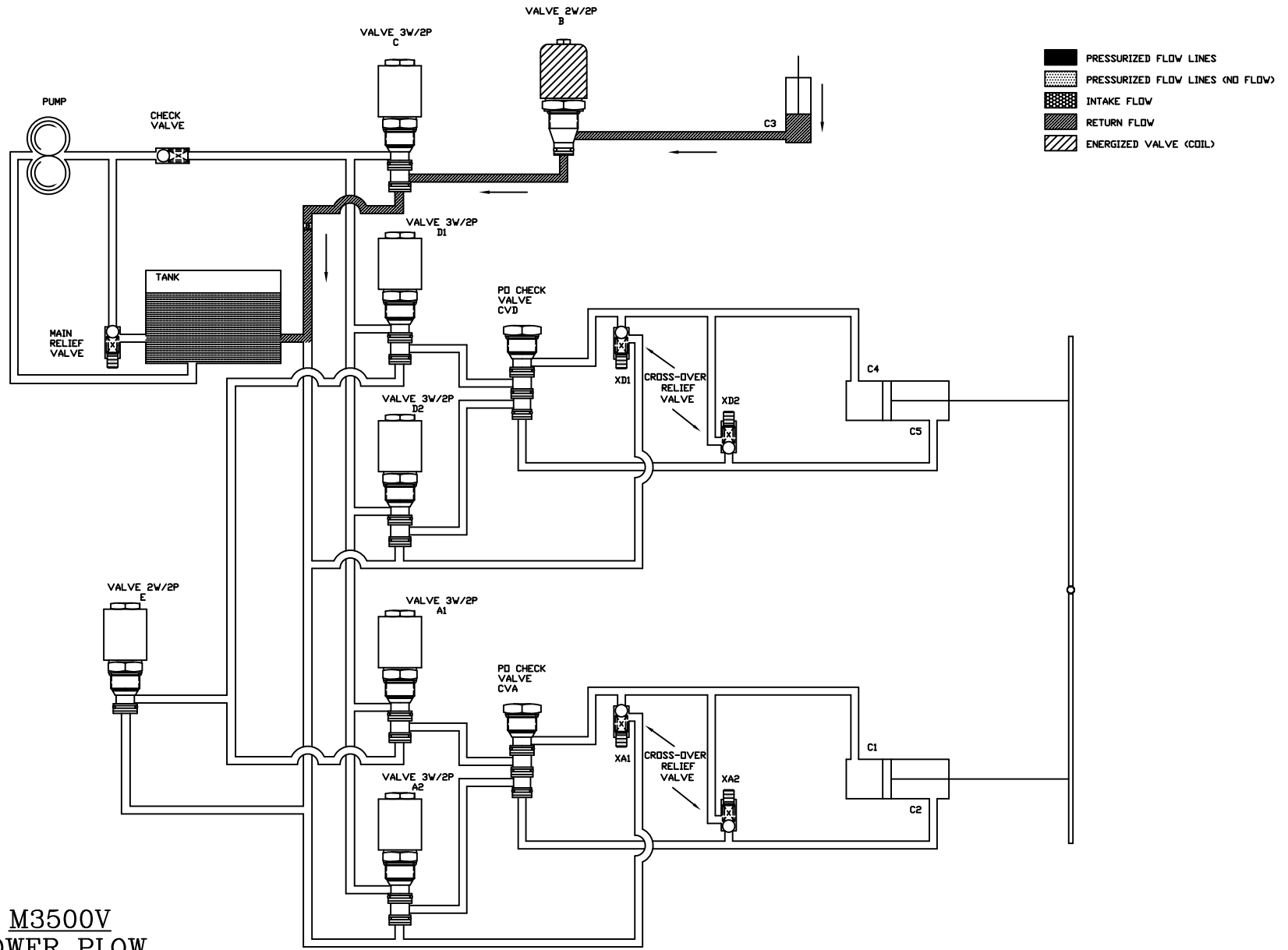

M3500V
LOWER PLOW

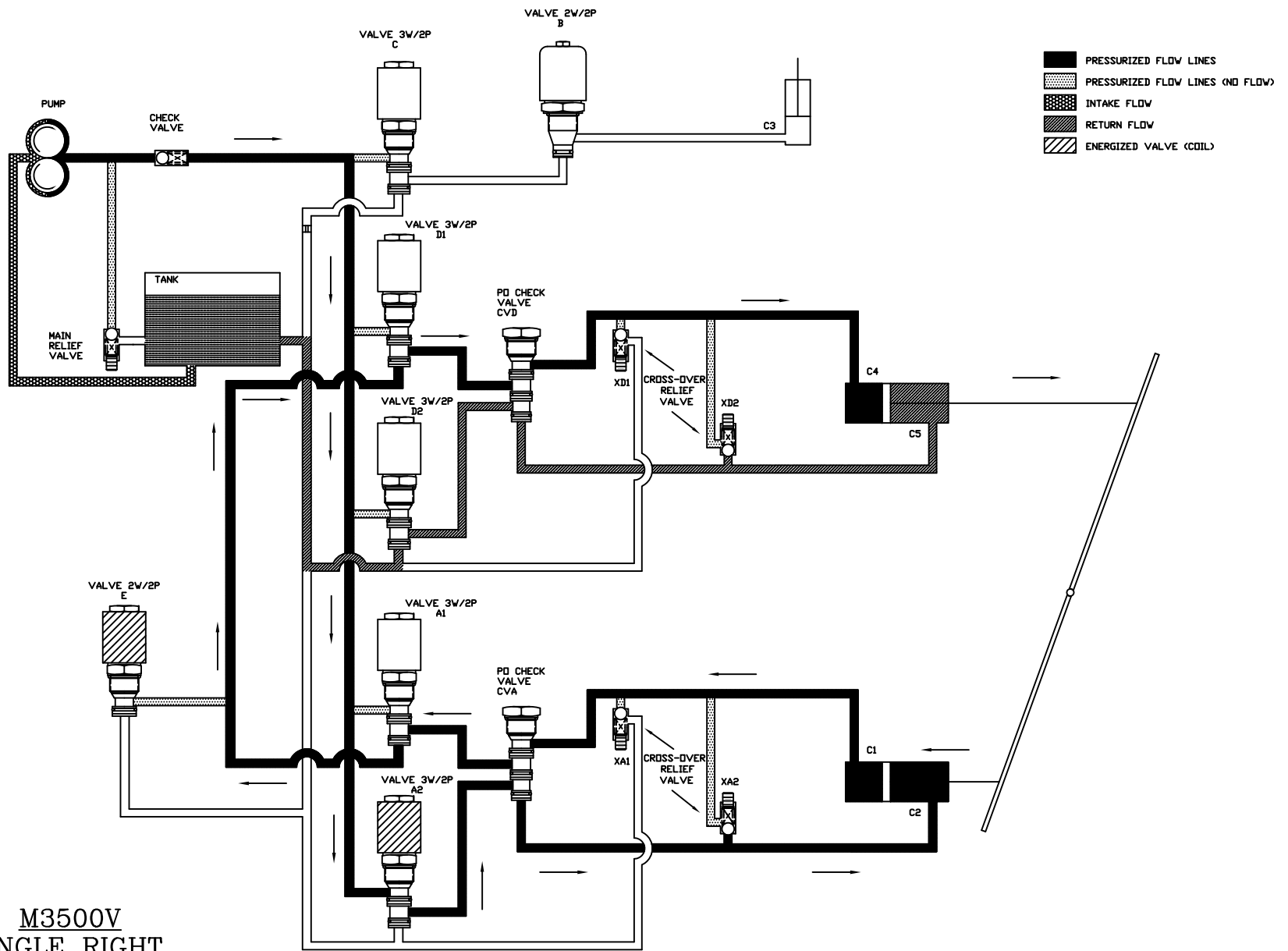

M3500V
ANGLE RIGHT

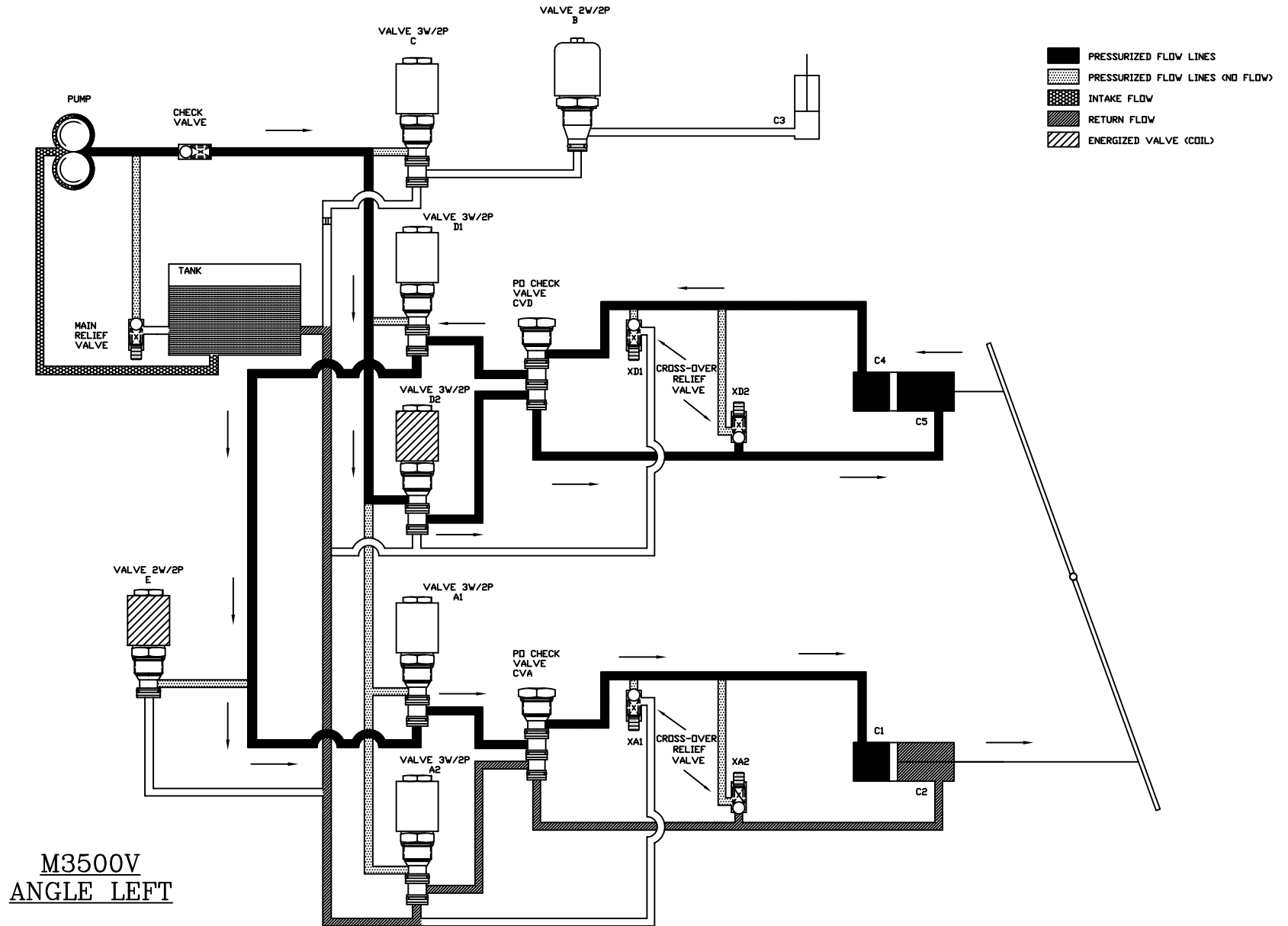

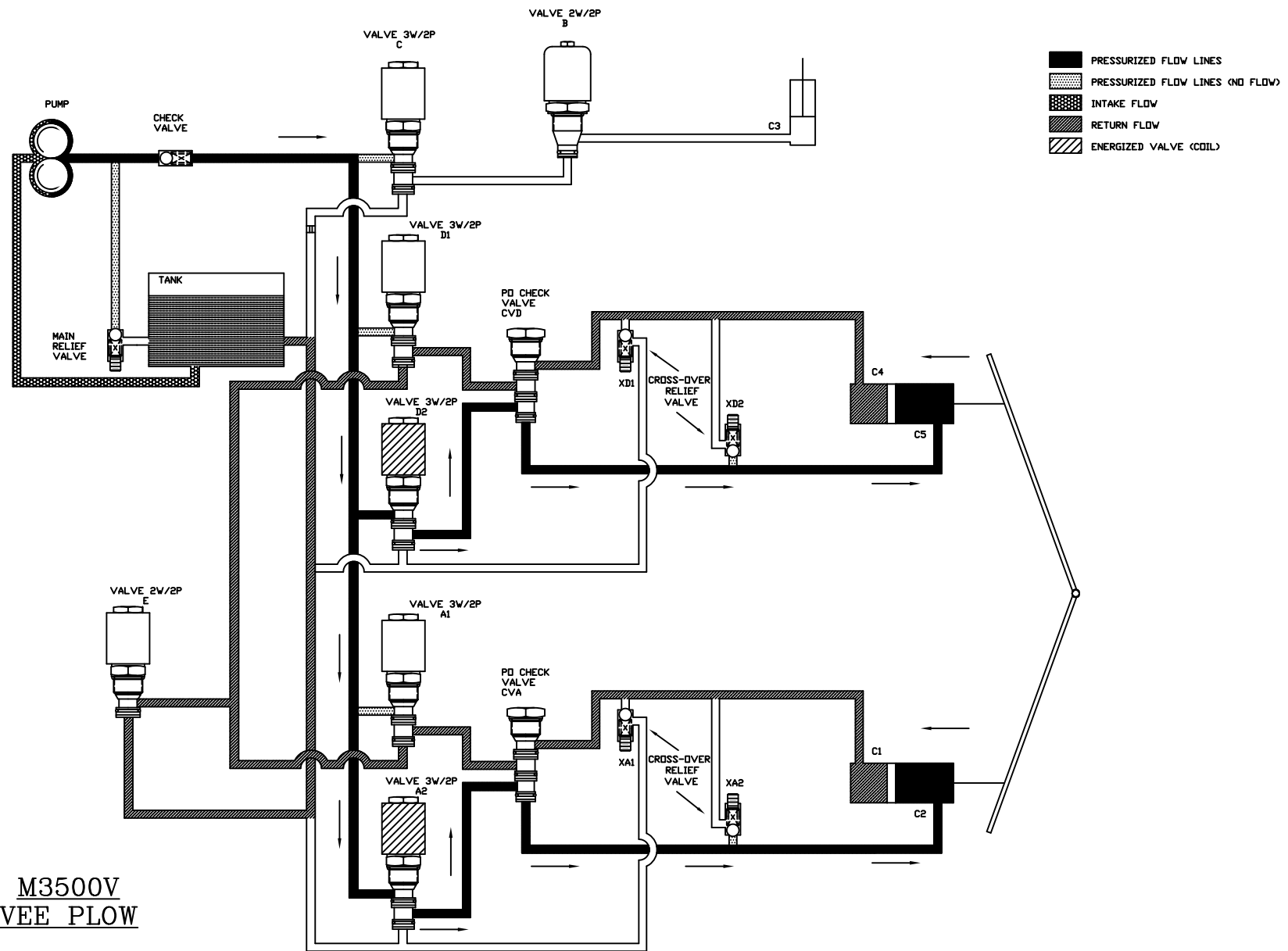

M3500V
VEE PLOW

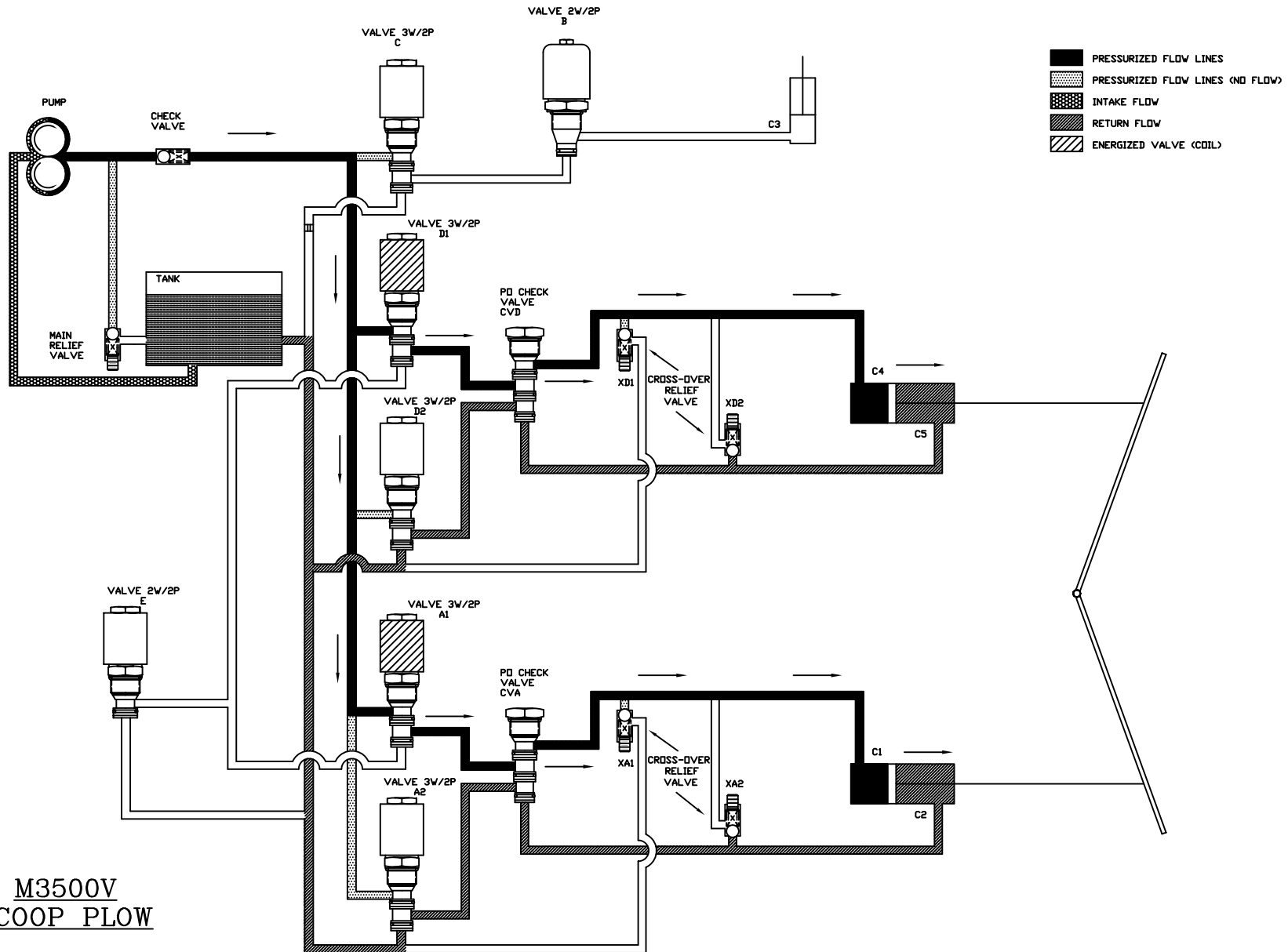

M3500V
SCOOP PLOW

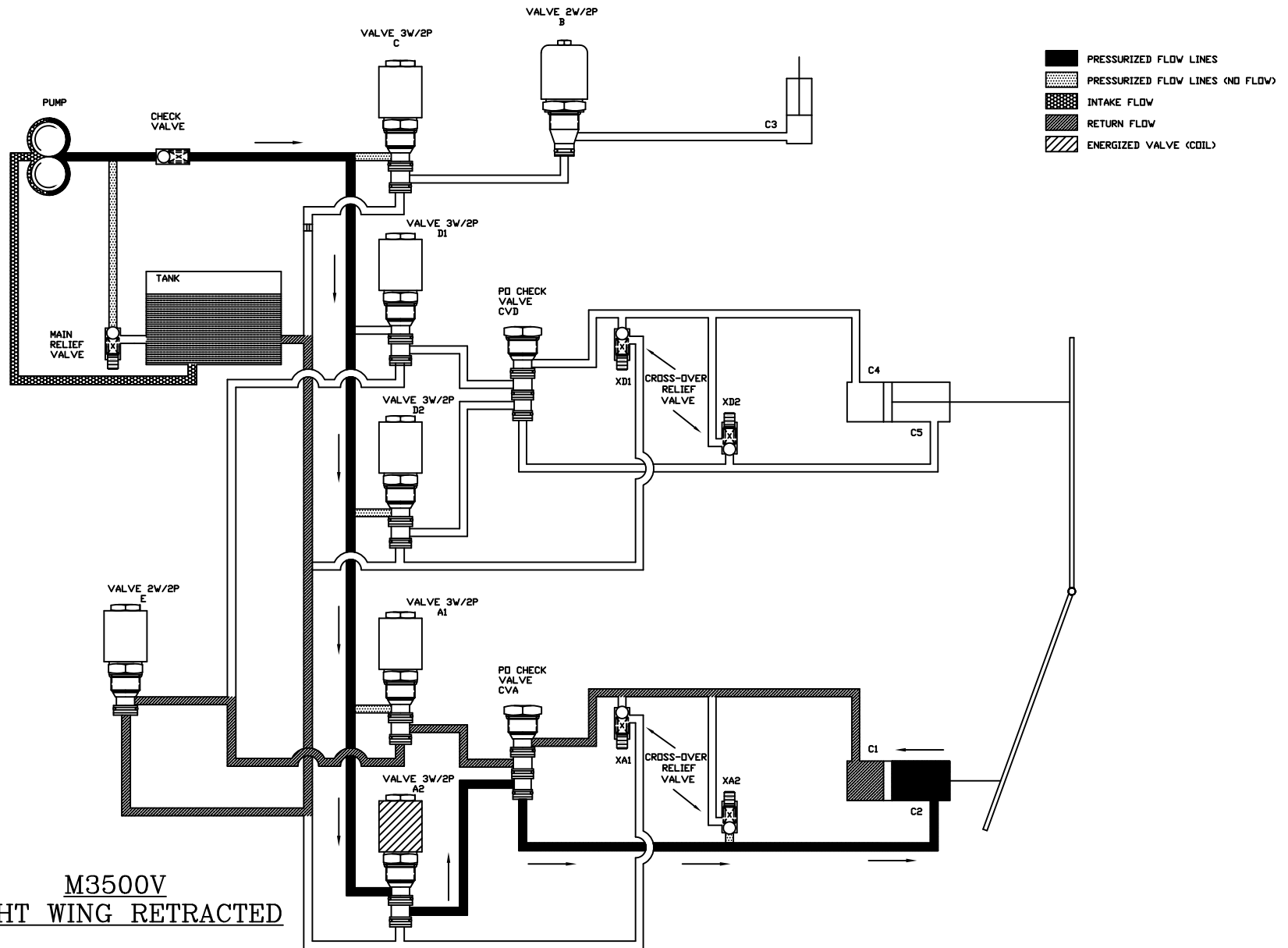

M3500V
RIGHT WING RETRACTED

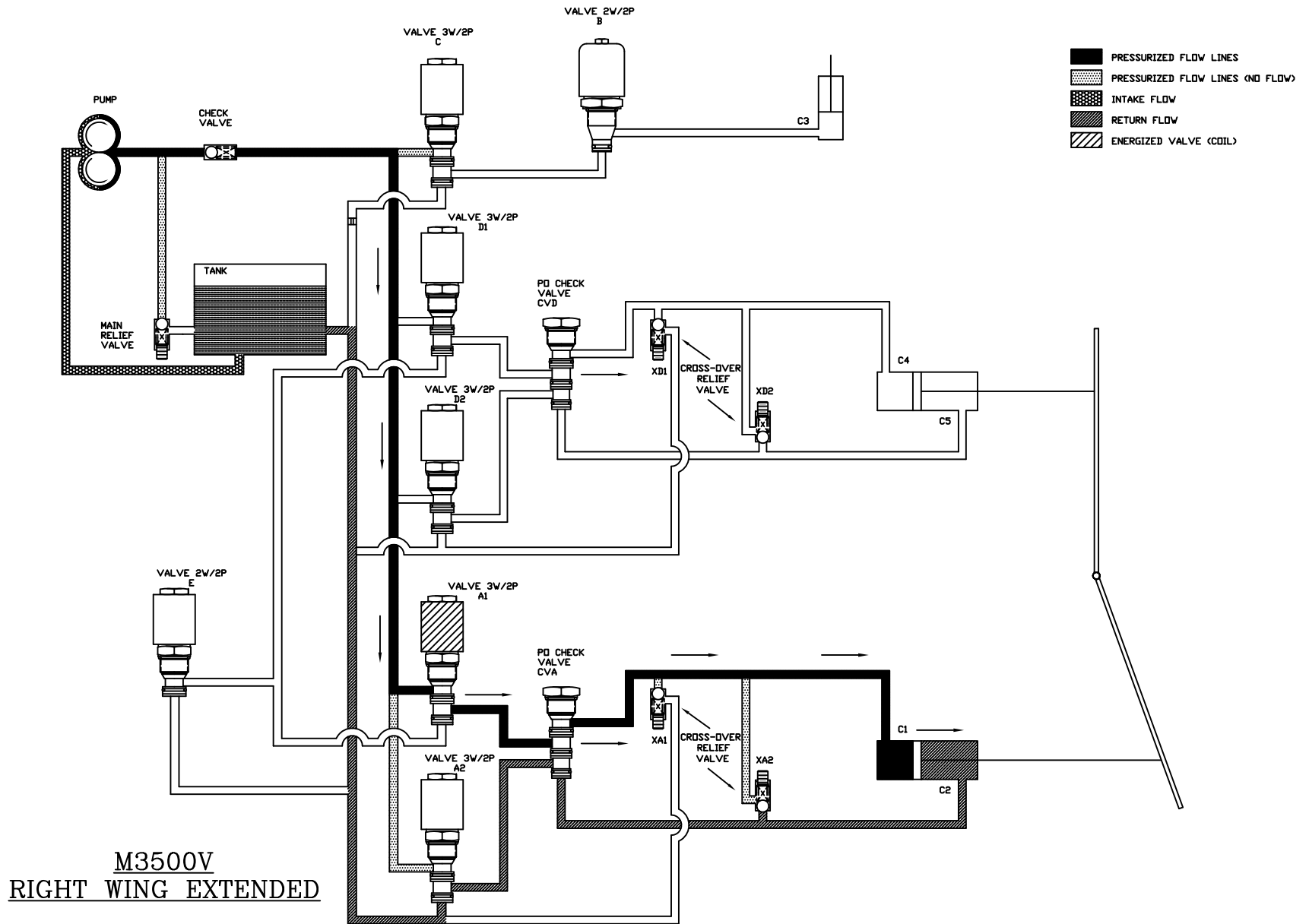

M3500V
RIGHT WING EXTENDED

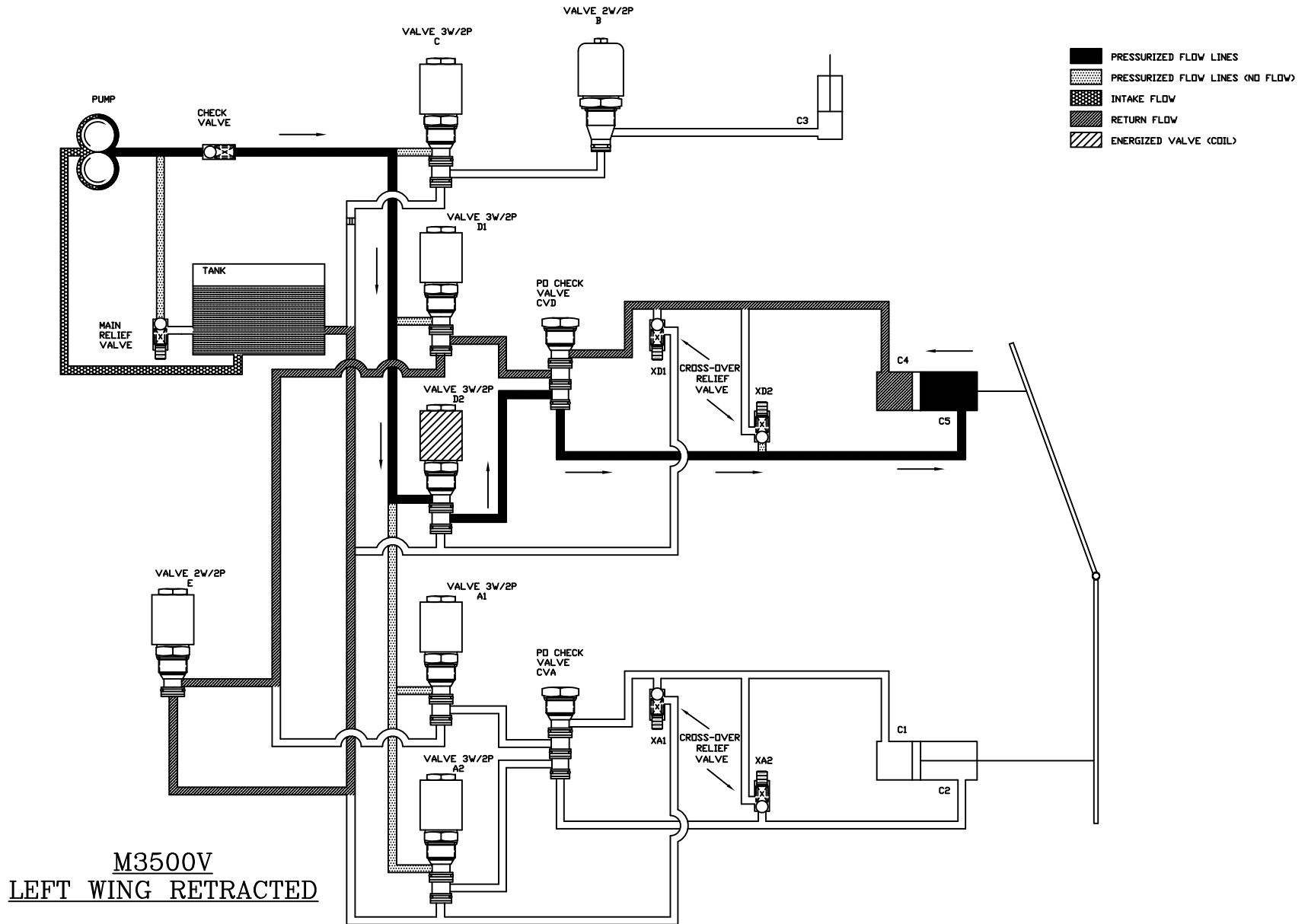

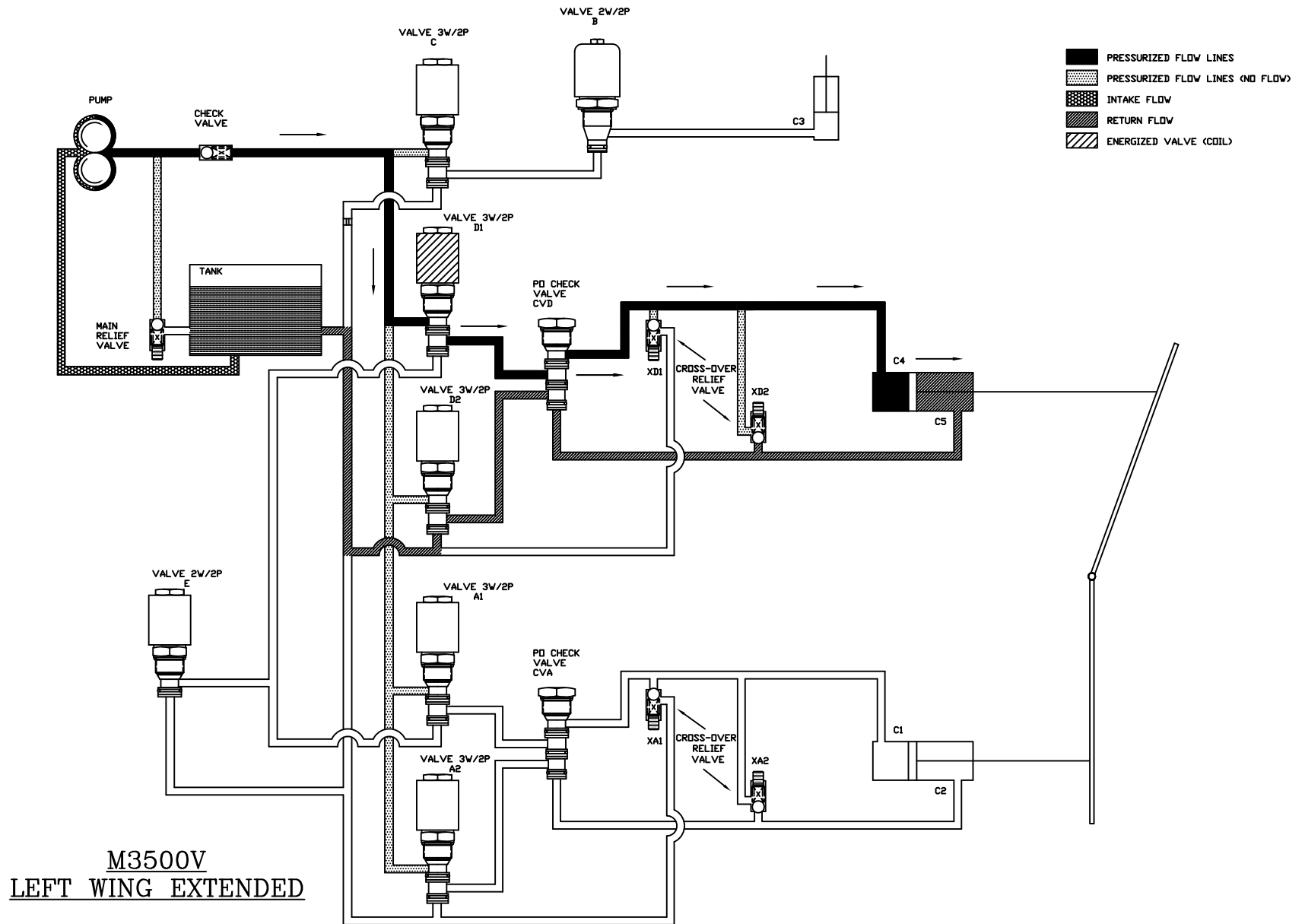

M3500V hydraulic installation instructions

(for electrical installation instructions check one piece harness 53617-M or multiplexing
installation 53618-M)
(it requires light kit 800084 or 800085 or 800086)

M3500V Hose and fitting installation



VIEW 'D-D'

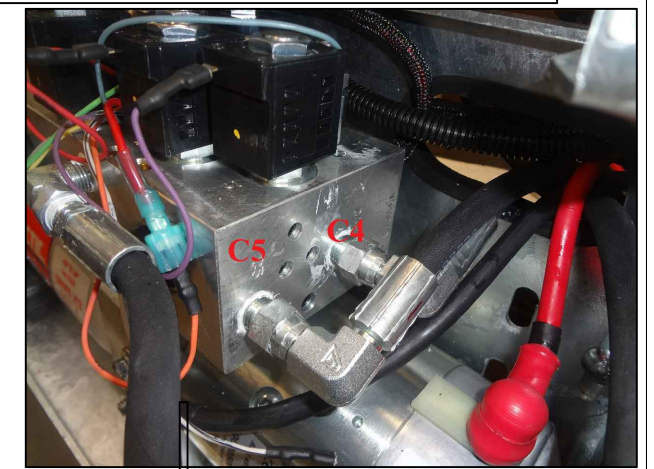

VIEW 'E-E'

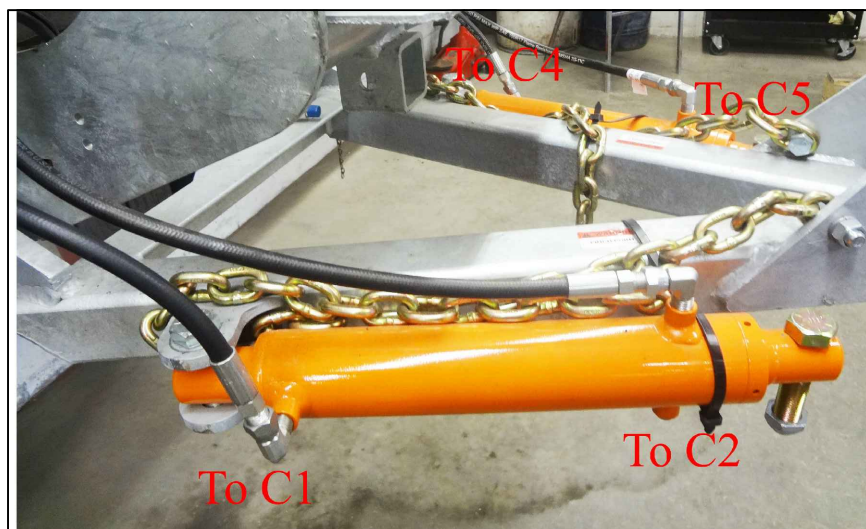
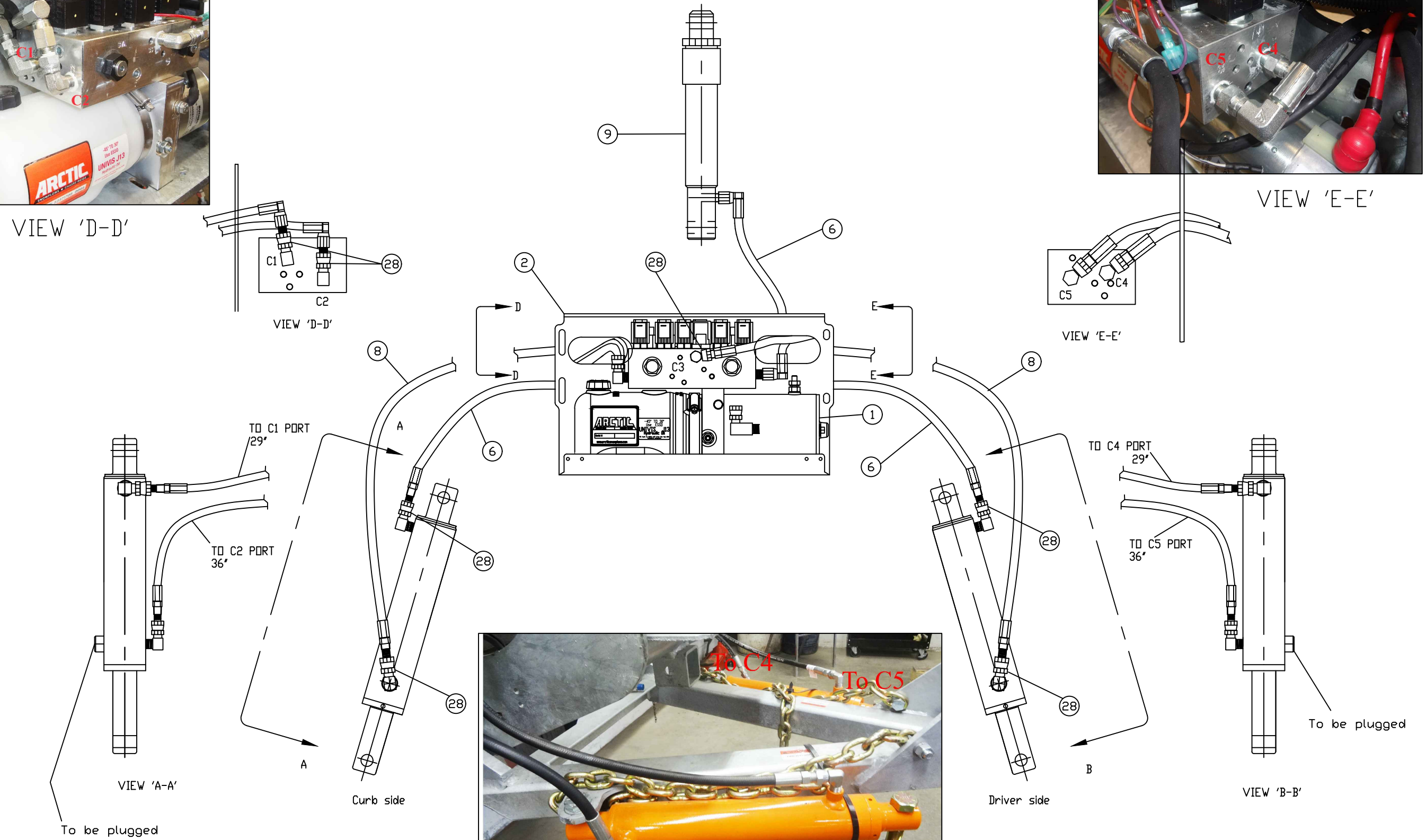

M3500V installation instructions

Warning:

- Top of battery needs to be protected. If positive side of battery is accidentally grounded person could be burnt or wiring system can be damaged, or battery gasses could explode causing injuries.
- Disconnect cable from negative battery terminal before starting installation.
- Always wear eye protection and protective clothing when working around hydraulic systems.
- Remove jewelry and objects that might conduct electricity while working on power units.
- Fluid under pressure can pierce the skin and enter the bloodstream causing death or serious injury.
- Hydraulic hoses and electrical cables (harnesses) must be tied and routed safely to avoid any damage and pinching (away from hot places, sharp objects etc.).

Note: Do not use Teflon tape on hydraulic fittings as it can easily jam valves and plug the filters in the system. **Use of fluid other than J13 will void warranty. Apply dielectric grease to all connections to prevent corrosion.**

[Read also One piece harness installation / Multiplexing installation instructions before proceed with the installation below.](#)

*For electrical installation read:
one piece harness installation 53617-M or multiplexing installation 53618-M / 53618-02-M.*

Hydraulic Installation:

1. Install hoses and fittings as per diagrams and pictures below.
2. Remove vent cap and fill reservoir with UNIVIS J13 (HVI 13) hydraulic oil. Do not use automatic transmission fluid in this system as it may lead to aeration of the oil in very cold weather conditions. Use of fluid other than J13 will void warranty.
3. Manually angle V plow blade in the scoop position. Tighten hose – the fittings on the cylinders closer to the blade. The hose connection on the cylinder side closer to the truck must be loose (to let air out). Press the controller to move blade in V position.. Tighten hose – the fittings on the cylinder side closer to the truck. Fill up the reservoir, so that oil level is 1/2” from the top of the reservoir, and angle the blade in the scoop and V position a few times. Move, operate, the blade up and down, individual wings, left and right and refill it up as necessary.

53621-M V plow hydraulic kit			
	Part#	Description	Quantity
1	M3500010-01B01E	Power Unit	1
2	52870-C-GA	Pump Plate	1
3	53476-B	18" Cable Plug Assembly	1
4	53477-B	90" Ground Cable (Black)	1
5	53478-B	90" Power Cable (Red)	1
6	51904-M	29" Hose Assembly (St-90)	3
7	52429-C	Cover	1
8	51905-M	36" Hose Assembly (St-90)	2
9	CS200-06.00-NRS	2" x 6" Lift Cylinder	1
10	52870-M-BB	Bolt Bag	1
11	51335-22-M	Battery Cable, 22"	1
12	51335-56-M	Battery Cable, 56"	1
13	53608-N	Circuit Breaker 135 AMP	1
52870-M-BB Bolt Bag			
14	52436-N	Grommet 1/4" x 1.3/4" x 2.1/2"	2
15	52700-01-N	Grommet 1/8" x 3" x 3.625"	1
16	HH-00293-006	1/4-20x1 HHCS	3
17	HH-00293-049	3/8-16x1 HHCS	2
18	HH-00971-043	5/16-18x1 Carriage bolt	4
19	HH-00340-017	5/16-18 Nyl. Ins.	4
20	HH-00341-004	3/8 Flatwasher	2
21	HH-00457-004	3/8 Lockwasher	2
22	HH-00294-001	1/4-20 Hex Nut	1
23	HH-00457-006	1/4 Lockwasher	1
24	HH-00293-028	5/16-18x1 HHCS	1
25	HH-00457-007	5/16 Lockwasher	1
26	52427-N	Red Terminal Protector	1
27	53560-A	Dummy Plug (Power&Ground)	1
28	HH-00790-002	90 Deg Swivel Elbow	6
29	490056-01	Dielectric Grease	1
30	HH-00455-007	Screw #8 x 3/4"	4
31	HH-00340-901	1/4" Course Lock Nut	2
32	53541-N	6" Cable Tie	2

Arctic Equipment Manufacturing Corporation reserves the right under its product improvement policy to change construction or design details and furnish equipment when so altered without reference to illustrations or specifications used.

M3500V installation instructions

(prior to 2013)

M3500V installation instructions

Warning:

- Top of battery needs to be protected. If positive side of battery is accidentally grounded person could be burnt or wiring system can be damaged, or battery gasses could explode causing injuries.
- Disconnect cable from negative battery terminal before starting installation.
- Always wear eye protection and protective clothing when working around hydraulic systems.
- Remove jewelry and objects that might conduct electricity while working on power units.
- Fluid under pressure can pierce the skin and enter the bloodstream causing death or serious injury.
- Hydraulic hoses and electrical cables (harnesses) must be tied and routed safely to avoid any damage and pinching (away from hot places, sharp objects etc.).

Note: Do not use Teflon tape on hydraulic fittings as it can easily jam valves and plug the filters in the system.

Apply dielectric grease to all connections to prevent corrosion

Use of fluid other than J13 will void warranty

1. Install colour co-ordinated weather cover (8) on cable and plug assembly (4). Attach red lead to positive motor stud and black lead to negative motor stud. Liberally coat connections with dielectric grease then slide covers over the eyes on the end of the cables.
2. Install power unit (1) and mounting plate (2) with motor toward driver's side of truck (use star washers under bolts to bolt the pump plate to the lift frame - use star washers AND removable grade Loctite to fasten power unit to the pump plate).
3. Route power unit harness through grommet in driver's side of mounting plate and secure using cable clamp (attached to power unit harness) and ¼" x 1" bolt.
4. Mount solenoid (35) to metal surface in engine compartment bending bracket if necessary. Be sure to locate the solenoid so that there is sufficient cable to reach to both the battery and the cable and plug assembly (4) on the power unit.

NOTE: Solenoid must be well grounded in order to function properly.

5. Slide weather cover (10) over power cable (6) and ground cable (5) and route through grille of truck leaving sufficient length to attach to the cable and plug assembly (4). Secure the red power cable (6) to the large terminal on the solenoid and the black ground cable (5) to the negative terminal on the battery.
6. Secure power cable (7) from other large terminal on solenoid to positive terminal on battery.
7. Plug intermediate under hood harness (33) into valve section harness (34) and follow battery cable routing toward firewall. Locate a pass through hole in the firewall near the driver's side of the truck. Route other end of intermediate under hood harness (33) through the hole in firewall and attach to the intermediate in cab harness (32). Intermediate in cab harness must be secured under the dash and it should be attached to control station (Note: White wire must be attached under the dash (ground)).
8. Attach black wire to positive side of solenoid and brown wire to small terminal on top of the solenoid (35).
9. Neatly secure all excess cables and wires using tie straps. Silicone hole in firewall.
Note: Be sure all cables are properly protected from any sharp edges or hot or moving parts!!
10. Install hoses and fittings as shown on installation drawing. Note: All 90 degree swivel elbows (14) will be mounted on power unit, connecting to straight end of hose. Opposite end of hose (90 degree) will plug into cylinders (see diagram).
11. Remove vent cap and fill reservoir with **UNIVIS J13 (HVI 13) hydraulic oil**. Do not use automatic transmission fluid in this system as it may lead to aeration of the oil in very cold weather conditions. **Use of fluid other than J13 will void warranty.**
13. Manually angle one section of the blade to one side before activating the power unit. This can be easily accomplished, as the hose connections are loose at the angling cylinders.
14. Jog the controller (extend and retract cylinder), operate only section of the blade that was manually extended, until no air is seen in the fluid passing through the loose connection. Tighten fittings.
15. Refill power unit. Repeat same steps for second section of the blade.
16. Refill power unit. Jog the controller to lift blade until no air is seen in the fluid passing through the loose connection. Tighten fittings.

17. Refill power unit so that oil level is 3/4" from the top of the reservoir. Clean up any spilled oil and check all functions several times making sure there is not excessive foaming in the reservoir. Compress the lift cylinder and double check the oil level. Check for leaks at all fittings.
18. Install power unit cover (13).

Power Unit Kit 52871-M-GA V plow Galvanized			
Item	Part #	Description	Quantity
1	M3500010-01B01E	Power Unit V plow	1
2	52870-M-GA	Mounting plate ass'y (includes pump plate, pump plate cover, bolts etc.) Galvanized	1
4	53476-B	18" Cable Plug Assembly	1
5	53478-B	Power Cable 90"	1
6	53477-B	Ground Cable 90"	1
7	51335-22-M	22" Battery Cable	1
8	52427-N	Red Terminal Protector	1
*10	53560-A	Dummy Plug (power and ground)	1
*11	52805-N	Dummy Plug (V plow)	1
11a	52805-01-N	Male housing dummy plug	1
12	51904-M	29" Hose	3
*13	52429-C	Power Unit Cover	1
14	HH-00790-002	90 deg Swivel Elbow	5
15	51905-M	36" Hose	2
18	CS200-06.00-NRS	2 x 6 Lift Cylinder	1
19	52436-N	Grommet 1/4"x1.3/4X2.1/2	3
21	HH-00293-006	1/4-20x1 Hex Head Cap Screw	1
22	HH-00293-049	3/8-16x1 Hex Head Cap Screw	2
24	53146-N	3/8" Star Lockwasher	10

Power Unit Kit 52871-M-GA V plow Galvanized			
Item	Part #	Description	Quantity
25	HH-00972-029	5/16-24x1.1/4 Hex Head Cap Screw	4
26	HH-00460-005	5/16-24 Hex Nut	5
27	53147-N	5/16" Star Lockwasher	2
28	HH-00294-001	1/4-20 Hex Nut	1
29	HH-00457-006	1/4 Lockwasher	1
30	HH-00972-028	5/16-24x1 Hex Head Cap Screw	1
31	53218-N	Plastic Drain Hole Plug	1
32	52802-B	Incab Intermediate Harness 7"	1
33	52803-B	Underhood Intermediate Harness 97"	1
34	52804-B	Valve Section Harness 26"	1
35	FP17757	Solenoid	1
36**	52873-NRS	Cylinder, 2" x 9"	2
37***	52807-01-M	Joystick Ass'y (incl. joystick and bracket)	1
	53326-M	Handheld controller	1

*Items not shown on drawing

**52873-N is part of power angling kit.

*** Item 37 is not part of this kit (it is sold separately).

Arctic Equipment Manufacturing Corporation reserves the right under its product improvement policy to change construction or design details and furnish equipment when so altered without reference to illustrations or specifications used.

M3500V POWER UNIT WIRING INSTALLATION PRIOR 2013

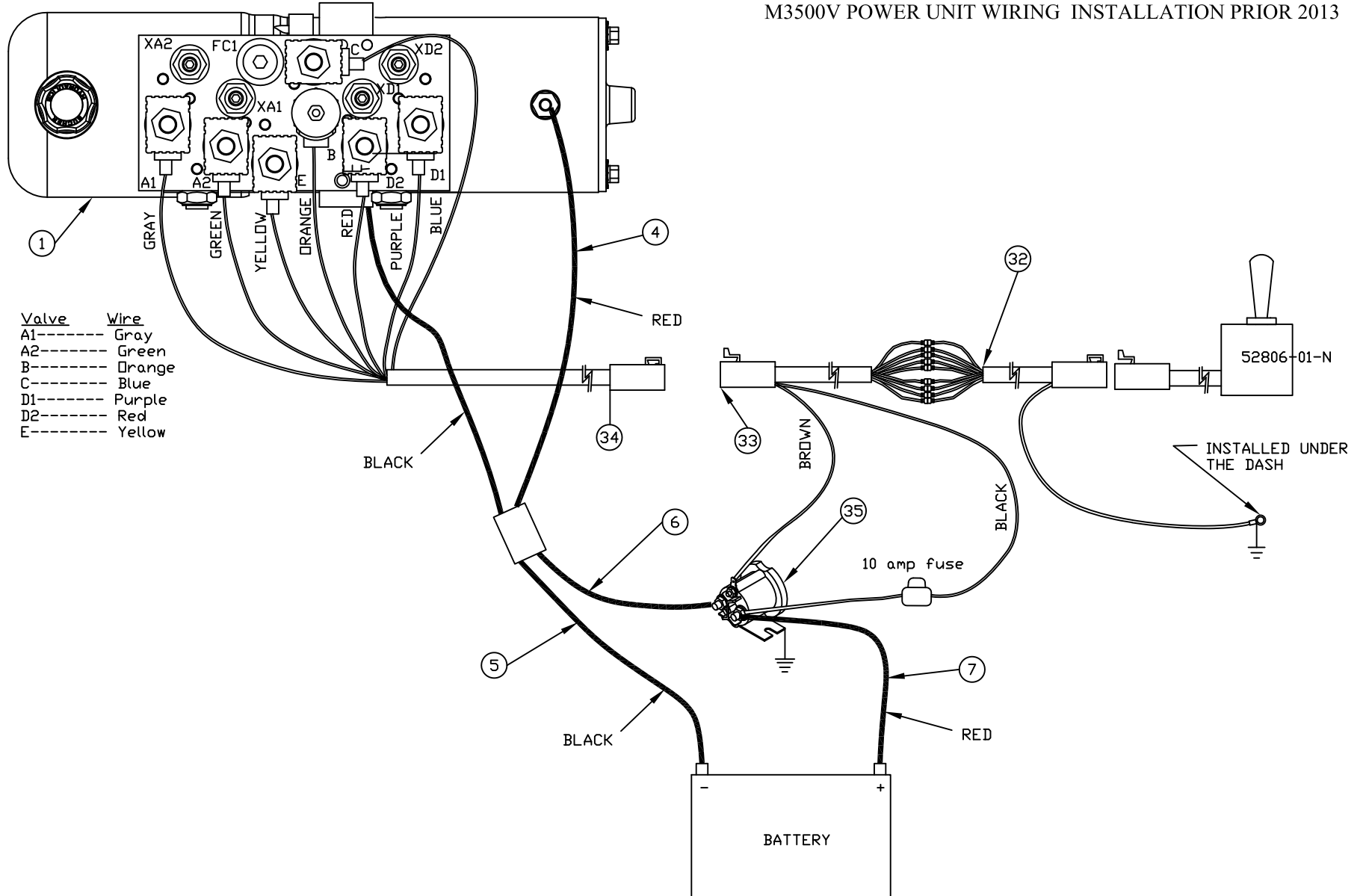

52871-M Power Unit Kit M3500V Hose and fitting installation prior 2013

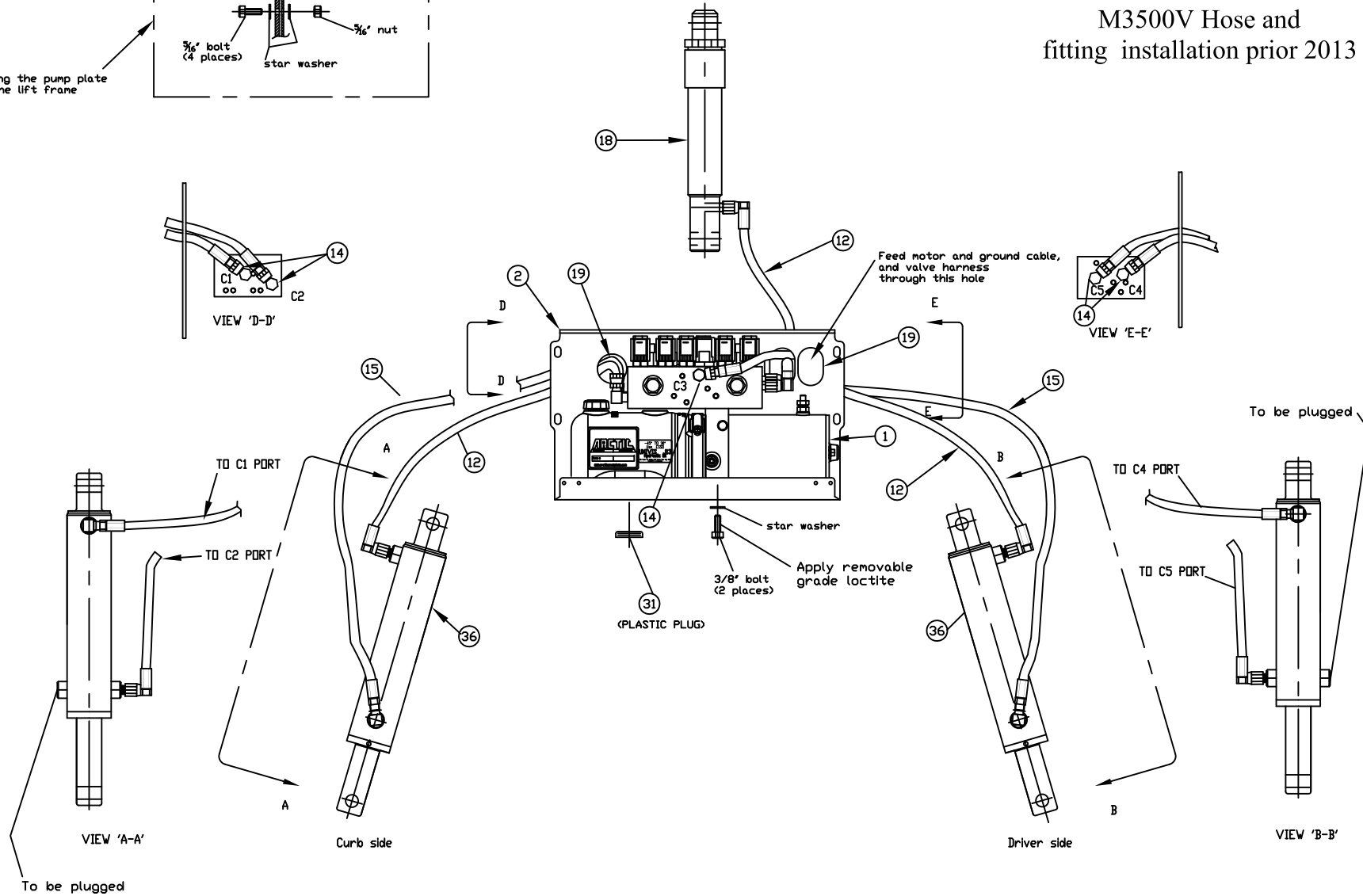
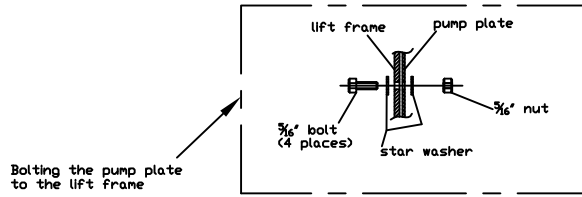

M3500V
Parts List
(prior to 2012)



POWER UNIT M3500V prior to 2012

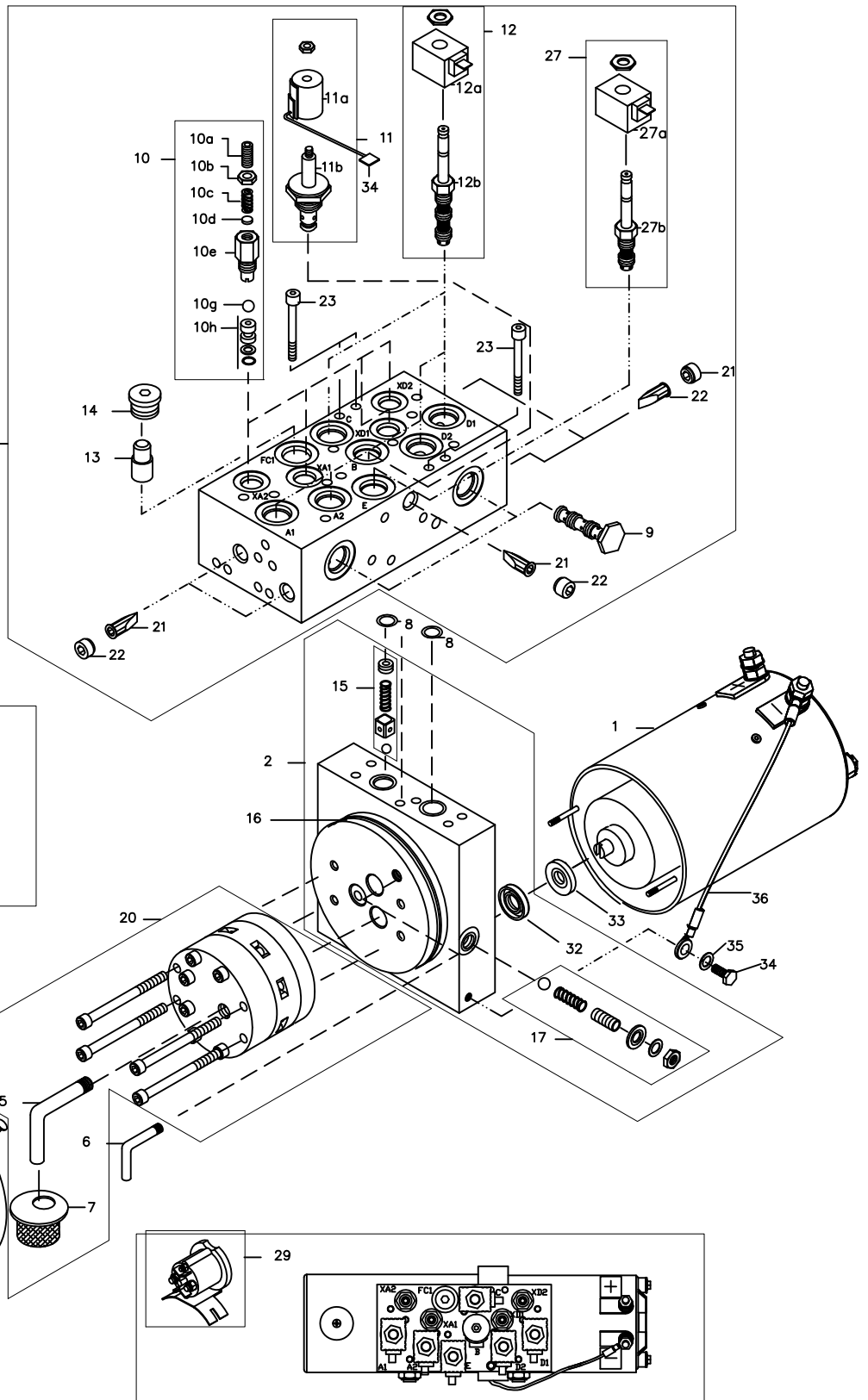
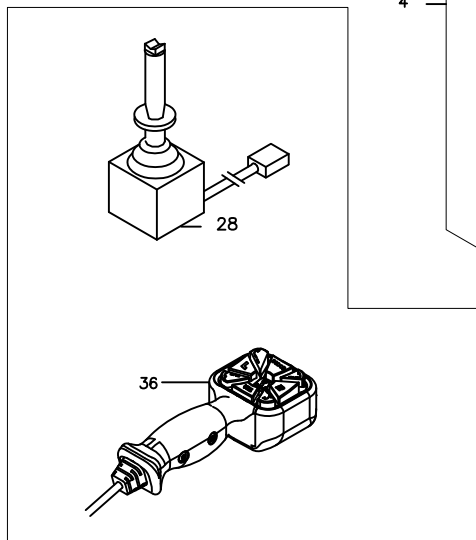

M3500V Parts List (prior 2012)				
Rev		Qty	Part #	Description
R01	1	1	FP18442	Motor,ISKRA, 12 VDC with ground stud
	1a	1	FP8714	Brush Kit for ISKRA Motor (FP184420
	1b	1	52589-M	Brush Kit for Prestolite Motor (FP8034)
	2	1	FP12345-1	Pump base assembly M3593
	2a	1	FP7985	Needle Bearing (Pump Shaft to Pump Base)
	3	1	FP6661-2	Reservoir, 4-1/2" DIA x 8" length
	4	1	FPN0854-SA	Manifold assembly (incl. all valves)
	4a	1	FPN0854-1	Manifold only
	5	1	FP1209	Suction tube
	6	1	FP13058	Return tube
	7	1	FP1134	Suction filter
	8	2	FP0118	O-ring, 5/8 x 3/4 x 1/16 -016
	9	2	FP7346	Valve, PO check valve (CVA, CVD)
	10	4	FP13023	X over valve assembly (XA1, XA2, XD1, XD2)
	10a	1	FP7899	Screw
	10b	1	FP0386	Sealing nut
	10c	1	FP0147	Spring
	10d	1	FP1288	Plate
	10e	1	FP0379	Housing
	10g	1	FP0012	Ball
	10h	1	FP0378	Seat
R04	11	1	FP0490-D	Valve, #8, 2W / 2P, NC poppet (B)
R04	11a	1	FP10861-D	Coil #8, 2W / 2P 12V
R04	11b	1	FP10907-D	Valve cartridge, #8, NC poppet
R04	12	5	FP7249-D	Valve, #8, 3W / 2P, c/w spade terminal (A1, D1, A2, D2, C)
R04	12a	1	FP18835-D	Coil, 12 VDC, #8, with spade terminal
R04	12b	1	FP0679-D	Valve cartridge, #8 spool, 3W / 2P
	13	1	FP17232.0	Pressure compensated flow control
	14	1	FP3274	Plug, SAE #8
	15	1	FP7526	Check valve kit
	16	1	FP2352	O-ring, 3-5/8" x 3-7/8 x 1/8, -239
	17	1	FP7527	Relief valve,(flat washer FPN0575/seal washerFP3874
	18	1	FPN0572	Breather
	19	6	FP7703	Screw, 10-24 x 3/8" self tapping
	20	1	FP12171-250-SA	Pump assembly kit
	21	5	FP1316	Filter, screen
	22	5	FP7624	Screw, filter retainer
	23	4	FPN0748	Screw, SHCS, 1/4-20 x 3"
	24	1	52804-B	Harness, valve section

M3500V Parts List (prior 2012)				
Rev		Qty	Part #	Description
	25	1	52803-B	Underhood intermediate harness
	26	1	52802-B	Incab intermediate harness
R04	27	1	FPN0862-SA-D	Valve assembly #8, NO poppet, 12 VDC (E)
R04	27a	1	FP18835-D	Coil #8 with spade terminal
R04	27b	1	FP7276-D	Valve cartridge #8, NO poppet
	28	1	52806-N	Control station, joystick
R02	29	1	FP17757	Solenoid, switch
R03	30	1	53220-N	Plug, SAE O ring 7/16"
	32	1	FP2159	Pump shaft seal
	33	1	FP2318	Motor bearing
	34	1	761656	Spade connector, male 1/4" tab, insulated, 20 g wire
	35	1	53329-A	Motor to Base Ground Wire
	36	1	53326-M	Handheld Controller (V Blade only)

Items Not Shown on Drawing

- R01: FP18442 replaces FP8034
- R02: FP17757 replaces FP7518
- R03: Added drain plug
- R04: FP0490-D replaces FP0490
 - FP10861-D replaces FP0496 *note: if Deltrol coil FP0496 is replaced with Deltrol coil FP10861-D Deltrol cartridge FP0307 must also be changed to Deltrol cartridge FP10907-D.
 - FP10907-D replaces FP0307 *note: if Deltrol cartridge FP0307 is replaced with Deltrol cartridge FP10907-D, Deltrol coil FP0496 must also be changed to Deltrol coil FP10861-D.
 - FP7249-D replaces FP7249
 - FP18835-D replaces FP10977
 - FP0679-D replaces FP0679 *note: if Parker cartridge FP0679 is replaced with FP0679-D, Parker coil FP10977 must also be changed to Deltrol FP18835-D.
 - FP7276-D replaces FPN0565 *note: If Parker cartridge FPN0565 is replaced with Deltrol cartridge FP7276-D Parker valve FP10977 must also be changed to Deltrol coil FP18835-D.
 - FPN0862-SA-D Replaces FPN0862-SA



The pump part # FP12171-250-SA is used prior to 2012, and FP12171-380-SA 2012+.

Instructions for Installing Modular Pump on Existing Unit

1. Remove pump from reservoir by loosening the (6) screws or loosening the band clamp. Note the orientation of the suction screen and tube assembly on the old pump.
2. Loosen (10) pump screws in old pump.
3. Pull old pump off after loosening the (10) screws.
4. **IMPORTANT:** There are two shaft holes in the base, one goes all the way through (drive shaft) and one does not (idler shaft). Remove all loose needle bearings from the idler shaft hole and throw them away, as they are not needed with the new pump. You will need to reinstall the needles in the drive shaft hole. There are twenty-four (24) needles in each bearing. Coat the needle bearings with grease and place them back in the bearing housings in the drive shaft hole that goes all the way through. If the bearings are "caged" do nothing with them.
5. Remove (2) dowel pins from the pump base.
6. Wipe surface of the base clean, removing old oil, dirt, etc.
7. Replace 00120 O-ring provided in pump kit. **(See Figure #1)**
8. **IMPORTANT:** Place a small amount of grease on the tang of the drive shaft. This will help the tang slide past the shaft seal in the pump base without damaging it. Carefully slide the pump into place.
9. Align (4) through holes with (4) empty screw holes in the pump. **(See Figure #2)**
10. Drop the (4) screws provided in the pump kit into the holes. The screws should be started by hand – no air tools.
11. Torque (4) provided screws to between 140 and 160 inch pounds. **(See Figure #3)**
IMPORTANT: Do not over tighten! Do not tighten any other screws in the pump other than the (4) provided loose in the kit.
12. If you removed the motor, turn the drive shaft with a pair of pliers to ensure it turns freely after you have tightened the screws.
13. Remove the suction tube and screen assembly from the old pump's suction plate and install it in the new suction plate.
14. Slide the pump assembly back into the reservoir collar, making sure that the tank O-ring is properly installed. A pinched or deformed seal may result in leaking. Make sure that the suction tube assembly is pointing to the bottom of the reservoir. Align the reservoir screw holes with the screw holes in the base while sliding them together. You may need to tap on the base with a rubber mallet to get it into the reservoir collar.
15. Replace (6) tank screws and tighten. If you have a plastic reservoir, tighten the band clamp.

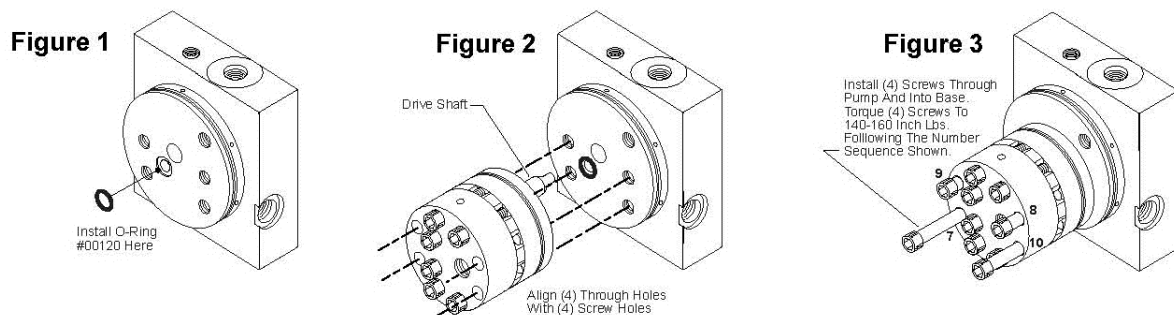

Arctic Equipment Manufacturing Corporation reserves the right under its product improvement policy to change construction or design details and furnish equipment when so altered without reference to illustrations or specifications used.

M3500V Parts List

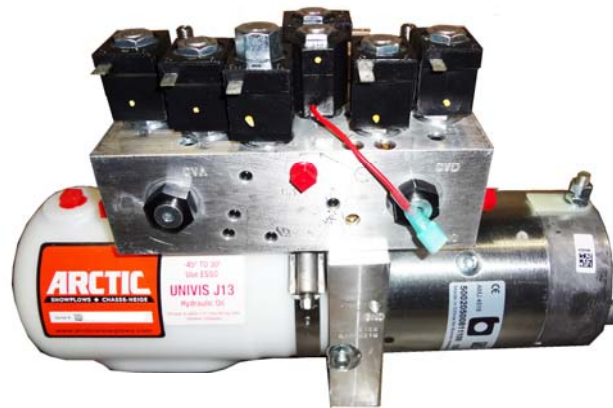

POWER UNIT M3500V
2012+

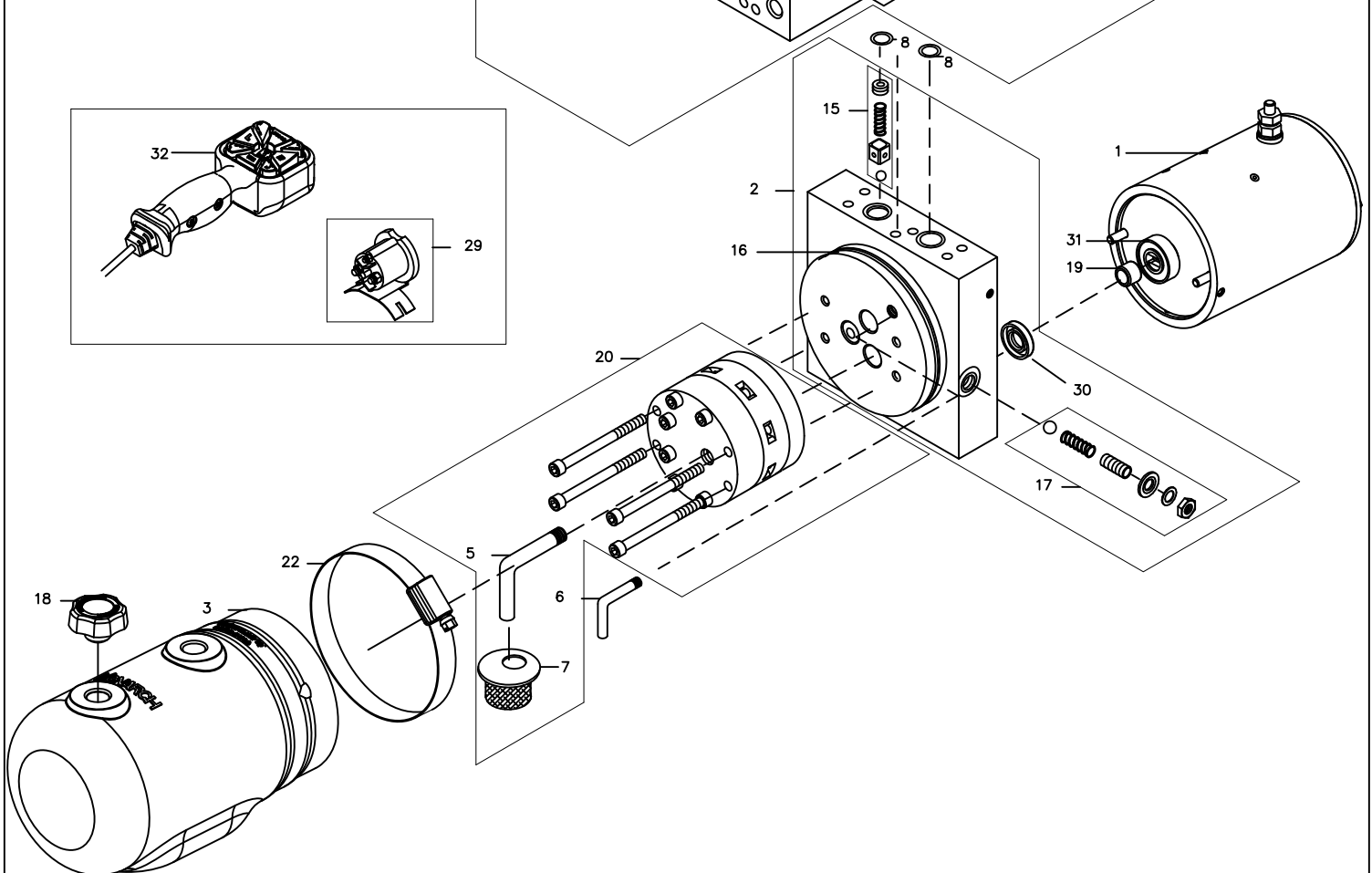
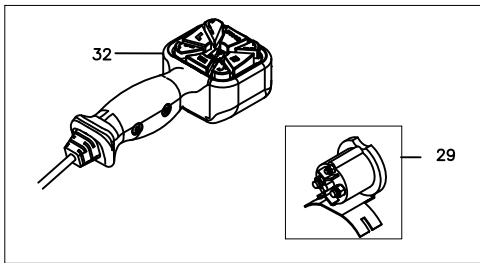
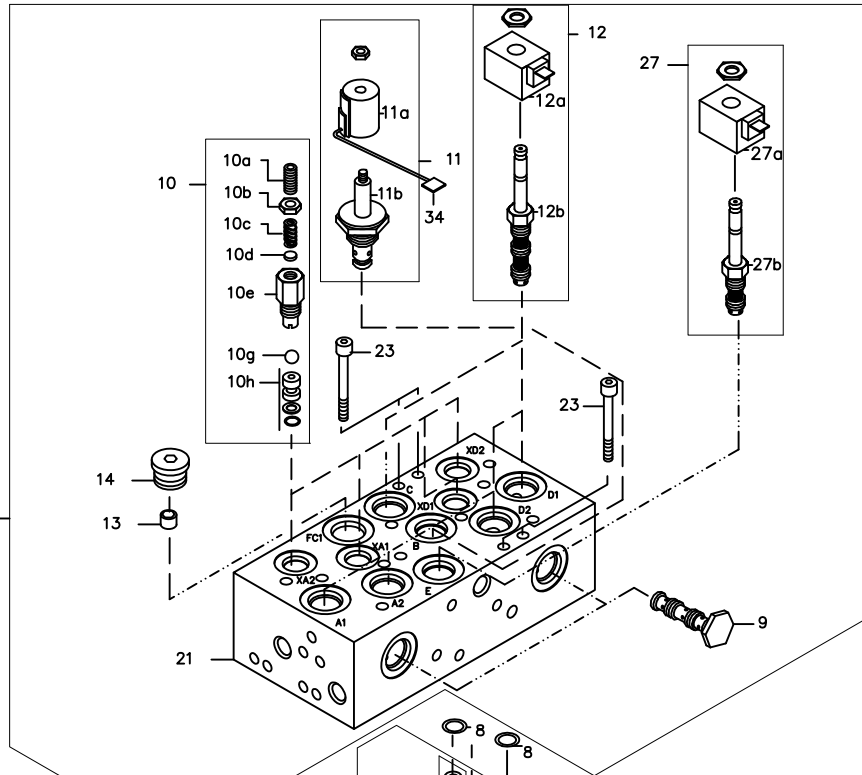
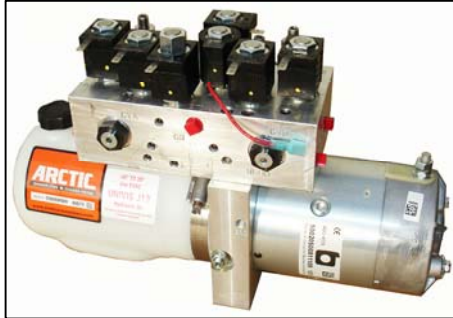

M3500V Power unit (2012+)			
	Part #	Description	Qty
1	FP8111-I	Motor	1
2	FP18405	Pump base assembly	1
3	FP6102	Reservoir	1
4	FPN0854-SA	Manifold assembly (incl. all valves)	1
4a	FPN0854-1	Manifold only	
5	FP1209	Suction tube	1
6	FP13058	Return tube	1
7	FP1134	Suction filter	1
8	FP0118	O-ring, 5/8 x 3/4 x 1/16 -016	2
9	FP7346	Valve, PO check valve (CVA, CVD)	2
10	FP13023	X over valve assembly (XA1, XA2, XD1, XD2)	4
10a	FP7899	Screw	1
10b	FP0386	Sealing nut	1
10c	FP0147	Spring	1
10d	FP1288	Plate	1
10e	FP0379	Housing	1
10g	FP0012	Ball	1
10h	FP0378	Seat	1
11	FP0490-D	Valve, #8, 2W / 2P, NC poppet (B)	1
11a	FP10861-D	Coil #8, 2W / 2P 12V	1
11b	FP10907-D	Valve cartridge, #8, NC poppet	1
12	FP7249-D	Valve, #8, 3W/2P, spade terminal (A1, D1, A2, D2, C)	5
12a	FP18835-D	Coil, 12 VDC, #8, with spade terminal	1
12b	FP0679-D	Valve cartridge, #8 spool, 3W / 2P	1
13	FP2361	Orifice	1
14	53220-N	Plug, SAE #4 (7/16")	1
15	FP7526	Check valve kit	1
16	FP2352	O-ring, 3 3/4 x 4 x 1/8, -240	1
17	FP7527	Relief valve,(flat washer FPN0575/seal washer FP3874)	1
18	FPN0571	Breather	1
19	FP7985	Needle Bearing	1
20	FP12171-380-SA	Pump assembly kit	1
21	FP18410	Manifold only	1
22	FP7900	Clamp, (clamp up to 80inlb)	1
23	FP7752	Screw, SHCS, 1/4 x 2 3/4"	4
24	53469-B	Harness, valve section (one piece harness)	1
25	53470-B	Underhood intermediate harness (one piece harness)	1
26	53473-B	Controller harness (one piece harness)	1
27	FPN0862-SA-D	Valve assembly #8, NO poppet, 12 VDC (E)	1
27a	FP18835-D	Coil #8 with spade terminal	1
27b	FP7276-D	Valve cartridge #8, NO poppet	1
28	53608-N	Circuit Breaker 135 AMP	1

M3500V Power unit (2012+)			
	Part #	Description	Qty
29	FP17757	Solenoid, switch	1
30	FP2159	Pump shaft seal	1
31	FP2318	Motor bearing	1
32	53326-MODE-M	Handheld Controller	1



The pump part # FP12171-250-SA is used prior to 2012, and FP12171-380-SA 2012+.

Instructions for Installing Modular Pump on Existing Unit

1. Remove pump from reservoir by loosening the (6) screws or loosening the band clamp. Note the orientation of the suction screen and tube assembly on the old pump.
2. Loosen (10) pump screws in old pump.
3. Pull old pump off after loosening the (10) screws.
4. **IMPORTANT:** There are two shaft holes in the base, one goes all the way through (drive shaft) and one does not (idler shaft). Remove all loose needle bearings from the idler shaft hole and throw them away, as they are not needed with the new pump. You will need to reinstall the needles in the drive shaft hole. There are twenty-four (24) needles in each bearing. Coat the needle bearings with grease and place them back in the bearing housings in the drive shaft hole that goes all the way through. If the bearings are "caged" do nothing with them.
5. Remove (2) dowel pins from the pump base.
6. Wipe surface of the base clean, removing old oil, dirt, etc.
7. Replace 00120 O-ring provided in pump kit. **(See Figure #1)**
8. **IMPORTANT:** Place a small amount of grease on the tang of the drive shaft. This will help the tang slide past the shaft seal in the pump base without damaging it. Carefully slide the pump into place.
9. Align (4) through holes with (4) empty screw holes in the pump. **(See Figure #2)**
10. Drop the (4) screws provided in the pump kit into the holes. The screws should be started by hand – no air tools.
11. Torque (4) provided screws to between 140 and 160 inch pounds. **(See Figure #3)**
IMPORTANT: Do not over tighten! Do not tighten any other screws in the pump other than the (4) provided loose in the kit.
12. If you removed the motor, turn the drive shaft with a pair of pliers to ensure it turns freely after you have tightened the screws.
13. Remove the suction tube and screen assembly from the old pump's suction plate and install it in the new suction plate.
14. Slide the pump assembly back into the reservoir collar, making sure that the tank O-ring is properly installed. A pinched or deformed seal may result in leaking. Make sure that the suction tube assembly is pointing to the bottom of the reservoir. Align the reservoir screw holes with the screw holes in the base while sliding them together. You may need to tap on the base with a rubber mallet to get it into the reservoir collar.
15. Replace (6) tank screws and tighten. If you have a plastic reservoir, tighten the band clamp.

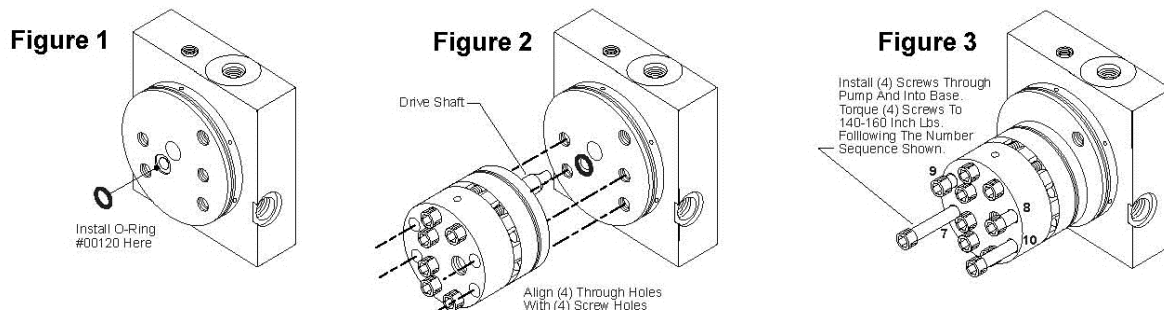

Arctic Equipment Manufacturing Corporation reserves the right under its product improvement policy to change construction or design details and furnish equipment when so altered without reference to illustrations or specifications used.

HANDHELD CONTROL for VEE BLADE

1. Turn the ON/OFF switch on the control to the ON position. The control keypad will glow green, indicating the control is on.

NOTE: The ON/OFF switch can be used as an emergency stop when required.

2. Press the DOWN button for 1.3 seconds to engage the FLOAT mode. The FLOAT indicator light, located in the center of the keypad (logo), will change from green to red. To cancel the FLOAT mode, momentarily press the UP button.

FLOAT mode will automatically cancel after 20 minutes, and the FLOAT indicator light will turn back to green. To restart FLOAT mode, repeat step 2.

3. To achieve the faster straight blade function, it is necessary to tap the "R" key twice, and the keypad light will change from green to blue. To "ESCAPE" back to the Vee plow functions, tap the "R-WING OUT" key and the light will change back to green.

Blade Operation Time Outs

All control functions automatically time out (shut off) after a period of time. This helps reduce wear on the pump motor and prevent unnecessary battery drain. All functions will time out after 6 to 8 seconds.

Automatic Shutdown

After being idle for approx. 22 minutes, the control will automatically turn off and the indicator light located at the center of the keypad (logo) will blink from red to green. To restart the control, turn the control OFF (ON/OFF switch) and then back ON.

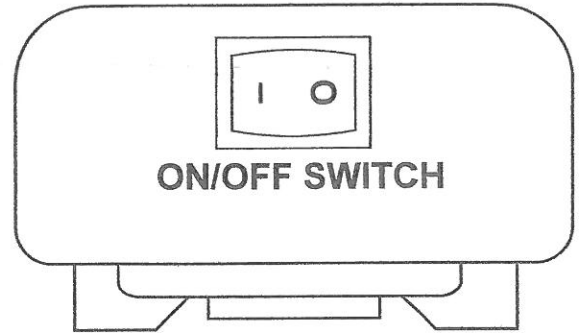

(LOCATED ON TOP OF HANDHELD CONTROL)

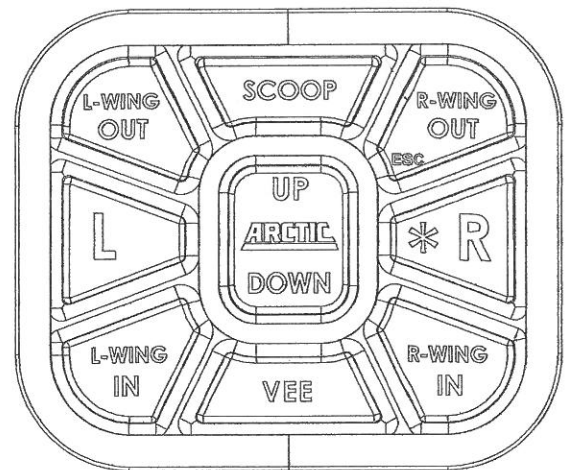

KEYPAD



WARNING

TO PREVENT
ACCIDENTAL ACTIVATION
OF PLOW, TURN PLOW
OFF WHEN NOT IN USE

Troubleshooting flow chart for power unit M3500V

- Motor does not operate.
- Motor operates continuously.
- Snow plow does not raise.
- Snow plow raises up very slow.
- Snow plow will not lower.
- Snow plow leaks down.
- Snow plow angles before going up when up switch is pressed.
- Snow plow when is fully angled going up when angle switch is pressed.
- Snow plow does not go in vee position.
- Snow plow does not go in scoop position.
- Right wing does not extend.
- Right wing does not retract.
- Left wing does not extend.
- Left wing does not retract.
- Snow plow does not hold angle.

WARNING

- Fluid under pressure can pierce the skin and enter the bloodstream resulting in serious injury or death.
- Eye protection and protective clothing must be worn when working on any portion of the snowplow.
- Remove any jewellery (rings, bracelets, watches, necklaces) that could conduct electricity while working with electrical system.
- Lifted blade should be securely propped or immobilized while working on it or any other suspended part so it cannot fall.
- Do not operate blade when anyone is within a 10 foot radius of it.
- Do not use Teflon tape on hydraulic fittings as it can easily jam valves and plug the filters in the system.

Specification:

-Max Amp Draw 230 AMP (AMP draw of motor should be measured at maximum raise or maximum angle when motor is running at relief pressure setting).

Note: Do not operate motor continuously for more than 30 sec

-X-over relief valve setting 3000 psi.

-Note: Quick couplers are an optional item. If unit is not equipped with quick couplers, disregard troubleshooting steps involving them.



Power unit 2012+ - Pump used FP12171-380-SA
- a relief valve setting at 1500 psi



Power unit prior to 2012- Pump used
FP12171-250-SA - a relief valve setting at
2250 psi.

Troubleshooting tips M3500V:

Note: For power unit prior to 2012 relief valve setting is 2250 psi, and for power units 2012+ setting is 1500 psi.

1. Pump shaft can be turned freely (smoothly) using two fingers. If it can't be turned replace pump. Proper pump rotation is clockwise looking from the motor end.
2. Use a screwdriver to check magnetism of solenoid coils. Place screwdriver on the nut securing the coil and have the switch operated. Strong magnetic attraction should be felt.
3. Measure pump pressure at an angle hose (at full angle)(assuming that cross over relief valve setting is 3000 psi, if X-over relief valve setting is less than relief valve setting pressure gage will read lowest reading). The most accurate reading of system pressure is reading pressure on lift cylinder. When testing or making adjustments on the relief valve the system must be "dead headed" (cylinder at full stroke or in a position where cylinder movement is zero).
4. AMP draw of motor should be measured at maximum raise or maximum angle when motor is running.
5. Use volt meter or test light to test for power in a harness or continuity in a switch. A test light is simply a light bulb which has one end connected by a wire to an alligator clip and the other end connected to a metal probe. It is used to check the electrical circuit when the battery is connected to the system. The alligator clip is grounded and the light glows when the probe comes in contact with a "live" electrical component.
6. Do not screw cartridge valves into cavity too fast; use a back and forth motion and have O-rings well lubricated.
7. Clean all parts thoroughly before assembly and lubricate with clean oil.
8. Do not use Teflon tape on hydraulic connections as it can easily jam the valves and plug the filters in the system, use pipe sealant. Never apply pipe sealant at the end of fitting, always 2- 3 threads back.
9. X-over pressure could be set using hand (hydraulic) pump. Example: If you want to set the pressure at x-over XA1 insert hand pump hose in the C1 port together with pressure gage. Loosen the jam nut and turn adjusting screw clockwise a turn or two and watch the gauge; if it goes up, continue to turn the screw until the required setting is reached. Retighten the jam nut. To set X-overs XA2, XD1 and XD2 repeat the same steps as setting XA1.
- 10 .To adjust relief valve:
 - a. Loosen jam nut counter-clockwise.
 - b. Turn screw clockwise to increase pressure or turn screw counter-clockwise to decrease pressure.
 - c. Tighten jam nut clockwise to 50in.lb. torque.
 - d. Check system pressure after jam nut is tight. Readjust pressure if screw is moved during tightening of jam nut.

MOTOR DOES NOT OPERATE M3500V

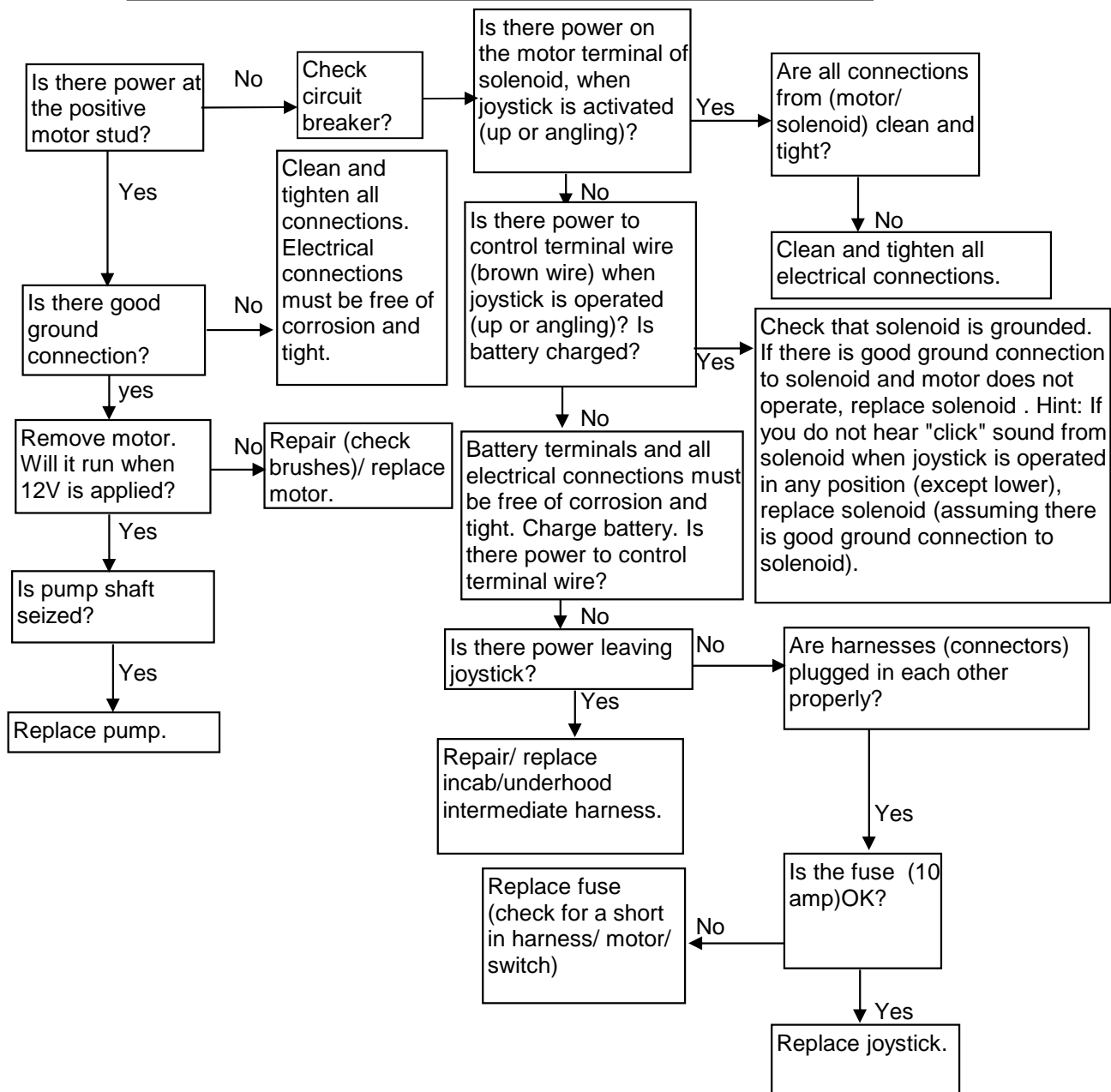

MOTOR OPERATES CONTINUOUSLY M3500V

If motor operates continuously, change solenoid.

SNOW PLOW DOES NOT RAISE M3500V

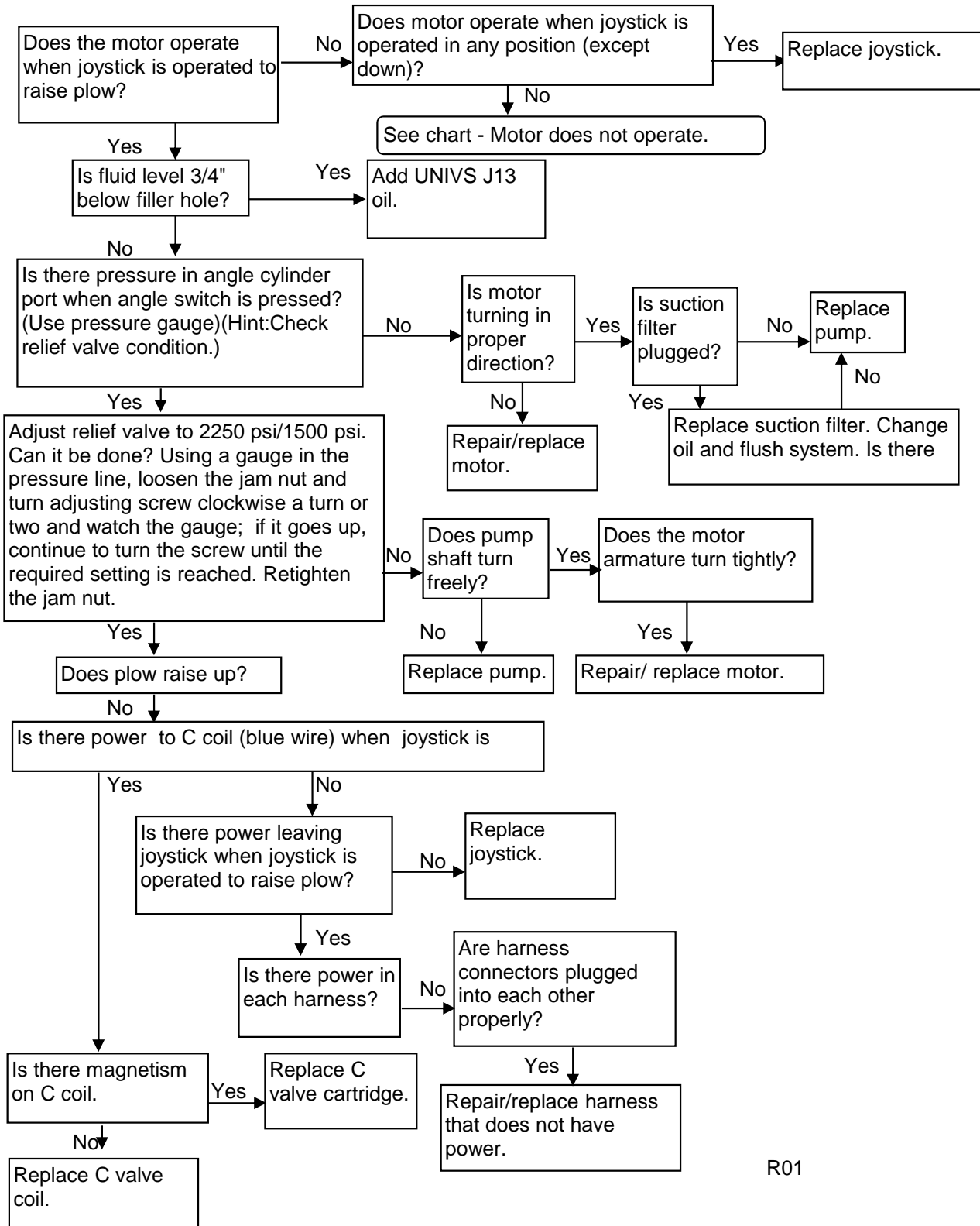

SNOW PLOW RAISE VERY SLOW M3500V

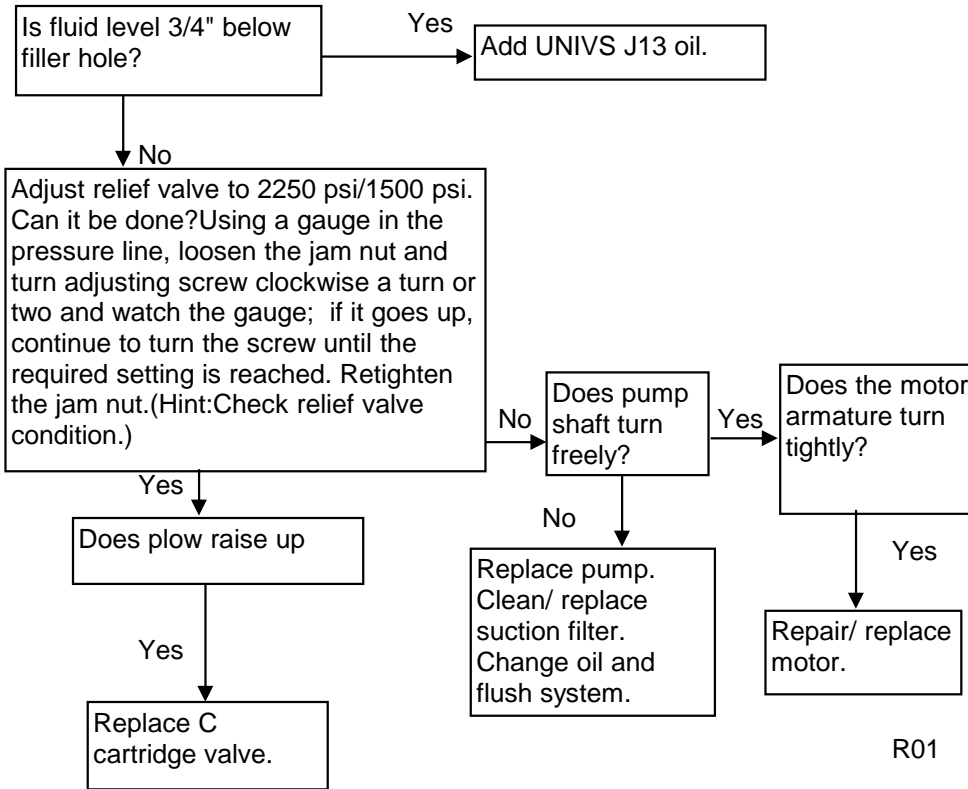

SNOW PLOW WILL NOT LOWER M3500V

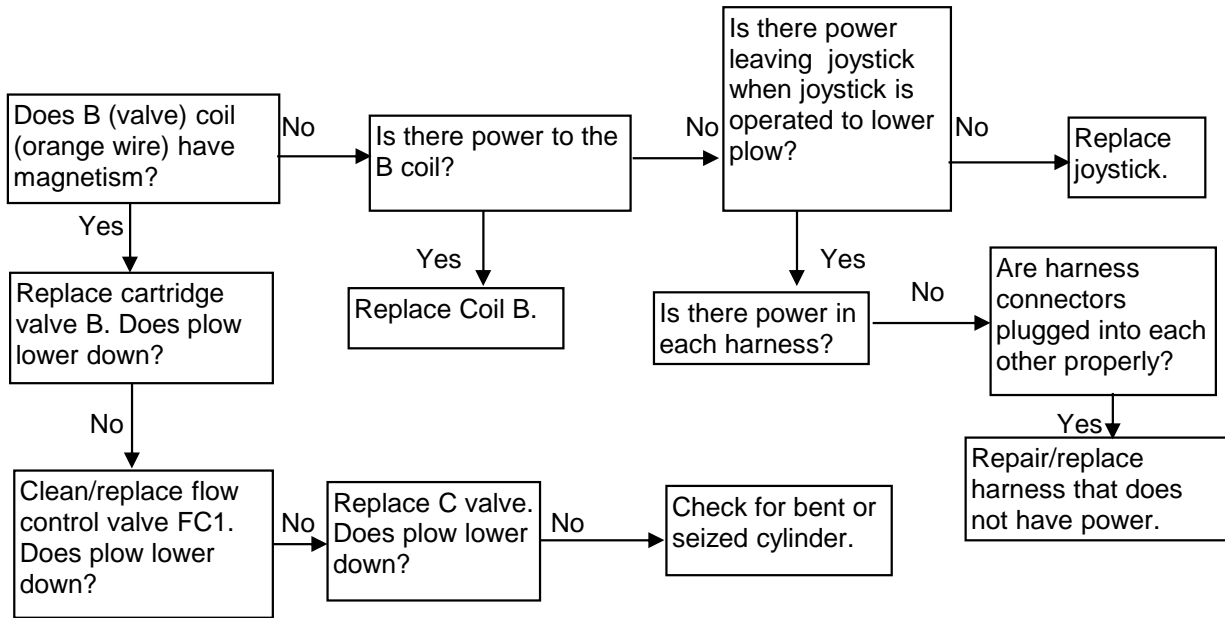

SNOW PLOW LEAKS DOWN M3500V

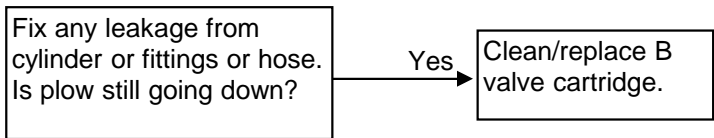

SNOW PLOW ANGLES BEFORE IT GOES UP WHEN JOYSTICK IS OPERATED TO RAISE PLOW M3500V

If snow plow angles before it goes up change following cartridge:
A2 if right wing retracts, A1 if right wing extends, D2 if left wing retracts, D1 if left wing extends

SNOW PLOW WHEN IS ANGLED IT GOES UP WHEN JOYSTICK IS OPERATED TO ANGLE PLOW M3500V

Change C Valve cartridge.

SNOW PLOW DOES NOT ANGLE TO LEFT SIDE M3500V

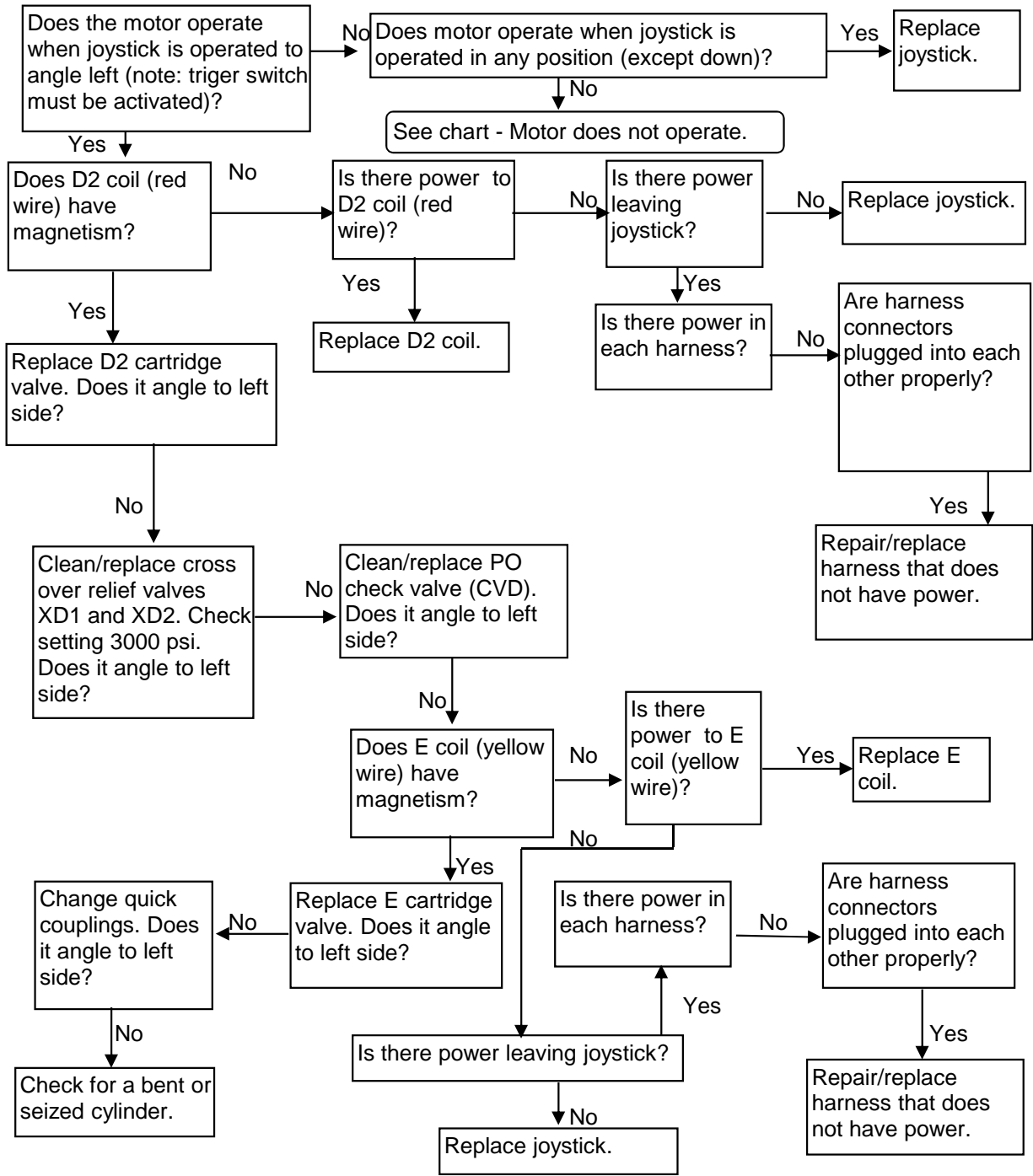

Note: Before start troubleshooting check that plow moves up and down. If plow does not move up and down see "plow does not raise".

PLOW DOES NOT GO IN VEE POSITION M3500V 1 of 2

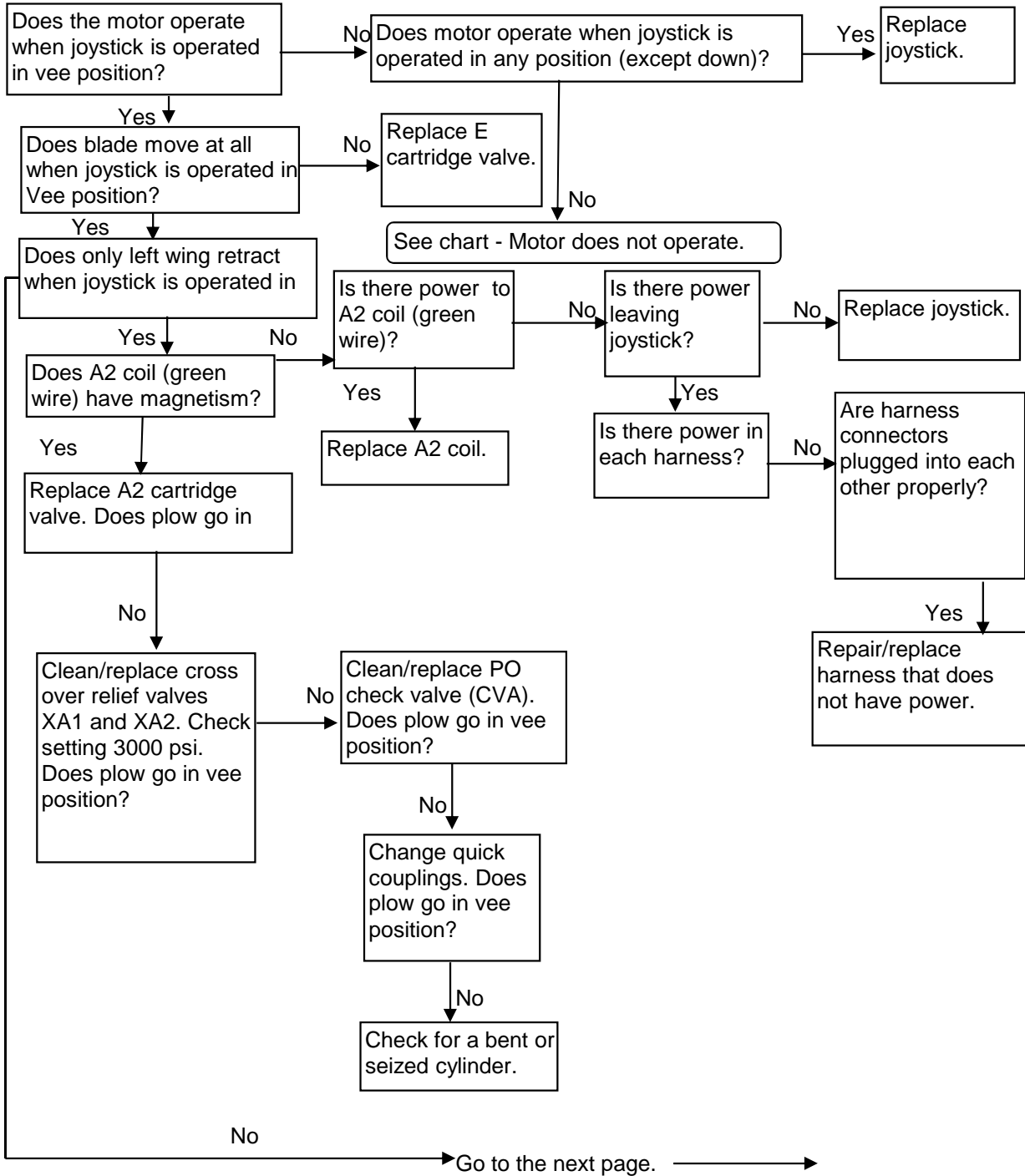

Note: Before start troubleshooting check that plow moves up and down. If plow does not move up and down see "plow does not raise".

PLOW DOES NOT GO IN VEE POSITION M3500V 2 of 2

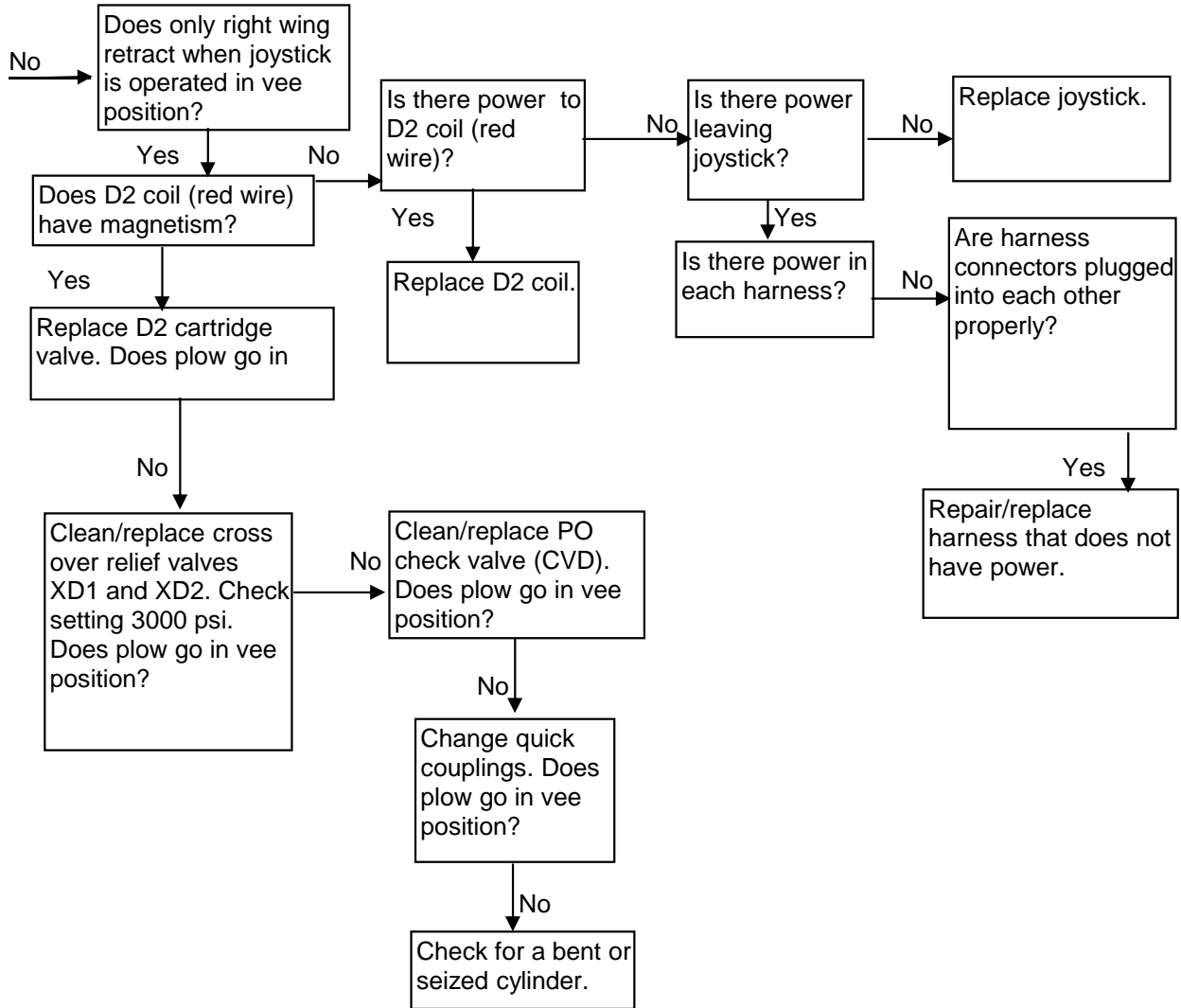

Note: Before start troubleshooting check that plow moves up and down. If plow does not move up and down see "plow does not raise".

PLOW DOES NOT GO IN SCOOP POSITION M3500V 1 of 2

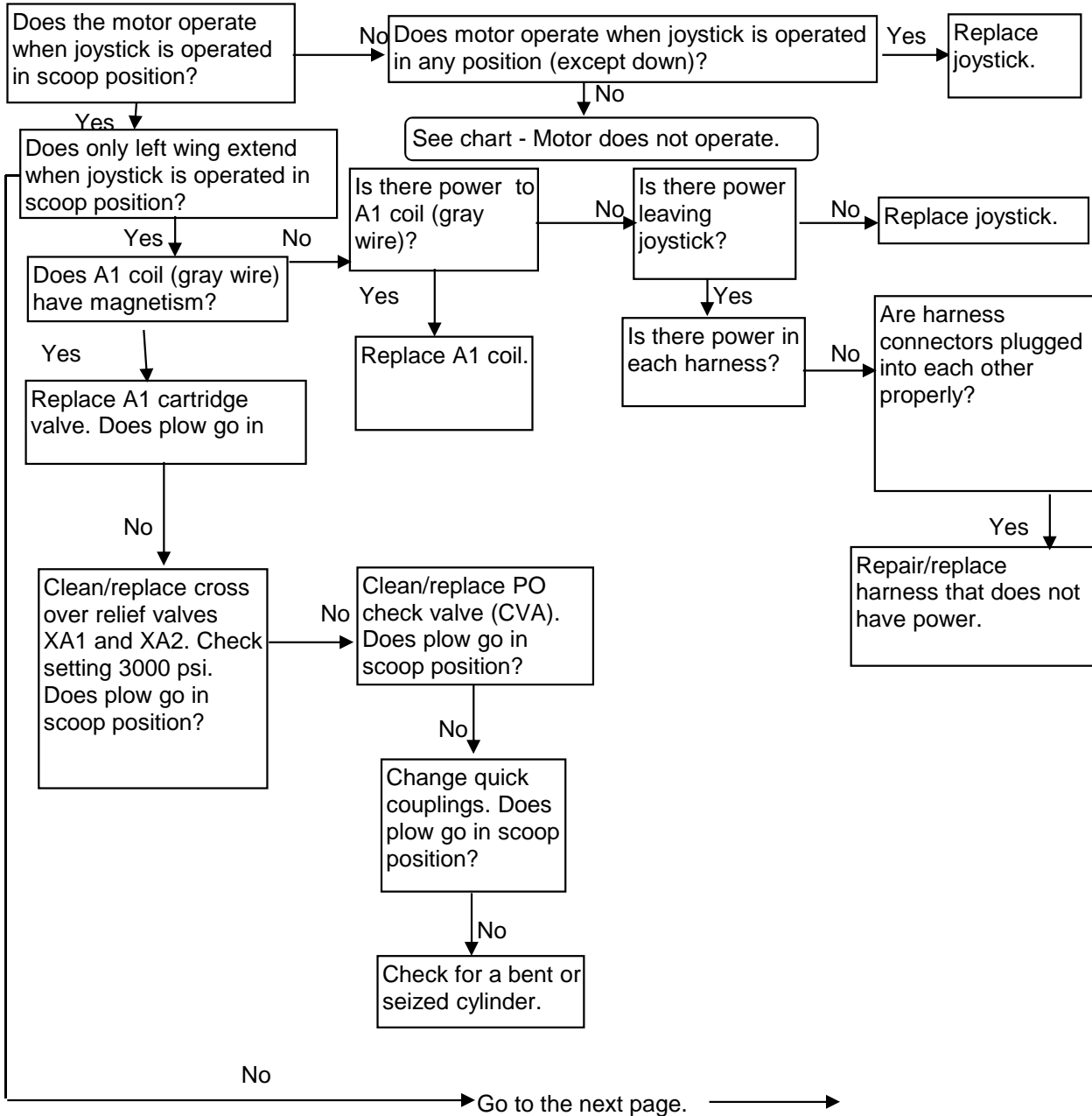

Note: Before start troubleshooting check that plow moves up and down. If plow does not move up and down see "plow does not raise".

PLOW DOES NOT GO IN SCOOP POSITION M3500V 2 of 2

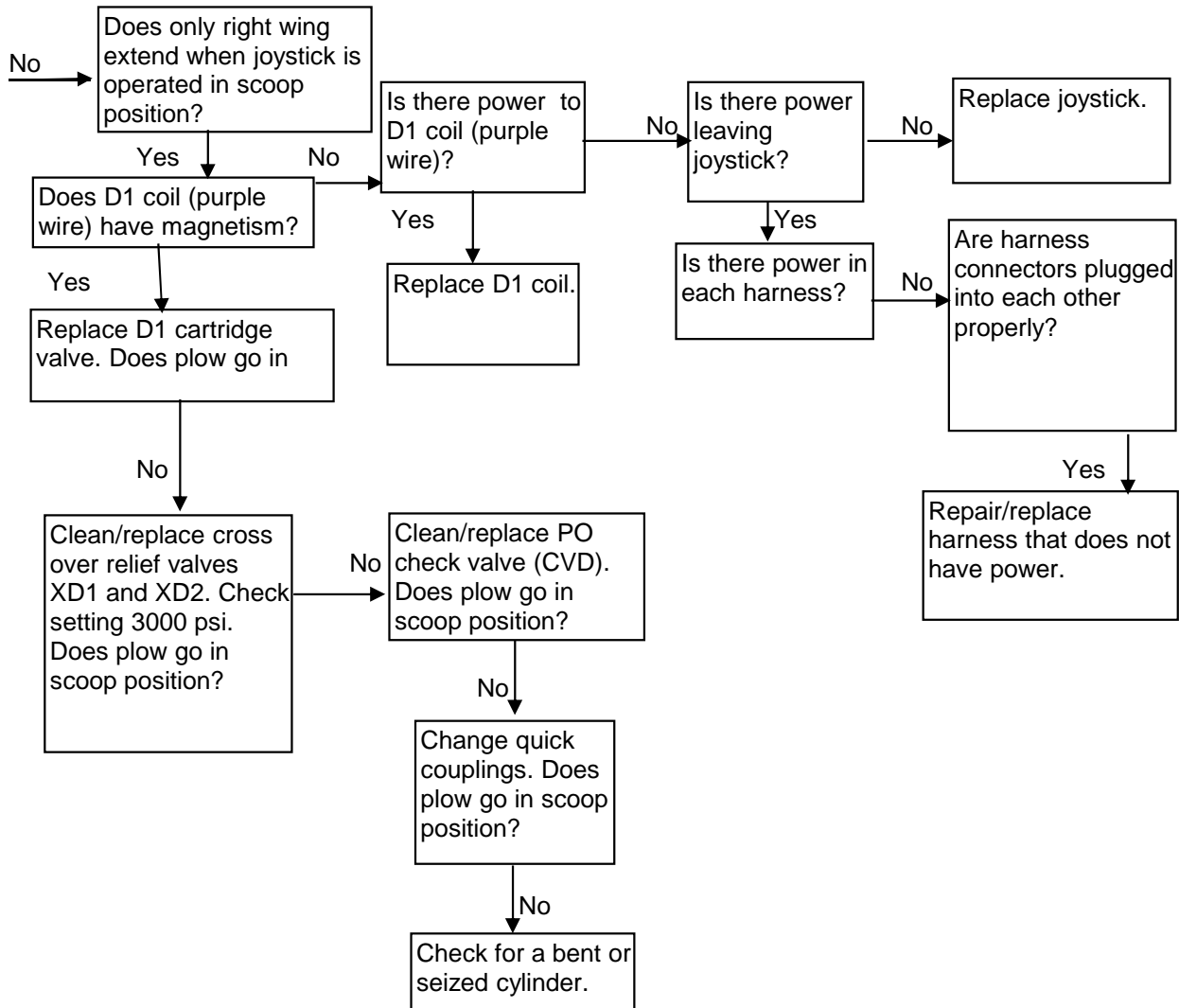

Note: Before start troubleshooting check that plow moves up and down. If plow does not move up and down see "plow does not raise".

RIGHT WING DOES NOT EXTEND M3500V

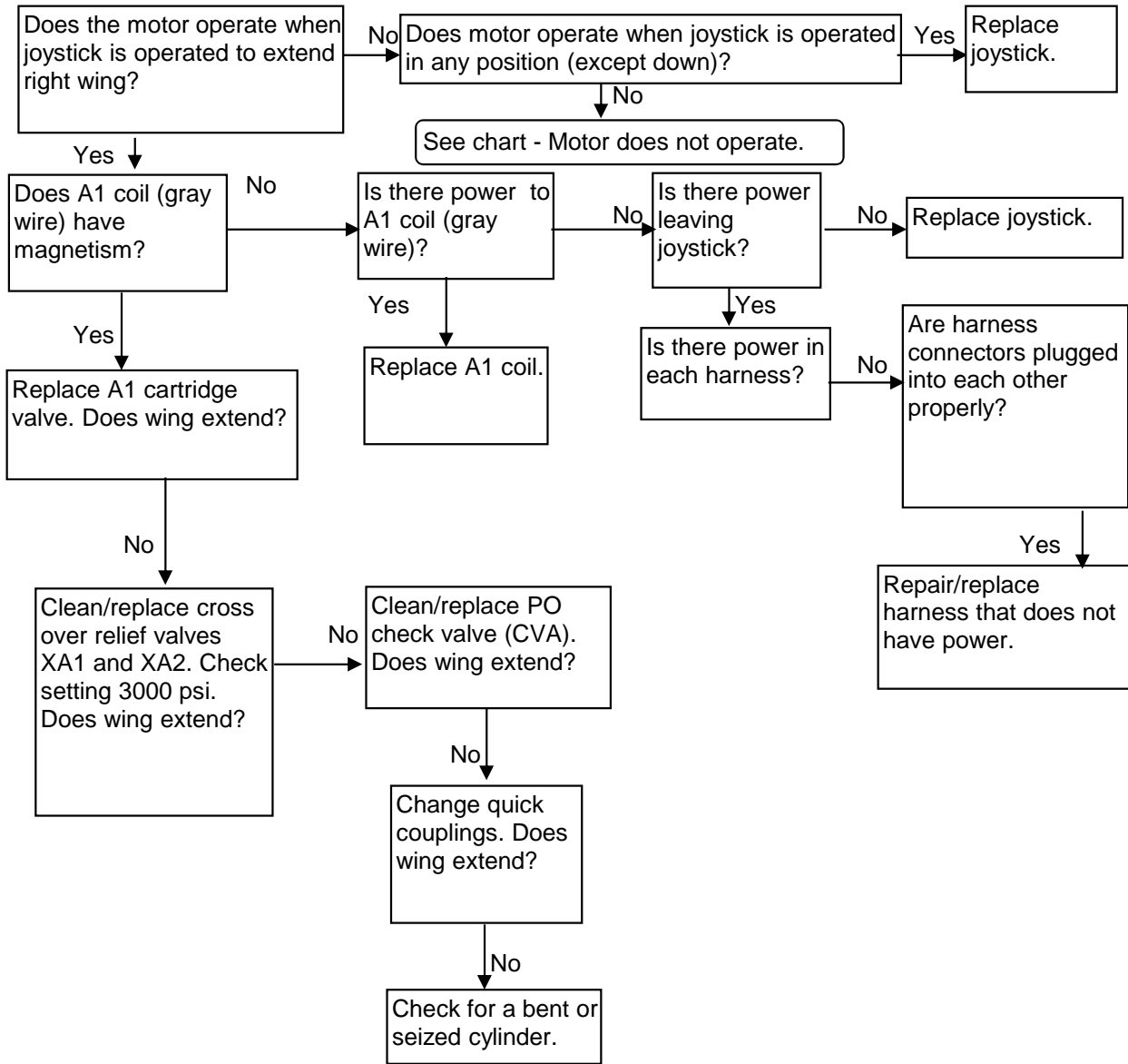

Note: Before start troubleshooting check that plow moves up and down. If plow does not move up and down see "plow does not raise".

RIGHT WING DOES NOT RETRACT M3500V

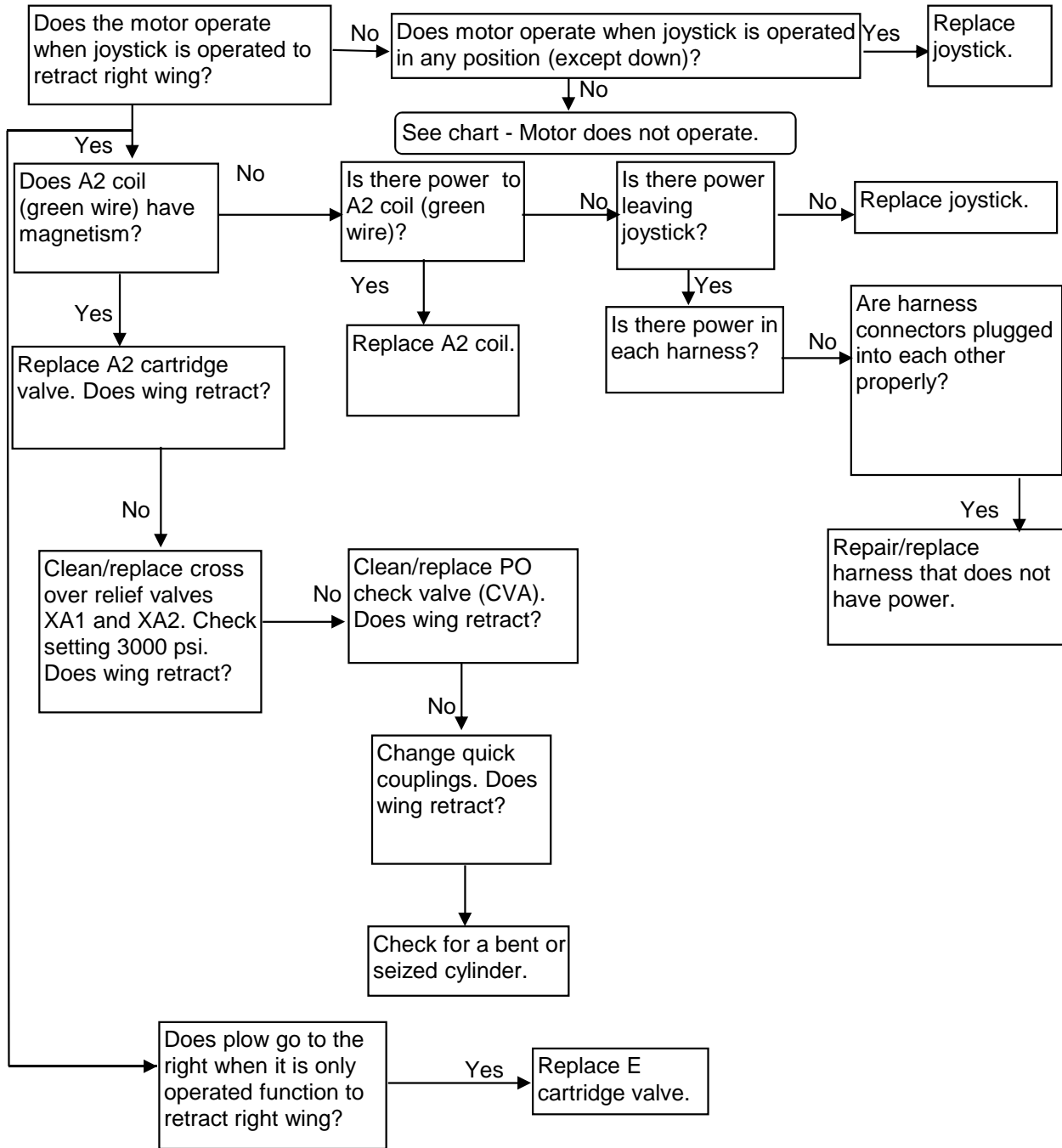

Note: Before start troubleshooting check that plow moves up and down. If plow does not move up and down see "plow does not raise".

LEFT WING DOES NOT EXTEND M3500V

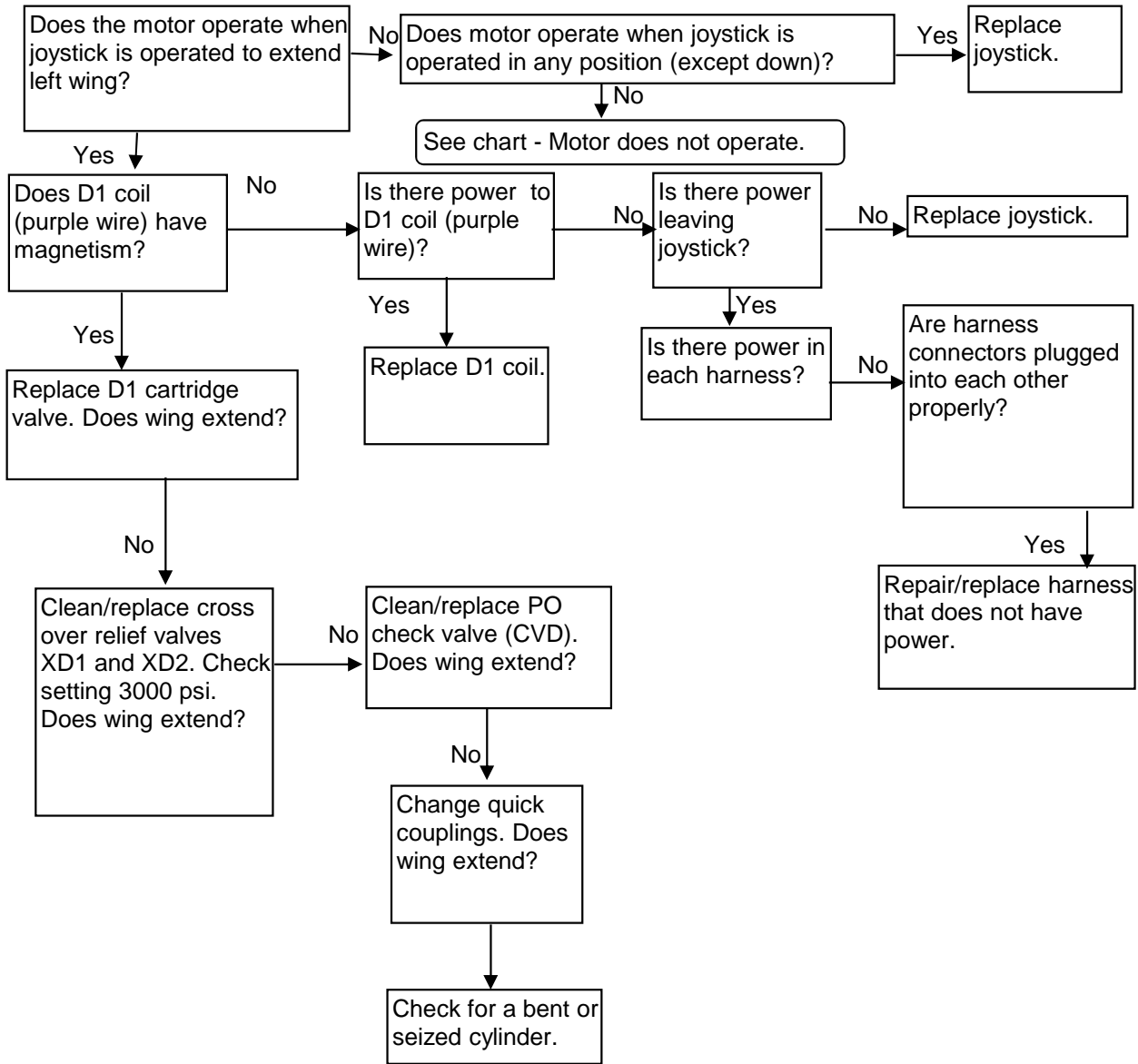

Note: Before start troubleshooting check that plow moves up and down. If plow does not move up and down see "plow does not raise".

LEFT WING DOES NOT RETRACT M3500V

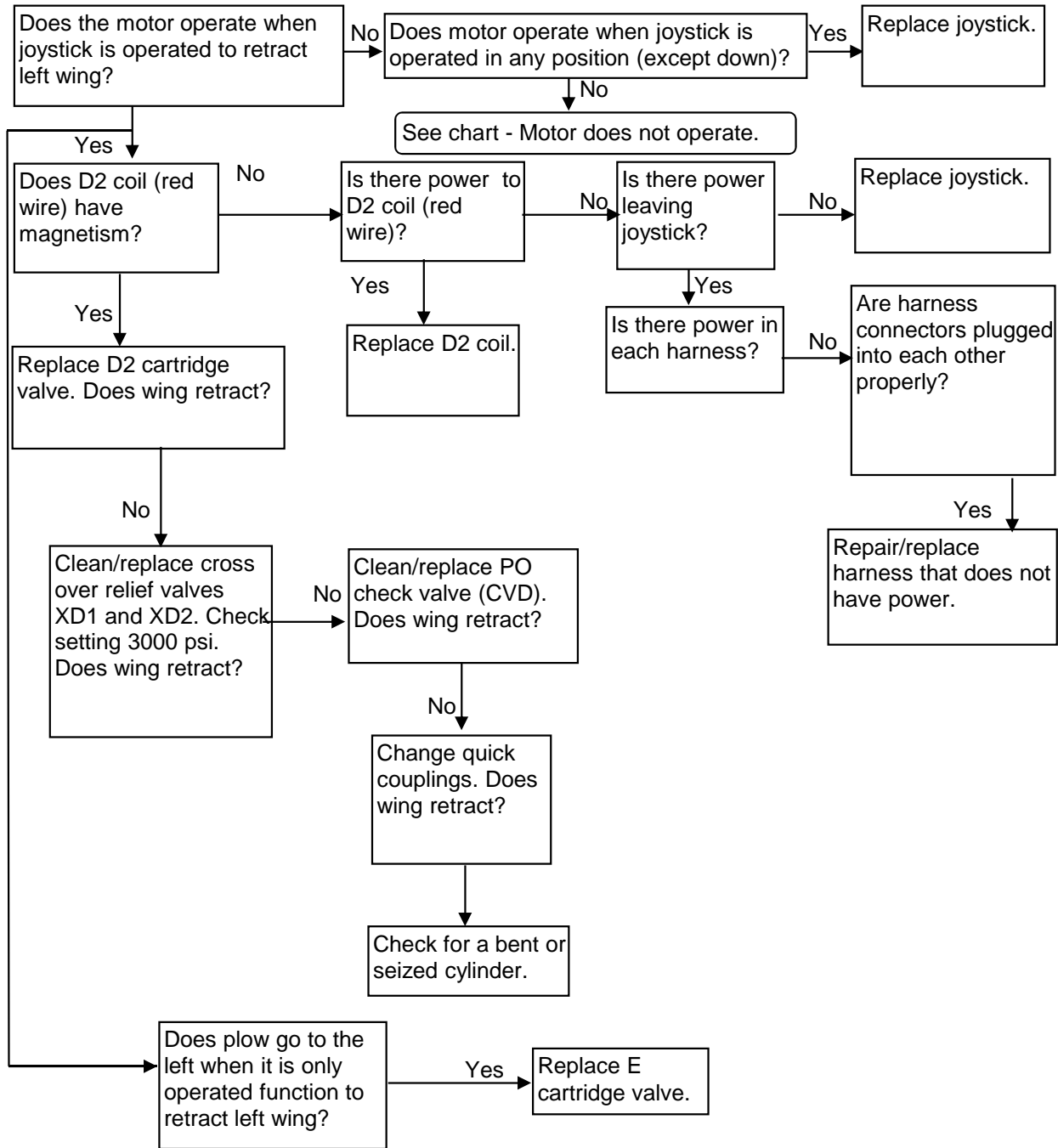

Note: Before start troubleshooting check that plow moves up and down. If plow does not move up and down see "plow does not raise".

PLOW DOES NOT HOLD ANGLE M3500V

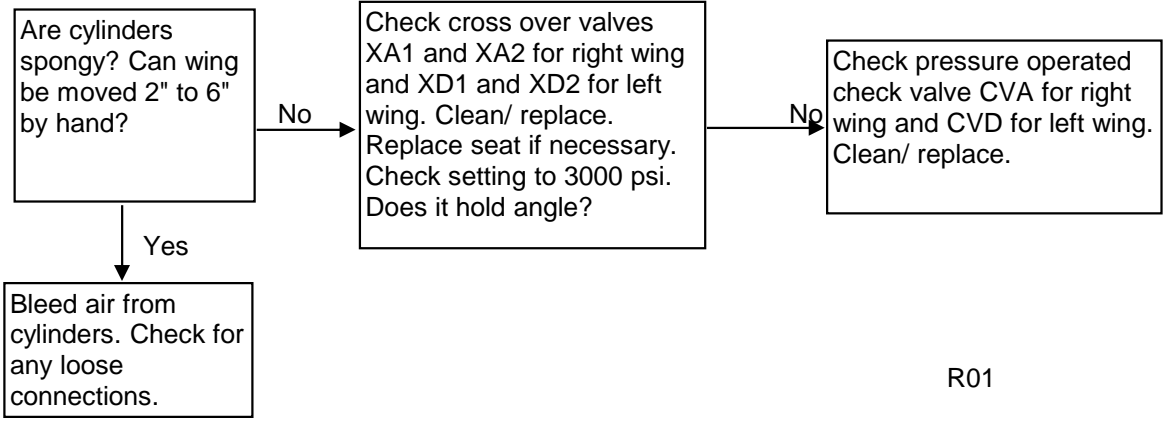

R01

Hydraulic Jack Installation

(only with QLIV attachment)

53216-M-HJ

(To be used only with the one piece harness)

 Warning

- Top of battery needs to be protected. If positive side of battery is accidentally grounded person could be burnt or wiring system can be damaged, or battery gasses could explode causing injuries.
- Disconnect cable from negative battery terminal before starting installation.
- Always wear eye protection and protective clothing when working around hydraulic systems.
- Remove jewelry and objects that might conduct electricity while working on power units.
- Fluid under pressure can pierce the skin and enter the bloodstream causing death or serious injury.
- Hydraulic hoses and electrical cables (harnesses) must be tied and routed safely to avoid any damage and pinching (away from hot places, sharp objects etc.).



53216-M-HJ Hydraulic Jack Kit			
	Item	Description	Quantity
1	53174-M	Lock bracket	1
2	53177-M	Lock Handle	1
3	51002-M	1/4"X18" Hose Assembly	2
3a	51904-M	1/4"X 29" Hose Assembly	
4	53178-M	Top Plate Lock	1
5	53179-M	Spring Bracket	1
6	53170-M-BB	Bolt Bag	1
7	52612-B-GA	Lift Channel	1
8	53568-A	Bottom Jack Bracket	1
9	HH-00972-089	1/2-20x1.1/4 HHCS	3
10	50999-B	Blade Guide	2
11	HH-00340-003	1/2" NC Hug Nut	1
12	53181-B	Pin	2
13	53180-M	Lock Spacer	1
14	53182-N	Spring	1
15	53573-M	Switch Jack Kit (include wiring, switch, relay)	1
15a	53573-01-N	Switch Only	1
15b	53573-02-N	Relay Only	1
16	HH-00972-155	3/4-16x4 HHCS	2
17	53567-N	Top Jack Bracket	1
18	53566-N	Hydraulic Jack 2"x 12"	1
19	HH-00540-004	1/2-20 Lock nut	5
20	HH-00972-139	5/8-18x4.1/2 HHCS	1
21	HH-00540-002	5/8-18 Nylon Insert Lock	1
22	HH-00293-028	5/16-18x1.25 HHCS	2
23	HH-00341-003	5/16 Flatwasher	4
24	HH-00457-007	5/16 Lockwasher	2
25	HH-00293-094	1/2-13x2.1/2 HHCS	1
26	53526-A	Jack Foot Assembly	1
27	FPN0546	Self-Tapping Screw, 10-24	4
28	FPN0339	Manifold Valve Cover	1
29	HH-00790-002	90 Deg Swivel Elbow	7
30	53576-N	Manifold Jack (include all valves)	1
30a	FP7249-D	Valve, #8, 3W / 2P, valve assembly	2
30b	FP18835-D	Coil only, 12VDC, 3W/2P	1
30c	FP0679-D	Valve cartridge only, 3W / 2P	1

53216-M-HJ Hydraulic Jack Kit			
	Item	Description	Quantity
30d	FP7217	Check Valve	2
30e	FP7218	Piston	1
30f	FP7527	Relief valve kit	1
31	HH-00293-051	3/8-16x1.1/2 HHCS	1
32	FP1414	Fitting	1
33	HH-00271-004	7/16" Flat Washer	

Installation of Hydraulic Jack



- Install Bottom Jack Bracket (8) using 1/2" x 1 1/4" bolt and nut (9) & (19) (only from one side).
- Install Top Bracket (17) using two 1/2" x 1 1/4" bolts and nut (9) & (19).



- Secure a cylinder using 5/8" x 4.5" bolt and lock nut (20)(21).
- Install a cylinder foot (26) using 1/2" x 2 1/4" bolt and nut (25)(19) through the bottom hole (the top hole is used for higher trucks).
- Install a manifold on the side of lift frame using two flat washers under each bolt (washer are located between manifold and lift frame). Install 5/16" bolt, lock washer and flat washer (22)(23)(24).

V plow installation M3500V power unit



Manifold installation – front view.

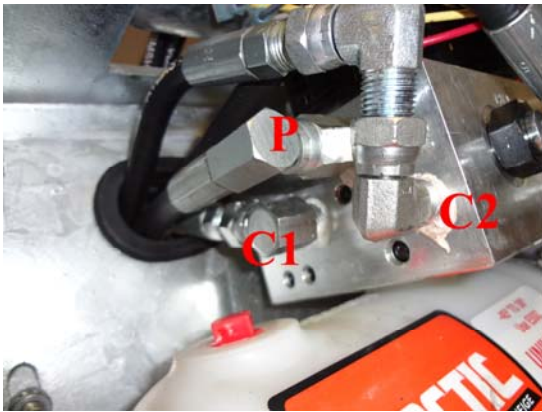

V plow power unit (P and T hoses installation)

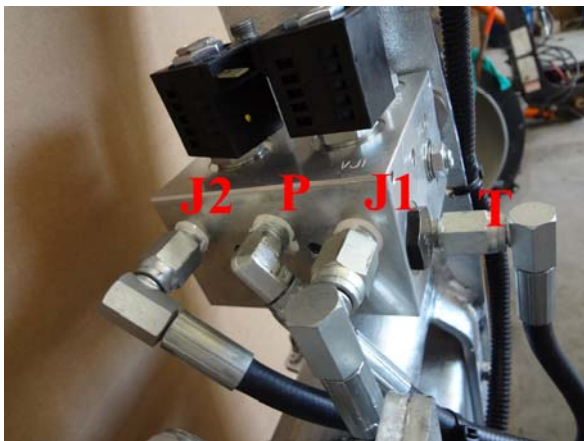

Manifold hose installation.



Jack

hose installation 18\"/>

Wing plow installation

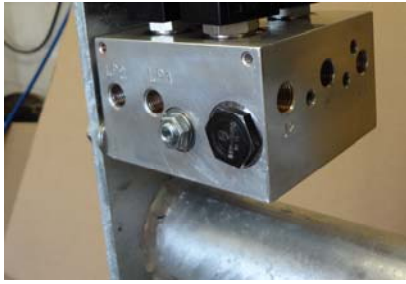

Manifold installation – front view.



Wing plow power unit (P and T hoses installation 29")



Manifold hose installation.



Jack hose installation 18".

Installation of Jack Harness



Secure the relay under mounting plate box and install switch with 7/16" flat washer (33).

Arctic Equipment Manufacturing Corporation reserves the right under its product improvement policy to change construction or design details and furnish equipment when so altered without reference to illustrations or specifications used.

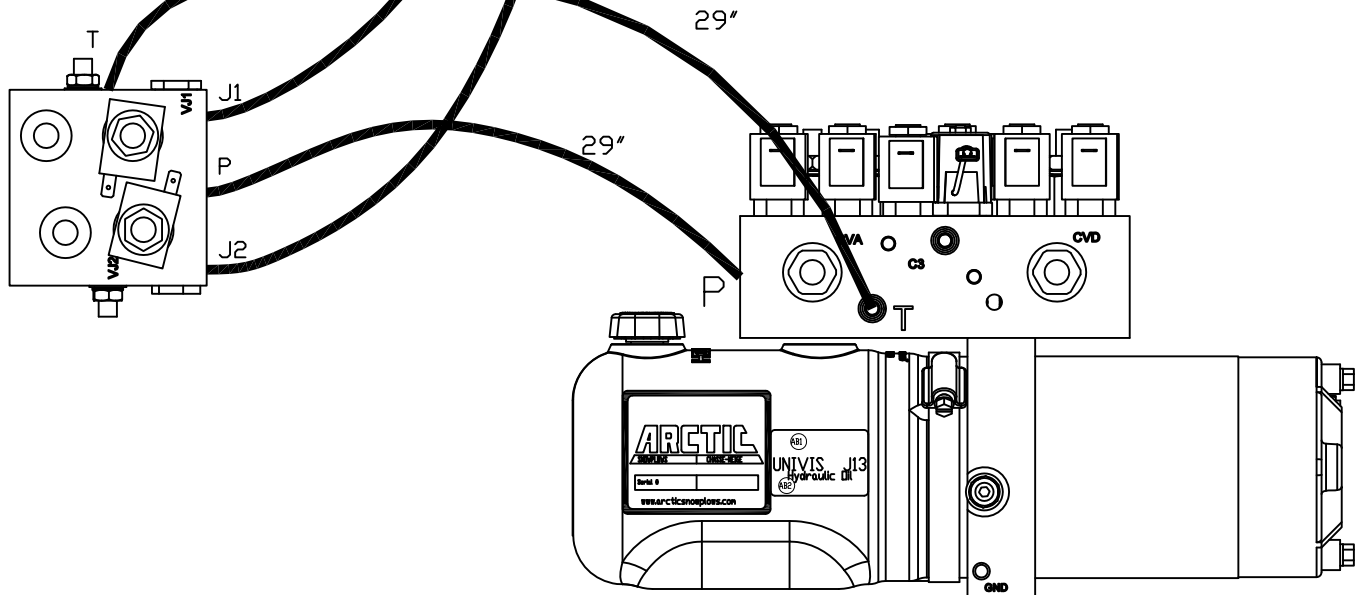
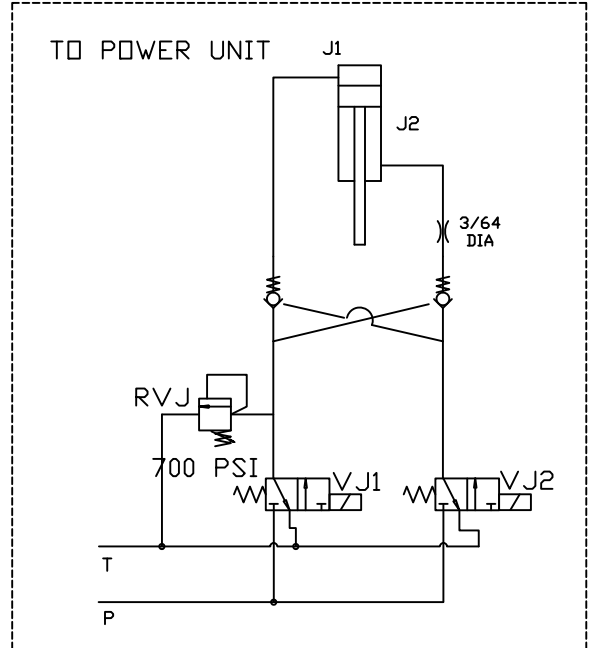
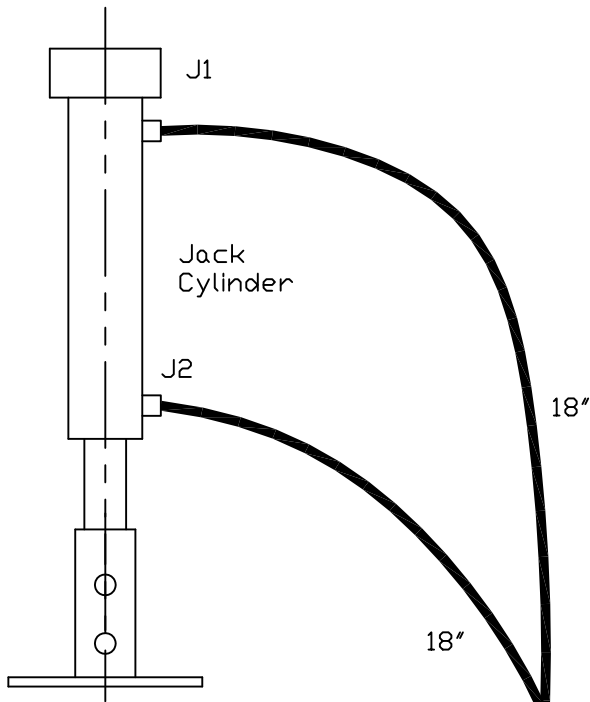

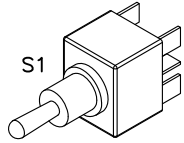

RELAY (JACK SWITCH)

JACK SWITCH		
PIN #	COLOR	AWG
85	BROWN (PUMP)	N/A
86	BLACK (GROUND)	N/A
30	EXISTING UP	N/A
87	BROWN (PUMP)	N/A
87a	PLOW UP (PINK/BLACK)	N/A

K1

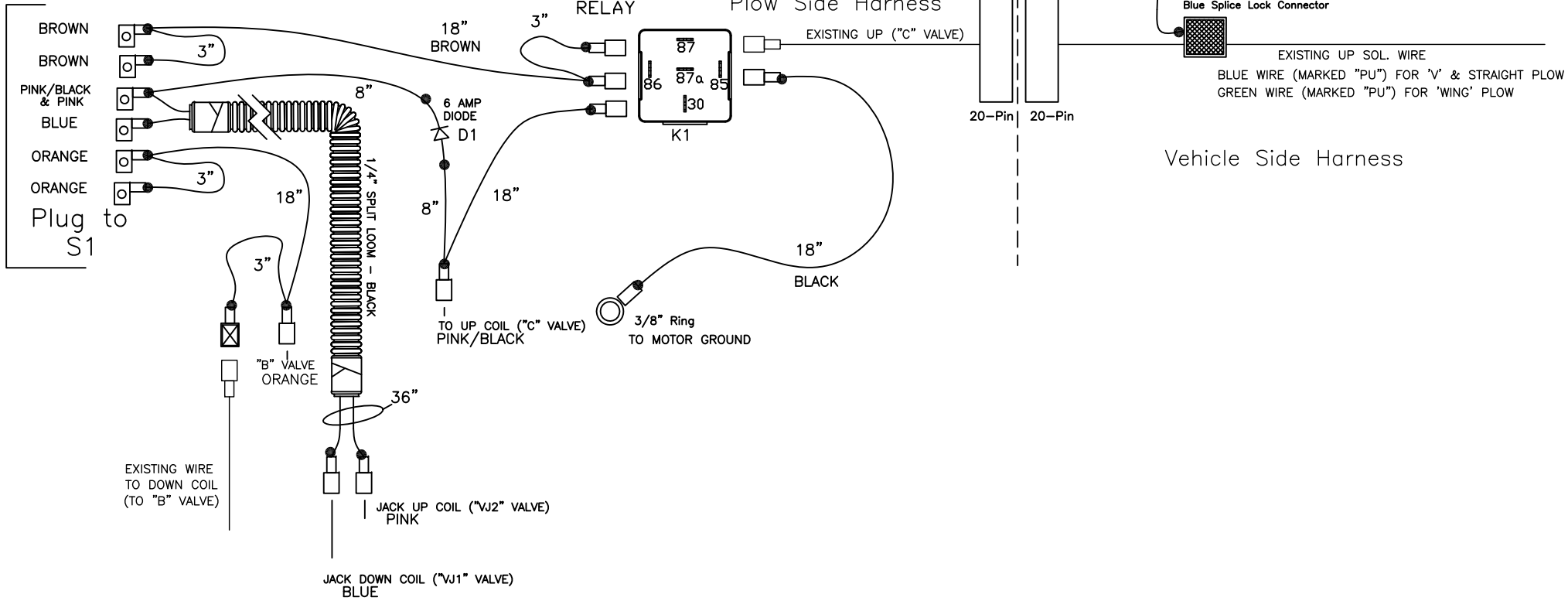
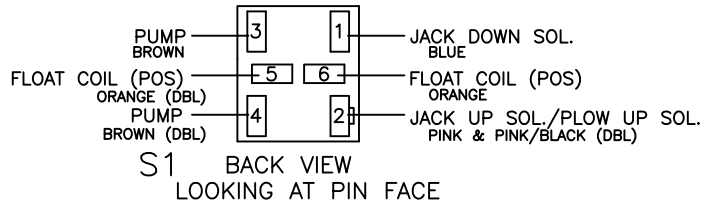

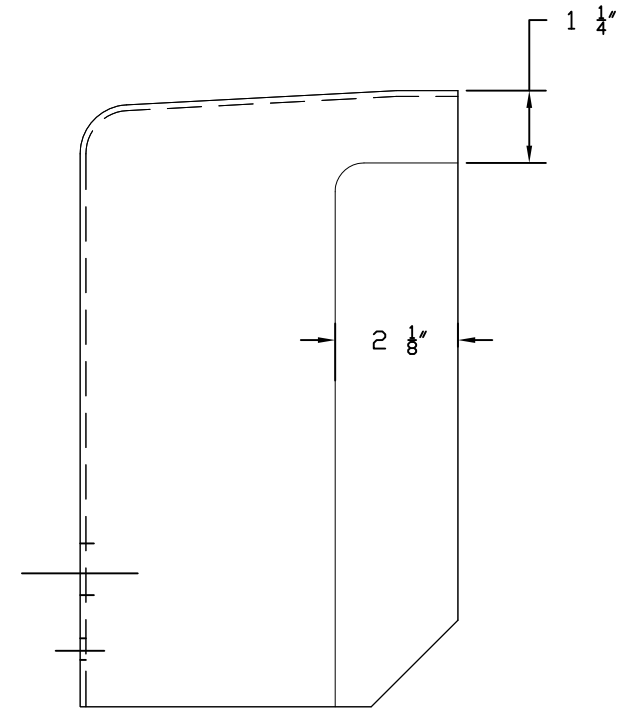

VIEW A-A
(modify only
one side)



